

# SPRAY NOZZLES, FABRICATIONS, AND ENGINEERED SYSTEMS



THE  
**SPRAY NOZZLE**  
PEOPLE



01273 400092 | [info@spray-nozzle.co.uk](mailto:info@spray-nozzle.co.uk) | [www.spray-nozzle.co.uk](http://www.spray-nozzle.co.uk)

# Table of Contents



**W**ith thousands of different spray nozzles available in hundreds of different materials, it's often hard to know where to start. We've incorporated a number of unique charts and other aids into this catalog to simplify your selection process.

## Nozzle Selection Guide

There are many ways to select a nozzle. Which way is right for you?

### → BY SPRAY PATTERN....PP. 2-4

**Do you know the spray pattern, but not the type of nozzle?.....see pages 2-4**

This section introduces you to the types of spray patterns and the spray nozzles available in each.

### → BY APPLICATION....PP. 5-11

**Want to see what nozzles excel at your specific application?.....see pages 5-11**

An alphabetical list of common applications and the nozzles that are used most frequently for each.

Still not sure? Don't have time to look? **Call us.** BETE Customer Service Representatives and Applications Engineers will listen to your problem and guide you to the nozzle you need. Let our expertise save you time and keep your process running at peak efficiency.

**1-800-235-0049  
1-413-772-0846**



**[www.bete.com](http://www.bete.com)**

Visit our website to search nozzles by spray pattern, nozzle type, material, and more. Review case studies by industry to learn why BETE solutions lead to our customers' success.



**Watch Spray Pattern & Demo Videos**  
[www.youtube.com/c/BETESprayNozzles](http://www.youtube.com/c/BETESprayNozzles)

**Follow BETE**

**/company/betespraynozzles/**

**@BETESprayNozzles**

**@BETE\_tweets**

**@bete\_spray**

*Payment with Visa,  
Mastercard and American Express  
accepted.*



## Alphabetical Nozzle Index

AFF	113
BJ	62, 63
BJH	64
CLUMP	111
CW	Full Cone: 36; Hollow Cone: 52
EZ	Full Cone: 38; Hollow Cone: 54, 55; Fan: 72, 73
FF	70, 71
FINZ	125
HydroClaw	109
HydroPulse	24-27
HydroWhirl Orbitor (HWO)	107
HydroWhirl Orbitor 100	108
HydroWhirl Poseidon (HWP)	106
HydroWhirl S (HWS)	105
IS	122
L	79
LEM	112
LP	123
MaxiPass (MP)	34, 35
MPL	33
MicroWhirl (MW)	76
N	114
NC	42, 43
NCFL	46
NCJ	57
NCK	45
NCS	44
NF	67
NFD	68
NFH	65
NFS	69
NFV	66
P	78
PJ	77
PSR	124
SAM	100, 101
SC	40, 41
SF	Full Cone: 39; Hollow Cone: 56; Fan: 74
Swivel Joint (SJ)	126
SpiralAir (SA)	102, 103
SPN	75
SS	81
ST	30
STXP	31
TC	47
TDL	120
TF	Full Cone: 28; Hollow Cone: 53
TF29-180	115
TFXP	29
TH	58, 59
THW	60, 61
TurboMix (TM)	121
TW	110
Twist & Dry (TD)	116-120
UltiMist (UM)	80
WL	32
WT	48, 49
WTX	50, 51
WTZ	37
XA	82-99

Nozzle Selection Guide	1-12
Alphabetical Nozzle Index	1
Nozzles by Spray Pattern	2-4
Nozzle by Application	5-11

About BETE	13-15
------------	-------

Spray Lances & Fabrications	16-17
-----------------------------	-------

Spray Engineering & Systems	18-23
-----------------------------	-------

### Nozzles - Spray Pattern Types

Automatic Nozzles	24-27
-------------------	-------

Full Cone	28-47
-----------	-------

Hollow Cone	48-61
-------------	-------

Fan	62-75
-----	-------

Misting	76-81
---------	-------

Air Atomizing	82-103
---------------	--------

Tank Washing	104-112
--------------	---------

Special Purpose & Accessories	127
-------------------------------	-----

### Technical Information

Materials	12
Engineering Data	128-136
Conversion Data	Inside Back Cover

**Innovation is a BETE hallmark  
and we are proud that  
over 60% of the nozzles we ship  
have been customized  
to meet your needs.**

**If you don't see your nozzle listed,  
please call BETE.**

**Special flow rates and angles are  
available for most nozzle series.**



# Nozzles by Spray Pattern

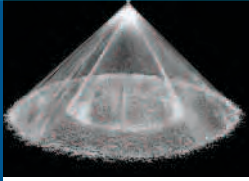

## Full Cone Nozzles

The most frequently used nozzle type in industry is the full cone nozzle. The spray emits from the nozzle in a conical shape with the liquid dispersed over the interior of the cone. When the spray intersects with a surface, a circle of spray is formed with liquid present throughout. The full cone pattern from a spiral nozzle consists of several concentric hollow cones that combine to produce a full cone effect with a smaller droplet size.

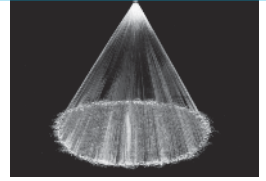

### TF

The standard spiral line, available in a wide range of flows, angles, and materials. 1/8" - 4" p. 28



### TFXP

Same as the TF plus maximum free passage. 3/8" - 4" p. 29



### ST

A Cobalt Alloy tip and 316 stainless connection for spraying abrasive liquids. 1/4" - 4" p. 30



### STXP

Same as the ST with extra rugged construction plus maximum free passage. 3/8" - 4" p. 31



### WL

Low flow rate, full cone nozzles. 1/8" - 1" p. 32



### MPL

Low flow, maximum free passage. Unique, S-shaped internal vanes allow free passage of particles. 1/8" and 1/4" p. 33



### MaxiPass

Patented MaxiPass "S"-shaped vanes for superior distribution and largest free passage. 3/8" - 4" pp. 34, 35



### CW

Low flow rate full or hollow cone, 3-piece construction with optional strainer and cover. 1/8" - 3/8" p. 36



### WTZ

Tangential full cone nozzle with 3-piece construction. 1/4" - 1/2" p. 37



### EZ

Quick connection system, ramped engagement for automatic alignment. 1/8" - 1/2" p. 38



### SF

Snap release nozzle system features clamp-on adapters for easy installation. 1" - 2" p. 39



### SC

Metal full cone nozzles available in a wide range of alloys. 3/4" - 6" pp. 40, 41



### NC

Complete line of full cone nozzles available in a variety of plastic materials. 3/4" - 6" pp. 42, 43



### NCS

"Stubbies"; short NC-type nozzles for use where space is at a premium. 1" - 4" p. 44



### NCK

Narrow spray angle injector. 3/4" - 6" p. 45



### NCFL

Large plastic nozzles with high flow rates for applications where flanged connections are required. 4" - 12" p. 46



### TC

High capacity full cone metal nozzles. 6" - 12" p. 47

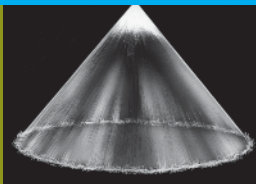

## Hollow Cone Nozzles

Used less frequently than full cone nozzles, hollow cone nozzles produce a thin ring of liquid. The spray emits from the nozzle in a conical shape with the liquid only at the periphery of the cone. When the spray intersects with a surface, a ring of spray is formed with a hollow center.

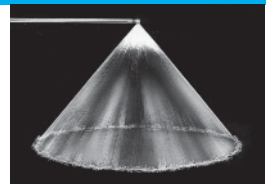

### WT

Tangential hollow cone nozzle with 2-piece construction. 1/8" - 3/4" pp. 48, 49



### WTX

Similar to WT, with design features for extended life. 1/8" - 3/4" pp. 50, 51



### CW

Low flow rate full or hollow cone, 3-piece construction with optional strainer and cover. 1/8" - 3/8" p. 52



### TF

The standard spiral line, available in a wide range of flows, angles, and materials. 1/8" - 4" p. 53



### EZ

Quick connection system, ramped engagement for automatic alignment. 1/8" - 1/2" pp. 54, 55



### SF

Snap release nozzle system features clamp-on adapters for easy installation. 1" - 2" p. 56



### NCJ

Narrow spray angle injector. 3/4" - 6" p. 57



### TH

Larger one-piece tangential hollow cone nozzle. 1" - 3" pp. 58, 59



### THW

Same as TH, with wide spray pattern. 1" - 3" pp. 60, 61





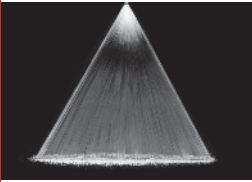

### Fan Nozzles

These nozzles produce a thin, flat sheet of liquid that expands outward from the nozzle. A thin line of liquid is produced when the spray intersects a surface. As the liquid is concentrated into a smaller net area, the impact force from fan nozzles is greater than from full or hollow cone nozzles.

#### BJ

Low flow nozzle with interchangeable tips; fan spray. 1/8" - 3/8"



pp. 62, 63

#### BJH

Interchangeable tips, strainer. Male and female tips. Can be used with HydroPulse. 1/8" - 1/2"



pp. 64

#### NFV

Fan nozzle with integral strainer option. 1/8" or 1/4"



p. 66

#### NF

Standard fan nozzle featuring high impact fan or straight jet spray. 1/8" - 2"



p. 67

#### NFD

Flat fan nozzle with self-aligning dovetail connection and interchangeable tips. 1/4" - 1 1/4"



p. 68

#### NFH

Tungsten carbide orifice inserts for maximum wear resistance and service life. 1/4"



p. 65

#### NFS

Stubby fan nozzle for use where space is at a premium. 1/4" - 2"



p. 69

#### FF

Deflector-style; extra-wide angle flat fan spray. 1/8" - 1"



pp. 70, 71

#### EZ

Quick connection system, ramped engagement for automatic alignment. 1/8" - 1/2"



pp. 72, 73

#### SF

Snap release nozzle system features clamp-on adapters for easy installation. 1" - 2"



p. 74

#### SPN

Deflector-style; high impact, narrow fan spray. 1/4" - 3/4"



p. 75

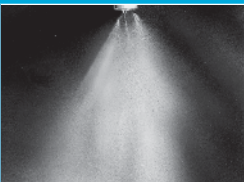

### Misting Nozzles

Misting nozzles are characterized by their very small droplet size and relatively small flow rate. The pressure of the incoming fluid is used to drive the atomization process. Higher liquid pressures produce increasingly finer droplets.

#### MicroWhirl

Low profile and super-fine atomization. 1/8", 1/4", 3/8"-24UNF



p. 76

#### PJ

Combines small size and super-fine atomization. 1/8" or 1/4"



p. 77

#### P

Liquid "impinges" on pin for extra-fine atomization. 1/4"



p. 78

#### L

A low-flow, spiral nozzle.



1/8" or 1/4"  
p. 79

#### UltiMist

Misting nozzles produce high number of droplets under 60 microns. 1/8" - 1/4"



p. 80

#### SS

Durable nozzle with multiple fan patterns to provide dense fog. 3/4" - 1 1/4"



p. 81



### Air Atomizing Nozzles

Compressed gas, most often air, is used to increase the atomization efficiency of these nozzles.

#### XA

Two-fluid nozzles for low flow applications. Automatic options available. 0.006-4.54 L/min



pp. 82-99

#### SAM

External mix/flat fan or narrow round variable coverage, fine control of droplet size. 0.05-2.96 L/min



pp. 100, 101

#### SpiralAir

Two-fluid nozzles for high flow applications. 1.24-75 L/min



pp. 102, 103



### Automatic Nozzles

Electric-actuated or air-actuated intermittent spraying solutions ensure precision volumes of expensive ingredients and compounds are sprayed directly onto your processing target, with overspray waste virtually eliminated.

#### HydroPulse EHP

Electric actuated food grade hygienic design with interchangeable tips. 0.084-101 L/min



pp. 24, 25

#### HydroPulse EHPI

For industrial applications - electric actuated with interchangeable tips. 0.084-101 L/min



pp. 24, 25

#### HydroPulse PHP

Pneumatically actuated for crisp on/off spray with interchangeable tips. 0.084-101 L/min



pp. 26, 27

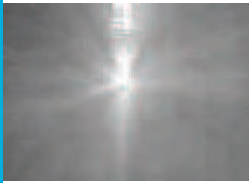

**Tank Washing Nozzles**

These specialized products are customized to the task of cleaning the interior surfaces of tanks. The typical 360° spray pattern covers all internal surfaces while specialized 270° and 180° patterns focus the cleaning fluid on specific surfaces. Models range from basic fixed nozzles to advanced fluid-driven tank cleaning machines.

**HydroWhirl S**

Slotted, rotating tank washing spray nozzle. Available with ATEX approval for Zone 0.  
1/8" - 1-1/2"  
p. 105



**HydroWhirl Poseidon**

Rotating tank washing nozzle in PTFE. Ideal for harsh chemical environments.  
1/2" - 1-1/2"  
p. 106



**HydroWhirl Orbitor**

High impact rotary tank cleaning machine. 360° and 180° wash patterns. 2 or 4 nozzle configurations  
p. 107



**HydroWhirl Orbitor 100**

High impact rotary tank cleaning machine ideal for small to medium tanks.  
p. 108



**HydroClaw**

Unique, clog-resistant design with vigorous 360° rinsing action for food-grade applications.  
3/4" - 1-1/2"  
p. 109



**TW**

Compact design; fits small openings. Unique patterns that spray in opposing directions.  
3/8" & 1"  
p. 110



**CLUMP**

A tank washing manifold with 6 large free passage MaxiPass nozzles.  
3/4" - 1"  
p. 111



**LEM**

A special tank washing assembly with omni-directional spray.  
3/4" & 1"  
p. 112



**Special Purpose Nozzles and Accessories**

Applications with very specific requirements require specialized nozzles. Nozzles for fire control, spray drying, submerged tank mixing, the paper industry, and air blowoff are some that require application-specific designs.

**FIRE PROTECTION NOZZLES**

**AFF**

FM Approved extra-wide flat fan for fire protection water wall.  
3/4" & 1/2"  
p. 113



**N**

Specially designed for fire protection. Factory Mutual, UL, U.S. Coast Guard, and Lloyd's Register approved models.  
1/2" - 1 1/2"  
p. 114



**TF29-180**

Ultra-wide fire protection nozzle has full cone spray coverage close to the nozzle  
1/2"  
p. 115



**SPRAY DRYING NOZZLES**

**Twist & Dry**

Stainless steel, FDA-compliant nozzles for food processing and spray drying applications.  
1/4" - 3/4"  
pp. 116-120



**TDL**

Stainless steel, FDA-compliant nozzles with low flow rates for food processing and spray drying applications.  
1/8" - 3/8"  
p. 120



**TurboMix**

Tank-mixing eductor nozzle. Inherently clog resistant.  
3/8" - 8"  
p. 121



**IS**

Mounted in pairs for rectangular coverage.  
1/16" - 1 1/2"  
p. 122



**LP**

Self-aligning, interchangeable family of shower nozzles.  
p. 123



**PSR**

Small physical size, hard-driving high velocity, straight jet  
9/16" - 24 UNEF  
p. 124



**FINZ**

High-impact air fan nozzle, versatile cleaning nozzle.  
1/4"  
p. 125



**SJ**

Swivel joints allow custom alignment of nozzles without piping changes.  
1/4" - 3/4"  
p. 126

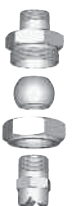

**Accessories**

Strainers, bushings, adapters, couplings, manifolds, and flanges to complete your installation.



p. 127

# ...by APPLICATION

Choosing the correct nozzle for your application from BETE's 20,000+ products can be daunting. To help, here is a list of some of the more common uses for spray nozzles. Each application is followed by several BETE nozzle series which have been used in this application. The series used most often is listed first.

The operating pressures, flow rate, and spray angle ranges are typical for each application. The full operating range for each series is generally broader.

If you don't see your application, or need advice making a nozzle selection, please **call us** at 413-772-0846.

## Absorption

Scrub hydrofluoric acid, ammonia, and other highly soluble gases

<b>TF</b> 3.5-7 bar 2-10 l/min 90°-120° p. 28	<b>TFXP</b> 3.5-7 bar 2-10 l/min 90°-120° p. 29	<b>TH</b> 0.5-1 bar 371-2230 l/min 54°-95° SNBSC avail. pp. 58, 59	<b>MaxiPass</b> 0.5-1 bar 371-2230 l/min 90°-120° lumpy liquids pp. 34, 35	<b>NC</b> 0.5-1 bar 371-2230 l/min 90°-120° pp. 42, 43	<b>SC</b> 0.5-1 bar 371-2230 l/min 90°-120° metal nozzle pp. 40, 41
---	---	---	---	--	--

## Additives

Apply small volumes of a solution onto moving product or into a mixture

<b>XA</b> 1.5-4 bar 0.4-7 l/h 20°-60° 2.4-14 Nm³/h pp. 82-99	<b>NF</b> 4-7 bar 0.1-0.4 l/min 65°-120° p. 67	<b>BJ</b> 4-7 bar 0.03-0.4 l/min 50°-80° pp. 62, 63	<b>SAM</b> 0.7-1 bar 20°-70° 0.8-7.2 Nm³/h pp. 100, 101	<b>HydroPulse</b> 2-40 bar 0.03-55 l/min p. 24-27
---	--	---	---	--

## Aeration

Aerate waste water treatment, fish ponds, and impoundment ponds

<b>TF</b> 1.5-3.5 bar 10-40 l/min 90°-120° p. 28	<b>TFXP</b> 1.5-3.5 bar 10-40 l/min 90°-120° lumpy liquids p. 29	<b>MaxiPass</b> 0.7-3 bar 5-40 l/h 90°-120° lumpy liquids pp. 34, 35
--	---	---

## Air and Steam

Clean or dry product moving past nozzle; inject gases and odorants into process lines; sparging; bubbling

<b>NF (D,S)</b> 3-5 bar 4.0-102 l/min 0.6-90 Nm³/h pp. 68, 69	<b>FF</b> 3-5 bar 4.0-102 l/min 0.3-90 Nm³/h pp. 70, 71	<b>SPN</b> 3-5 bar 4.0-102 l/min 0.6-90 Nm³/h p. 75
---	---	---

## Air Conditioning

Cooling air at gas turbine inlets

<b>PJ</b> 4-70 bar 0.05-5.34 l/h 90° p. 77	<b>XA</b> 1.5-4 bar 0.4-7 l/h 20°-60° 2.4-14 Nm³/h pp. 82-99	<b>MicroWhirl</b> 70-200 bar 0.04-0.60 l/min 20°-70° p. 76
--	---	--

## Air Nozzle

Blowoff nozzle uses compressed air only

<b>FINZ</b> 0.7-6 bar 7-65 Nm³/h p. 125
--

## Blow off Nozzles

Remove water or dust from strips and conveyors

<b>NF</b> 3-5 bar 4.0-102 l/min 0.6-90 Nm³/h p. 67	<b>FF</b> 3-5 bar 4.0-102 l/min 0.3-90 Nm³/h pp. 70, 71	<b>SPN</b> 2-30 bar 3.2-100 l/min 0.6-90 Nm³/h p. 75	<b>FINZ</b> 0.7-6 bar 7-65 Nm³/h p. 125
--	---	--	--

### Color Code:

- Automatic
- Full Cone
- Hollow Cone
- Fan
- Misting
- Air Atomizing
- Tank Washing
- Special Purpose



**Car Wash Nozzles**

High pressure wash nozzles used in automated car wash units.

<b>NF</b> 3-5 bar 4.0-102 l/min 120° pp. 68, 69	<b>FF</b> 3-5 bar 4.0-102 l/min 105°-145° pp. 70, 71	<b>SPN</b> 2-30 bar 3.2-100 l/min 35°-50° p. 75	<b>BJH</b> 2-70 bar 0.048-16.6 l/min p. 64	<b>NFH</b> 2-70 bar 0.048-16.6 l/min p. 65
---	--	---	---	---

**Clean in Place Nozzles**

Rotating and stationary bottle, drum, and tank washing nozzles

<b>HydroWhirl S</b> 10-60 psi 1.26-90.9 gpm 360° efficient clean p. 105	<b>HydroWhirl Poseidon</b> 10-60 psi 50.3-89.5 gpm 360° PTFE p. 106	<b>HydroWhirl Orbitor</b> 45-145 psi 21.5-160 gpm 180°, 360° high-impact p. 107	<b>HydroWhirl Orbitor 100</b> 45-145 psi 12-52.4 gpm 180°, 360° high-impact p. 108	<b>HydroClaw</b> 25-40 psi 33-112 gpm 360° clog-resistant p. 109	<b>TW</b> 30- 60 psi 5.2- 63.0 gpm 180°- 270° very compact p. 110
--	--	--	---	---	--

**Clog-resistant Nozzles**

Wide free passage to spray lumpy, viscous liquids with less clogging

<b>MaxiPass</b> 0.2-5 bar 2.8-3400 l/min 30°-120° lumpy liquids pp. 34, 35	<b>TFXP</b> 0.5-20 bar 9.7-10700 l/min 90°-120° lumpy liquids p. 29	<b>TH</b> 0.2-3 bar 15.3-2230 l/min 54°-95° SNBSC avail. pp. 58, 59	<b>WTZ</b> 0.5-10 bar 0.8-70.4 l/min 90°-110° p. 37	<b>SPN</b> 0.7-15 bar 1.9-177 l/min 15°-50° p. 75	<b>FF</b> 0.2-10 bar 0.05-757 l/min 145° pp. 70, 71
---	--	--	---	---	---

**Coating**

Apply thin coatings (wet or dry) on product moving past nozzles

<b>XA</b> 1.5-4 bar 11-265 l/h 20° 0.6-16 Nm³/h pp. 82-99	<b>NF (D,S)</b> 2-5.5 bar 0.8-64 l/min 50°-120° pp. 67-69	<b>BJ</b> 2-5.5 bar 0.3-40 l/min 25°-80° pp. 62, 63	<b>PJ</b> 4-7 bar 0.05-1.7 l/min 90° p. 77	<b>L</b> 3-7 bar 1-4 l/min 90° p. 79	<b>SAM</b> 0.7-1 bar 20°-70° 0.8-7.2 Nm³/h pp. 100, 101	<b>HydroPulse</b> 2-40 bar 0.03-55 l/min p. 24-27
--	---	---	--	--	---	--

**Concrete Curing**

Humidify concrete to control curing process

<b>XA</b> 2-4 bar 3.2-93 l/hr 20°- 70° 0.9-24 Nm³/h pp. 82-99	<b>PJ</b> 5-70 bar 0.058-5.34 l/min 90° p. 77	<b>MicroWhirl</b> 70-200 bar 0.04-0.60 l/min 20°-70° p. 76
--	---	--

**Cooling: Deluge**

Process cooling for food, chemical, and industrial processes

<b>TF</b> 0.7-1.5 bar 45-945 l/min 90°-120° p. 28	<b>MaxiPass</b> 0.2-1.5 bar 23-940 l/min 90°-120° lumpy liquids pp. 34, 35	<b>WL</b> 0.3-1.5 bar 2-53 l/min 80°-120° p. 32	<b>NC</b> 0.2-1.5 bar 23-940 l/min 90°-120° pp. 42, 43	<b>TC</b> 0.1-0.7 bar 820-13250 l/min 60°-120° p. 47
---	---	---	--	--

**Cooling: Evaporative**

Cool hot (+ 300°F) flue gases prior to entering a baghouse or temperature-sensitive equipment

<b>SpiralAir</b> 3-7 bar 1.2-68 l/min 20°-60° 40-220 Nm³/h pp. 102, 103	<b>TF -full</b> 4-10 bar 6-68 l/min 90°-120° p. 28	<b>TF -hollow</b> 4-10 bar 6-68 l/min 90°-120° p. 53	<b>TFXP</b> 4-10 bar 6-68 l/min 90°-120° lumpy liquids p. 29	<b>L</b> 4-14 bar 1.2-21 l/min 90° p. 79	<b>P</b> 4-14 bar 1.2-21 l/min 90° p. 78	<b>XA</b> 1.5-4 bar 11-100 l/h 20°-60° 1.2-19 Nm³/h pp. 82-99	<b>MicroWhirl</b> 70-200 bar 0.04-0.60 l/min 20°-70° p. 76
--	--	--	---	--	--	--	--

**Cooling: Parts**

Cool hot parts on conveyors from pre-treatment ovens

<b>MaxiPass</b> 0.7-4 bar 4.77-888 l/min 90°-120° lumpy liquids pp. 34, 35	<b>WL</b> 0.7-4 bar 0.5-94 l/min 90°-120° p. 32	<b>SC</b> 0.7-4 bar 11.3-640 l/min 90°-120° metal nozzle pp. 40, 41	<b>TFXP</b> 0.7-4 bar 2.7-588 l/min 90°-120° p. 29	<b>TF</b> 0.7-4 bar 2.7-588 l/min 90°-120° p. 28	<b>MPL</b> 0.7-6 bar 0.44-7.97 l/min 90°-120° p. 33
---	---	--	--	--	---

**Cooling: Pond**

Cool pond water; heat recovery

<b>TFXP</b> 0.5-1 bar 75-454 l/min 90°-120° lumpy liquids p. 29	<b>TF -full</b> 0.5-1 bar 75-454 l/min 90°-120° p. 28	<b>TF -hollow</b> 0.5-1 bar 75-454 l/min 90°-120° p. 53	<b>TH</b> 0.2-1 bar 61-341 l/min 80°-100° pp. 58, 59	<b>MaxiPass</b> 0.7-1.5 bar 23-341 l/min 90° pp. 34, 35
--	---	---	--	---

**Debarking**  
Remove bark from logs prior to pulping

<b>NF</b> 3-70 bar 4-5250 l/min 30°-90°  p. 67	<b>SPN</b> 3-4 bar 7.9-91.2 l/min 35°-50°  p. 75	<b>BJH</b> 2-70 bar 0.048-16.6 l/min  p. 64	<b>NFH</b> 2-70 bar 0.048-16.6 l/min  p. 65
---	---	---	---

**Disposal: Evaporative**  
Evaporate tailing ponds or volatile waste

<b>TFXP</b> 3-8 bar 10-265 l/min 90°-120° lumpy liquids p. 29	<b>TF -full</b> 3-8 bar 10-265 l/min 90°-120°  p. 28	<b>TF -hollow</b> 4-10 bar 6-68 l/min 90°-120°  p. 53	<b>MaxiPass</b> 3-8 bar 21-246 l/min 90°-120° lumpy liquids pp. 34, 35
--	---	--	---

**Distribution**  
Distribute fluids uniformly onto packing, trickle bed media, and horticultural beds; VOC stripping

<b>NC</b> 0.2-1.5 bar 11-13250 l/min 90°-120° plastic nozzle pp. 42, 43	<b>SC</b> 0.2-1.5 bar 7.6-1597 l/min 90°-120° metal nozzle pp. 40, 41	<b>MaxiPass</b> 0.2-1.5 bar 4-1930 l/min 90°-120° lumpy liquids pp. 34, 35	<b>TC</b> 0.1-0.7 bar 820-13250 l/min 60°-120°  p. 47	<b>IS</b> 0.05-0.7 bar 2-435 l/min used in pairs lumpy liquids p. 122	<b>WL</b> 0.3-1.5 bar 4-57 l/min 90°-120°  p. 32
--	--	---	--	--	---

**Drying**  
Remove excess water after washing or rinsing

<b>NF</b> 3-5 bar 0.6-90 Nm³/h  p. 67	<b>FF</b> 3-5 bar 0.3-90 Nm³/h  pp. 70, 71	<b>SPN</b> 3-5 bar 0.6-90 Nm³/h  p. 75	<b>FINZ</b> 0.7-6 bar 7-65 Nm³/h  p. 125
---	--	--	--

**Dust Control: Air-handling Ducts**  
Suppress stone, coal and other dust in vent ducts; control paint spray carry-over

<b>TF</b> 2-5.5 bar 4.5-43 l/min 90°-120°  p. 28	<b>TFXP</b> 2-5.5 bar 19.5-43 l/min 90°-120° lumpy liquids p. 29	<b>MaxiPass</b> 3-5.5 bar 9-47 l/min 90°-120° lumpy liquids pp. 34, 35	<b>SpiralAir</b> 3-7 bar 1.2-68 l/min 20°-60° 40-220 Nm³/h pp. 102, 103	<b>L</b> 3-5.5 bar 1-13 l/min 90° very fine dust p. 79	<b>P</b> 3-5.5 bar 0.25-14.5 l/min 90° very fine dust p. 78	<b>MicroWhirl</b> 70-200 bar 0.09-0.28 l/min 90°  p. 76
---	---	---	--	---	--	--

**Dust Control: Area**  
Suppress dust at conveyor transfer points, dump pits, and loading hoppers

<b>TF</b> 2-5.5 bar 4.6-43 l/min 90°-120°  p. 28	<b>TF150</b> 2-5.5 bar 20-57 l/min 150° wide coverage p. 28	<b>MaxiPass</b> 3-5.5 bar 9-47 l/min 90°-120° lumpy liquids pp. 34, 35	<b>TFXP</b> 2-5.5 bar 20-57 l/min 90°-120° lumpy liquids p. 29	<b>TF170</b> 2-5.5 bar 20-57 l/min 170° wide coverage p. 28	<b>L</b> 3-5.5 bar 1-14.5 l/min 90° transfer point p. 79
---	--	---	---	--	---

**Etching: Electronics**  
Wash and rinse circuit boards and wafers

<b>WL</b> 0.7-3 bar 0.5-15.1 l/min 60°-120°  p. 32	<b>NF (D,S)</b> 0.7-3 bar 0.5-26.5 l/min 50°-120°  pp. 68, 69	<b>SPN</b> 0.7-3 bar 1.8-15 l/min 35°-50°  p. 75	<b>FF</b> 0.2-1.5 bar 0.05-14 l/min 145°  pp. 70, 71
---	--	---	---

**EZ Change/ 1/4 Turn Nozzles**  
Quick change-out nozzle base assembly with 1/4-turn ramped engagement

<b>EZ</b> FF, NF, SPN 0.2-35 bar 0.05-162 l/min 0°-145°  pp. 72, 73	<b>EZ</b> WL, TF 0.2-35 bar 0.13-206 l/min 30°-120°  p. 38	<b>EZ</b> WL, TF, WT 0.2-35 bar 0.13-206 l/min 30°-120°  p. 54, 55
--	---	---

**Color Code:**

- Automatic
- Full Cone
- Hollow Cone
- Fan
- Misting
- Air Atomizing
- Tank Washing
- Special Purpose

**Fire Protection:**

**Deluge**

Protect offshore platforms, storage tanks, hazardous loading areas, and equipment bays

**N**  
4-10 bar  
200-1300 l/min  
90°-120°  
FM approved  
p. 114

**TFXP**  
4-10 bar  
200-1140 l/min  
90°-120°  
lumpy liquids  
p. 29

**MaxiPass**  
4-8 bar  
178-674 l/min  
90°-120°  
lumpy liquids  
pp. 34, 35

**TF150**  
4-10 bar  
200-1140 l/min  
150°  
wide coverage  
p. 28

**Fire Protection:**

**Special**

Protect coal conveyors; fueling and vulcanizing cabinets; warehouses and munitions storage

**AFF**  
FM Approved  
3.4-10.3 bar,  
25.3-263 l/min,  
135°-144°  
p. 113

**N**  
4-10 bar  
200-1300 l/min  
90°-120°  
FM A  
p. 114

**TF29-180**  
4-10 bar  
35-246 l/min  
180°  
wide coverage  
p. 115

**SpiralAir**  
3-7 bar  
1-72 l/min  
20°-40°  
37-185 Nm<sup>3</sup>/h  
pp. 102, 103

**CW**  
3-14 bar  
1-8.3 l/min  
80°-120°  
p. 36

**Fire Protection:**

**Water Wall**

Protect personnel, evacuation muster areas, equipment, and structures from heat radiation

**AFF**  
FM Approved  
3.4-10.3 bar,  
25.3-263 l/min,  
135°-144°  
p. 113

**TF**  
4-10 bar  
200-1140 l/min  
90°-120°  
p. 28

**TF150**  
4-10 bar  
200-1140 l/min  
150°  
wide coverage  
p. 28

**TF170**  
4-12 bar  
200-1140 l/min  
170°  
horiz. spray  
p. 28

**NF (D,S)**  
4-8 bar  
76-738 l/min  
90°-120°  
pp. 68, 69

**FF**  
4-8 bar  
64-570 l/min  
145°  
wall wetting  
pp. 70, 71

**TFXP**  
4-10 bar  
200-1140 l/min  
90°-120°  
lumpy liquids  
p. 29

**Foam Control**

Control build-up of foam in aeration and settling basins; mixing vessels and below weirs; and spillways

**MaxiPass**  
0.2-1 bar  
6-435 l/min  
90°-120°  
lumpy liquids  
pp. 34, 35

**WL**  
0.4-1.5 bar  
11-53 l/min  
90°-120°  
p. 32

**SC**  
0.2-1 bar  
6.3-320 l/min  
90°-120°  
pp. 40, 41

**TFXP**  
4-10 bar  
200-1140 l/min  
90°-120°  
lumpy liquids  
p. 29

**Fog Nozzles**

Fine atomization misting; movie special effects

**PJ**  
5-15 bar  
0.06-2.5 l/min  
90°  
p. 77

**TF -full**  
3-70 bar  
5.5-76 l/min  
90°-120°  
p. 28

**TF -hollow**  
4-10 bar  
6-68 l/min  
90°-120°  
p. 53

**XA**  
0.7-4 bar  
1.1-110 l/h  
20°-40°  
pp. 82-99

**UltiMist**  
40-150 bar  
5.3-84 l/hr  
50°-110°  
p. 80

**MicroWhirl**  
70-200 bar  
0.04-0.60 l/min  
20°-70°  
p. 76

**Food Processing**

Apply flavors, colors, oils, preservatives, antimicrobials, and mold inhibitors

**XA**  
0.7-7 bar  
16-227 l/h  
20°-120°  
pp. 82-99

**FF**  
0.7-5 bar  
0.1-18.3 l/min  
145°  
pp. 70, 71

**HydroPulse**  
2-40 bar  
0.03-55 l/min  
p. 24-27

**Gas Scrubbing**

Spray reagent into gas

**STXP**  
0.4-1 bar  
227-2460 l/min  
90°-120°  
recycle slurry  
p. 31

**ST**  
0.4-1 bar  
227-2460 l/min  
90°-120°  
resist erosion  
p. 30

**MaxiPass**  
0.2-1.5 bar  
200-1930 l/min  
90°-120°  
recycle slurry  
pp. 34, 35

**TH**  
0.2-1.5 bar  
170-2300 l/min  
90°-120°  
SNBSC avail.  
pp. 58, 59

**NC**  
0.2-1.5 bar  
42-1597 l/min  
90°-120°  
plastic nozzle  
pp. 42, 43

**SC**  
0.2-1.5 bar  
91-1300 l/min  
90°-120°  
metal nozzle  
pp. 40, 41

**Humidification**

Humidify air in ducts, drying kilns, curing rooms, greenhouses, and other open areas; area misting

**XA**  
2-4 bar  
1.5-113 l/h  
20°-40°  
1-27 Nm<sup>3</sup>/h  
pp. 82-99

**PJ**  
4-14 bar  
0.5-2.4 l/min  
90°  
p. 77

**TF**  
5.5-14 bar  
7-23 l/min  
120°  
hollow cone  
p. 28

**L**  
5.5-14 bar  
1.5-13 l/min  
90°  
p. 79

**SpiralAir**  
4-7 bar  
1.1-57 l/min  
20°-60°  
59-225 Nm<sup>3</sup>/h  
pp. 102, 103

**MicroWhirl**  
70-200 bar  
0.04-0.60 l/min  
20°-70°  
p. 76

**Large Free Passage Nozzle**

Clog resistant; allow lumpy viscous liquids to pass easily

**MaxiPass**  
0.2-5 bar  
2.8-3400 l/min  
30°-120°  
pp. 34, 35

**TFXP**  
0.5-20 bar  
9.7-10700 l/min  
90°-120°  
p. 29

**TH**  
0.2-3 bar  
15.3-2230 l/min  
90°-120°  
SNBSC avail.  
pp. 58, 59



**Lubrication**

Lubricate dies and moulds; roll bite in strip mills

<b>XA</b>
1.5-4 bar 0.4-7 l/h 20°-60° 3-40 Nm <sup>3</sup> /h pp. 82-99

<b>NF (D,S)</b>
4-7 bar 0.1-0.4 l/min 65°- 120° pp. 68, 69

<b>BJ</b>
4-7 bar 0.03-0.4 l/min 50°- 80° pp. 62, 63

<b>HydroPulse</b>
2-40 bar 0.03-55 l/min p. 24-27

**Mist Eliminator Wash**

Clean mist eliminators in packed or open tower scrubbers

<b>NC</b>
1-3 bar 15.8-114 l/min 90° pp. 42, 43

<b>MaxiPass</b>
1.5-4 bar 6.4-60 l/min 90° pp. 34, 35

<b>WL</b>
1.5-5.5 bar 0.7-106 l/min 90°-120° p. 32

**Misting**

Moisten paper; mist produce; compost piles of crushed products

<b>UltiMist</b>
15-150 bar 1.8-17 l/hr 60°- 110° p. 80

<b>PJ</b>
7-150 bar 0.1-50 l/min 90° p. 77

<b>XA</b>
3-7 bar 0-330 l/h 60°-120° pp. 82-99

<b>TF -full</b>
3-30 bar 5.5-75 l/min 90°- 120° p. 28

<b>TF -hollow</b>
4-10 bar 6-68 l/min 90°-120° p. 53

<b>MicroWhirl</b>
70-200 bar 0.04-0.60 l/min 20°-70° p. 76

**Mixing Eductors**

Keep solids suspended by eduction

<b>TurboMix</b>
0.7-7 bar 40-1000 l/min p. 121

**Moistening**

Wetting, humidifying products on conveyor

<b>XA</b>
3-7 bar 3.4-320 l/h 60°-120° pp. 82-99

<b>PJ</b>
7-140 bar 0.1-0.2 l/min 90° p. 77

<b>LP</b>
4-35 bar 1.9-167 l/min 0°-60° p. 123

<b>MicroWhirl</b>
70-200 bar 0.04-0.60 l/min 20°-70° p. 76

<b>HydroPulse</b>
2-40 bar 0.03-55 l/min p. 24-27

**Odor Control**

Spray odor neutralizing agents

<b>XA</b>
3-7 bar 0-16 l/h 60°-120° pp. 82-99

<b>PJ</b>
7-150 bar 0.14-5 l/min 90° p. 77

<b>MicroWhirl</b>
70-200 bar 0.09-0.28 l/min 90° p. 76

<b>SpiralAir</b>
3-7 bar 1.2-68 l/min 20°-60° 40-220 Nm <sup>3</sup> /h pp. 102, 103

**Packing**

Distribute scrubbing liquor in scrubbers or water in humidifiers

<b>NC</b>
0.2-1.5 bar 11-13250 l/min 120° plastic nozzle pp. 42, 43

<b>SC</b>
0.2-1.5 bar 7.6-1597 l/min 90°-120° metal nozzle pp. 40, 41

<b>MaxiPass</b>
0.2-1.5 bar 4-1930 l/min 90°- 120° lumpy liquids pp. 34, 35

<b>TC</b>
0.1-0.7 bar 820-13250 l/min 60°-120° metal nozzle p. 47

<b>IS</b>
0.05-0.7 bar 2-435 l/min used in pairs lumpy liquids p. 122

<b>WL</b>
0.3-1.5 bar 4-57 l/min 90°-120° p. 32

**Pollution Control**

Distribute slurry in open towers

<b>STXP</b>
0.4-1 bar 227-2460 l/min 90°-120° RBSC avail p. 31

<b>ST</b>
0.4-1 bar 227-2460 l/min 90°-120° RBSC avail p. 30

<b>MaxiPass</b>
0.2-1.5 bar 200-1930 l/min 90°-120° recycle slurry pp. 34, 35

<b>TH</b>
0.2-1.5 bar 170-2300 l/min 90°-120° SNBSC avail. pp. 58, 59

<b>NC</b>
0.2-1.5 bar 42-1597 l/min 90°-120° plastic nozzle pp. 42, 43

<b>SC</b>
0.2-1.5 bar 91-1300 l/min 90°-120° metal nozzle pp. 40, 41

**Pulp Bleaching**

Wall wash  
bleaching tanks

**FF**  
1.5-4 bar  
0-196 l/min  
105°-145°  
pp. 70, 71

**NF**  
3-7 bar  
4-36 l/min  
20°-60°  
p. 67

**Quench**

Evaporatively quench  
hot gases

**SpiralAir**  
2-7 bar  
2-80 l/min  
25-135 Nm<sup>3</sup>/h  
20°-90°  
pp. 102, 103

**L**  
5.5-14 bar  
1.5-6.8 l/min  
90°  
p. 79

**TF -full**  
3-8 bar  
5.5-84.1 l/min  
90°-120°  
p. 28

**TF -hollow**  
4-10 bar  
6-68 l/min  
90°-120°  
p. 53

**XA**  
3-4 bar  
2.6-167 l/h  
20°-40°  
1.8-27 Nm<sup>3</sup>/h  
pp. 82-99

**PJ**  
4-70 bar  
0.03-5.3 l/min  
90°  
p. 77

**MicroWhirl**  
70-200 bar  
0.04-0.60 l/min  
20°-70°  
p. 76

**Roll Cooling**

Cool rolls in steel  
strip mills

**NF (D,S)**  
0.7-3 bar  
0.5-26.5 l/min  
60°-120°  
pp. 68, 69

**Scrubbing:**

**Conditioning**

Inject ammonia or water  
upstream of electrostatic  
precipitators; inject odor  
control additives

**XA**  
2-4 bar  
1.5-113 l/h  
20°-40°  
1-27 Nm<sup>3</sup>/h  
pp. 82-99

**PJ**  
4-14 bar  
0.05-2.4 l/min  
90°  
p. 77

**L**  
5.5-14 bar  
1.5-6.8 l/min  
90°  
p. 79

**SpiralAir**  
4-7 bar  
1.1-57 l/min  
59-150 Nm<sup>3</sup>/h  
20°-60°  
pp. 102, 103

**MicroWhirl**  
70-200 bar  
0.04-0.60 l/min  
20°-70°  
p. 76

**Scrubbing:**

**Direct Contact**

Spray water or reagent  
slurry into open tower;  
flue gas desulphurization

**STXP**  
0.4-1 bar  
227-2460 l/min  
90°-120°  
recycle slurry  
p. 31

**ST**  
0.4-1 bar  
227-2460 l/min  
90°-120°  
resist erosion  
p. 30

**MaxiPass**  
0.2-1.5 bar  
200-1930 l/min  
90°-120°  
recycle slurry  
pp. 34, 35

**TH**  
0.2-1.5 bar  
170-2300 l/min  
90°-120°  
SNBSC avail.  
pp. 58, 59

**NC**  
0.2-1.5 bar  
42-1597 l/min  
90°-120°  
plastic nozzle  
pp. 42, 43

**SC**  
0.2-1.5 bar  
91-1300 l/min  
90°-120°  
metal nozzle  
pp. 40, 41

**TF**  
3-8 bar  
5.5-84.1 l/min  
90°-120°  
p. 28

**Scrubbing:**

**Dry**

Inject lime slurry; inject  
food and chemical prod-  
uct into spray dryer

**SpiralAir**  
3.5-7 bar  
5.3-57 l/min  
20°-60°  
45-225 Nm<sup>3</sup>/h  
pp. 102, 103

**XA**  
3-4 bar  
2.6-167 l/h  
20°-40°  
1.8-27 Nm<sup>3</sup>/h  
pp. 82-99

**WT**  
4-10 bar  
0.45-57 l/min  
80°-130°  
pp. 48, 49

**WTX**  
4-10 bar  
0.45-57 l/min  
80°-130°  
pp. 50, 51

**Color Code:**

- Automatic
- Full Cone
- Hollow Cone
- Fan
- Misting
- Air Atomizing
- Tank Washing
- Special Purpose

**Self Cleaning**

**Nozzles/ Showers**

Clean webs in paper  
mills, wash or rinse steel  
strip or conveyor belts

**LP**  
4-35 bar  
1.9-167 l/min  
30°- 60°  
p. 123

**BJH**  
2-70 bar  
0.048-16.6  
l/min  
p. 64

**NFH**  
2-70 bar  
0.048-16.6  
l/min  
p. 65

**Spray Drying**

Processing of milk, other  
foods and chemical products

**Twist & Dry**  
15-350 bar  
35.3-5970 l/h  
50°- 80°  
pp. 116-120

**TDL**  
15-350 bar  
11.3-469 l/h  
70°-75°  
p. 120

**TD-K**  
15-350 bar  
11.3-469 l/h  
70°-75°  
pp. 118

**SpiralAir**  
2-7 bar  
2-80 l/min  
45-139 Nm<sup>3</sup>/h  
20°-90°  
pp. 102, 103

**Street Flushing & Cleaning**

High impact wash down,  
clear loose debris from  
streets; walkways

**FF**  
1.7-7 bar  
8.3-74 l/min  
145°  
wide coverage  
pp. 70, 71

**SPN**  
1.7-7 bar  
8.3-74 l/min  
15°-50°  
high impact  
p. 75

**NF**  
1.7-7 bar  
85-763 l/min  
50°-90°  
p. 67

**BJH**  
2-70 bar  
0.048-16.6  
l/min  
p. 64

**NFH**  
2-70 bar  
0.048-16.6  
l/min  
p. 65

**Washing:  
Conveyor**

Wash coal, sand, gravel, and crushed rock; pre-wet to reduce dust at hoppers and transfer points

NF (D,S)
0.4-4 bar 5.3-1700 l/min 65°-120° pp. 68, 69

SPN
0.7-5.5 bar 7.6-106 l/min 15°-50° high impact p. 75

FF
0.2-4 bar 1.5-110 l/min 145° wide coverage pp. 70, 71

MaxiPass
0.2-3 bar 2.6-144 l/min 60°-120° lumpy liquids pp. 34, 35

TFXP
0.5-3 bar 10-159 l/min 90°-120° lumpy liquids p. 29

L
3-4 bar 1-11 l/min 90° transfer point p. 79

**Washing:  
Intermittent**

Periodic wash down of mist eliminator, filter pads, sieve screens, and distribution plates

NC
1-3 bar 15.8-114 l/min 60°-120° plastic nozzle pp. 42, 43

MaxiPass
1.5-4 bar 6.4-60 l/min 60°-120° lumpy liquids pp. 34, 35

WL
1.5-5.5 bar 0.7-106 l/min 80°-120° p. 32

SC
1-3 bar 17-121 l/min 60°-120° metal nozzle pp. 40, 41

**Washing:  
Parts**

High impact parts washing and surface preparation

NF (D,S)
1.5-5.5 bar 0.7-106 l/min 65°-120° pp. 68, 69

SPN
0.7-5.5 bar 7.6-106 l/min 15°-50° high impact p. 75

WL
0.7-4 bar 1.4-98 l/min 90°-120° p. 32

NC
0.7-3 bar 14-144 l/min 60°-120° plastic nozzle pp. 42, 43

SC
0.7-3 bar 11-167 l/min 60°-120° metal nozzle pp. 40, 41

SF
1-5.5 bar 2.3-56 l/min 35°-95° p. 74

**Washing:  
Tank**

Rinsing and solvent cleaning of tanks, drums, and process equipment

HydroWhirlS
10-60 psi 1.26-90.9 gpm 360° efficient clean p. 105

HydroWhirl Poseidon
10-60 psi 50.3-89.5 gpm 360° PTFE p. 106

HydroWhirl Orbitor
45-145 psi 21.5-160 gpm 180°, 360° high-impact p. 107

HydroWhirl Orbitor 100
45-145 psi 12-52.4 gpm 180°, 360° high-impact p. 108

HydroClaw
25-40 psi 33-112 gpm 360° clog-resistant p. 109

TW
30- 60 psi 5.2- 63.0 gpm 180°- 270° very compact p. 110

CLUMP
40-60 psi 13.8- 68 gpm 360° lumpy liquids p. 111

LEM
40- 60 psi 8.4- 121 gpm 360° even rinsing p. 112

**Venturi Scrubbing**  
Keep solids suspended by injection

NCK
0.5-7 bar 23.1-4660 l/min 30° p. 45

NCJ
0.5-7 bar 23.1-4660 l/min 30° p. 57

**Color Code:**

- Automatic
- Full Cone
- Hollow Cone
- Fan
- Misting
- Air Atomizing
- Tank Washing
- Special Purpose



# MATERIALS

BETE manufactures nozzles in hundreds of different materials and combinations of materials. The chart on this page shows the 40 materials most often specified. If you don't know which material is best for your application, BETE Applications Engineering can help you with your selection. Some factors that influence the nozzle material selection process are:

**Temperature.** Melting or softening of material establishes maximum temperature limits. However, these temperature limits must be reduced when corrosion, oxidation, or chemical attack are also present. See column in blue for general temperature limits for various materials.

**Corrosion.** Plastics offer superior corrosion resistance at relatively low cost, but can only be used in low-temperature applications. In general, metals can be ranked in the following order of corrosion resistance (from lowest to highest): cast iron, brass, stainless steels, nickel-based alloys, refractory metals and precious metals. Ceramics have excellent corrosion resistance except in very high pH environments.

**Chemical attack.** There are few general guidelines to this complex subject, but the material used for piping may provide a useful indicator of a suitable nozzle material.

If the environment of your application is known to contain substances which may attack the spray

nozzle, contact BETE Applications Engineering for advice. **Abrasion.** Hardened stainless steel, Cobalt Alloy 6, tungsten carbide, and ceramics are commonly used in applications where abrasive fluids are sprayed.

**Cost.** There are exceptions, but materials can generally be ranked

in the following order in terms of cost (from lowest to highest): brass, cast iron, plastics, stainless steels, cobalt-base alloys, nickel-base alloys, ceramics, refractory metals and precious metals.

Material Description	BETE Material No. (MN)	(DIN) Description	Temp. Rating (° C)	Trade Name*
Brass	4	Messing	230°	
Naval Brass	64		400°	
Bronze		Bronze	400°	
L.C. Steel	72	C-Stahl	210°	
303	5	1.4305	430°	
304	6	1.4301	430°	
304L		1.4306	430°	
316	7	1.4401	430°	
Tungsten Carbide	7H			
Alumina	26			
316L	20	1.4404	430°	
317	21	1.4440	430°	
317L	22	1.4438	430°	
416	24	1.4005	430°	
904L	74	1.4539	430°	
Alloy 20	70	2.4660	490°	Carpenter® 20
Nickel Alloy M30C	37	2.4360/2.4366	540°	Monel®
Nickel Alloy 600	35	2.4816	1100°	Inconel® 600
Nickel Alloy 625	3B	2.4856	1100°	Inconel® 625
Nickel Alloy 800	33	1.4876	1010°	Incoloy® 800
Nickel Alloy 825	34	2.4858	1010°	Incoloy® 825
Nickel Alloy B	31	2.4800/2.4810	760°	Hastelloy® B w/2.5 Max. Co
Nickel Alloy G	32	2.4619	1100°	Hastelloy® G
Nickel Alloy G30	49	2.4603	1100°	Hastelloy® G30
Nickel Alloy C276	81	2.4819	1100°	Hastelloy® C276
Nickel Alloy C22	2A	2.4602	1100°	Hastelloy® C22
Nickel	38	Nickel	350°	
Titanium	11	Titan	540°	
Tantalum	40	Tantal	1500°	
Zirconium	61	Zirkonium	540°	
Cobalt Alloy 6	9		1050°	Stellite® 6
SNBSC ceramic	62		1660°	Refrax®
RBSC ceramic	59		1380°	
PTFE	3	PTFE	150°	Teflon®
PVDF	36	PVDF	120°	Kynar®
PVC	1	PVC	60°	
CPVC	16	CPVC	100°	
Polypropylene	2	Polypropylen	70°	
UHMW	17		80°	
Polyurethane	69		80°	
ABS	15		70°	

The following are registered trademarks: Teflon®, Viton® (E.I. DuPont de Nemours & Co.); Hastelloy® (Haynes International, Inc.); Incoloy®, Monel® (The International Nickel Company, Inc.); Inconel® (Inco Nickel Sales, Inc.); Kynar® (Penwalt Corporation); REFRAX® (Carborundum Company); and Stellite® (Stoody Deloro Stellite, Inc.); M&M (Mars, Inc.) The BETE logo and MaxiPass are registered trademarks of BETE Fog Nozzle, Inc. ©BETE Fog Nozzle, Inc.

\* BETE does not represent that it manufactures its products with materials sold under any of these brand names. Customers sometimes ask for BETE products without using a USA standard specification for the material they require. When materials are described incompletely, with DIN specifications or with a commonly used brand name, BETE will usually supply materials according to the USA specifications listed above. Specifications for forms other than cast or bar may differ from the above.

# Since 1950 BETE has put nozzles into deep sea, deep space, and everywhere in between.

BETE's mission goes far beyond just selling nozzles: it is to provide spraying solutions that meet or exceed customer expectations in every detail. Extensive in-house capabilities—from CAD design through pattern testing—make it possible to offer the highest level of quality control throughout every phase



of production while providing the most responsive customer service in the industry. BETE nozzles provide life-saving fire protection on offshore oil rigs, clean compact disk masters between platings, cool off the hogs down on the farm, reduce SO<sub>2</sub> emissions at coal-fired generating stations, and even spray relish into huge mixing vats at food processing plants. Virtually every business uses nozzles—in equipment,

*Nozzles may be a rather small component of major systems. But they are absolutely critical to performance and efficiency.*

manufacturing or fire protection.

Their spray droplets can neutralize micron size pollutants, extinguish fires, cool hot gases, coat delicate electronic components, and much more.

BETE is a pioneer in all areas of nozzle manufacturing. The company was formed to produce John Bete's unique spiral (corkscrew) nozzle which can deliver a fine, high velocity spray at the lowest possible pressure.

Later, BETE developed the industry's leading clog-resistant design: the MaxiPass® full cone whirl nozzle, which boasts the maximum free passage possible.

More recently, BETE developed the SpiralAir® series of air atomizing nozzles which use compressed air or steam to convert large volumes of liquid into a finely atomized fog.

In each case, these



innovations have provided solutions to performance problems encountered with traditional nozzle designs. In fact, if there's one hallmark to The BETE Difference it's the ability to respond quickly and effectively to any kind of spraying challenge—whether simple or complex—anywhere in the world. BETE Applications Engineers will put their years of experience to work helping to determine the best way to provide the spray coverage and performance you need.



John Bete started the company in 1950 in a basement machine shop.

Innovative BETE nozzles have made the company a worldwide leader in the pollution control industry.

The first shower in space was taken by a U.S. astronaut using a special BETE nozzle.

The Spiral TFXP and MaxiPass are the industry's two leading clog-resistant designs.

# BETE is the only nozzle manufacturer with a complete in-house investment casting foundry.

It takes eight minutes to heat 60 lbs. of stainless steel to the 2900°F required for casting.

BETE pioneered the use of many nozzle materials including PTFE and titanium.

Platinum is the most expensive material the company has ever used; every scrap was saved.

Traditional New England craftsmanship in a state-of-the-art manufacturing facility.

Computer terminals throughout the plant keep track of the status of your order.

Virtually any material that can be machined, cast or molded can be used to make a nozzle. The selection depends on the fluid being sprayed and operating conditions such as temperature, abrasiveness, and corrosiveness.

BETE has always taken advantage of the latest developments in materials technology to create the most efficient nozzles possible. In the late 1960s, the company began experimenting with nozzles made from the ceramic Silicon Nitride Bonded Silicon Carbide (SNBSC) because of its excellent corrosion and abrasion resistance. Later, BETE made the first nozzle out of the even stronger Reaction Bonded Silicon Carbide (RBSC); making the



production of ceramic spiral nozzles practical.

In the 1970s BETE pioneered the use of Cobalt Alloy 6, a cobalt-based alloy with excellent corrosion and abrasion resistance, and has led the way in the use of engineering plastics, particularly PTFE, in nozzle manufacture.

In 1977 BETE made a significant new production

commitment by setting up an in-house casting foundry. This established total control of quality and scheduling for orders requiring cast alloys such as Stainless Steel, Cobalt Alloy 6, and Nickel Alloy.

In the late '80s and early '90s BETE became one of the first foundries in the world to cast Nickel Alloy C-22®, a new chromium nickel-based alloy.

When evaluating various materials, it's important to consider the impact of nozzle life on plant efficiency.





# BETE can perform every procedure in-house – from casting to machining to assembly.



BETE can help you select the material for maximum effectiveness and operating life in your application.

BETE uses three basic manufacturing processes: injection molding, machining from bar stock, and investment casting. Injection molding is used for large quantities of nozzles made from plastics such as PVC, ABS and PVDF. Bar stock machining is often used for metal alloy and plastic

nozzles which have relatively simple shapes or are made in small quantities. Investment casting offers a precise and economical way to produce complex shapes in alloys that are difficult or expensive to machine.

In addition, BETE offers many specialized processes. The welding department, which is fully qualified to ASME B & PV Code Section IX, has made a specialty of joining

dissimilar metals. This makes it possible to design nozzles combining alloys having superior anti-abrasion or corrosion properties with those having excellent machinability or weldability. Other specialized processes include plasma spray coating, plating, heat treating, grinding, ceramic fabrication, and filament winding of FRP.



BETE also does contract testing of nozzles and spray systems for many customers.

Complete in-house design and manufacturing mean on-time delivery.

A small change in a droplet's size, shape, or speed can have a major impact on performance.

Computer terminals throughout the plant keep track of the status of your order.

BETE's advanced CIM (Computer Integrated Manufacturing) environment links CAD workstations, a CAM part programming system and CNC machine tools.

The computerized scheduling system sequences every step in the production process, constantly adjusting the loads at each workstation to maximize throughput. This makes it possible to manufacture any one of thousands of products within a short time, while providing reliable delivery forecasts.



# Spray Lances

INJECTORS QUILLS SPOOLS FABRICATIONS



BETE takes its ability to provide robust spray nozzles one step further to construct spray assembly fabrications that you can install for immediate use.

Refineries and chemical plants have counted on BETE for decades to supply complete fabricated assemblies, custom designed from the nozzle up. Starting with the process conditions, we recommend the most appropriate nozzle and then incorporate it into an assembly that meets all mechanical design criteria.

Custom Ring Header



BETE works to your requirements, from the most simple to the most complex. Incorporation of client specifications is routine for us as is design, fabrication, and inspection to Code requirements. All design and fabrication work is performed at the same facility, ensuring close coordination through all phases of the process to ensure all mechanical and performance requirements are met.

### Design Requirements

- ASME B31.3 and B31.1 NBEP
- Welding qualification to ASME B&PVC, Section IX
- Canadian Registration (CRN)
- NACE compliance

### Mechanical Inspections

- RT – Radiographic
- UT – Ultrasonic
- PT – Visible Dye Penetrant
- Hydrostatic
- Hardness
- PMI – Positive Material Identification

### Performance Inspections

- Flow
- Spray Angle
- Droplet Size
- Special Customer Requirements

## LANCES

### Drop-in solutions

Whether you call them lances, quills, or injectors, BETE is your source.

Why endure the time and hassle to source pipe, flanges, nozzles, and fittings separately and then coordinate fabrication and testing of the assembly when you can have BETE do it all for you in an ISO 9001-controlled shop environment.

Fabrications are BETE's specialty, from complex Code compliant fabrications to simple pipe and flange assemblies. By using BETE as a single source supplier, you can concentrate on your larger process details, knowing that our experience is working for you.

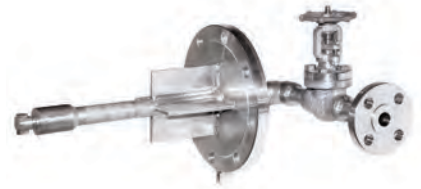

WTZ Lance with Inlet Valve and Gussets



Visit [www.spraylances.com](http://www.spraylances.com) for more information

[www.BETE.com](http://www.BETE.com)

TO ORDER: specify pipe size, connection type, nozzle number, spray angle, and material.



# RETRACTABLE LANCES

## Maintenance without downtime

Retractable lances allow you to remove a nozzle for inspection or service without taking your process offline. A retractable lance allows you to withdraw your nozzle, isolate it from the process, and then remove it completely for servicing all while maintaining the integrity of the process boundary. Once the nozzle is serviced or inspected, simply reattach it to the system, open the isolation valve, and insert it back into the process.

For smaller pipe sizes, retractable lances can be inserted and withdrawn manually. For larger sizes, or any size where automation or ease of use is required, BETE offers a robust retraction mechanism that effortlessly moves the lance. A simple cordless drill is all that is required to power the unit, making this design a favorite with maintenance crews. The mechanism is flexible in its configuration, allowing alternate electric, pneumatic, or hydraulic power sources to drive the unit.

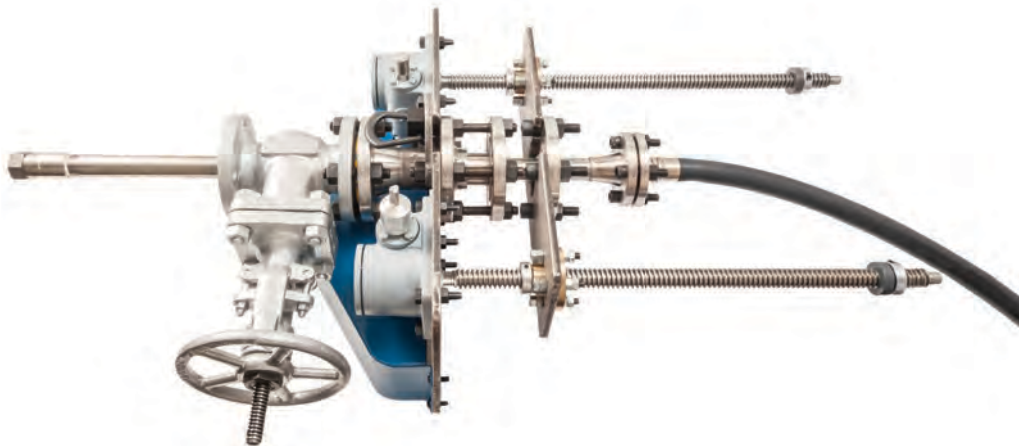
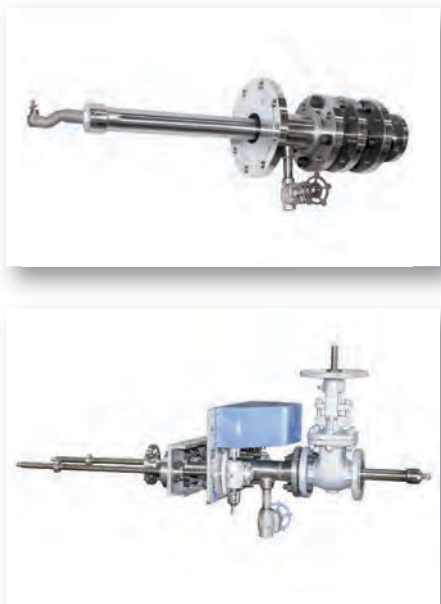

Complete retractable system including lance, isolation valve, and retraction mechanism

# SPOOL SECTIONS

## Complete spray solutions

Just as BETE can provide the lance on which the spray nozzle is installed, BETE can also provide the piping section into which the lance is installed. There are many benefits to single-sourcing all components related to the spray nozzle.

When all the work is done by one facility, there are no miscommunications between contractors about size, orientation, or location of the spray ports. The nozzles can be trial fit into the spool piece as part of the manufacturing process before leaving the factory. This translates to no last minute on-site surprises.

BETE provides everything you need from the concept design stage to on-site delivery, right down to the gaskets, studs, and nuts.

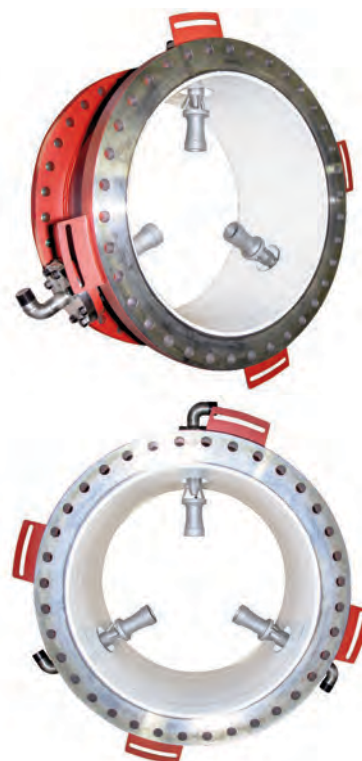

# Spray Engineering

BETE's extensive resources and more than 60 years of experience are available to help you with nozzle selection, solving existing spray problems, or designing a new nozzle or process. The spray engineering group is available on a contract basis and works with all of BETE's resources to help you design your process or solve your spray problem. At each stage of contracted Advanced Spray Engineering Services (ASES) we work with you to ensure we're solving the right problem within the given constraints. Our resources include:

## Physical Spray Laboratory Testing

For an engineering analysis we use our spray laboratory to evaluate the spray characteristics of a nozzle or process or to generate data for use in another analysis such as a CFD model. Spray characteristics like droplet size, spray angle, spray reach, and more can all be evaluated in the lab. In addition, we can evaluate hydrostatic integrity, reliability, and other essential nozzle characteristics not directly related to the spray. Noteworthy instrumentation includes:

- Patternator for measuring spray pattern
- BETE Model 700 Imaging Particle Analyzer
- TSI Phase-Doppler Particle Analyzer
- Integrated Data Acquisition Control System
- Containment Booth for alternative fluids
- Mechanical Inspection precision equipment

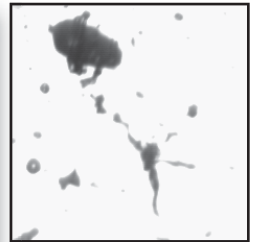

The BETE Droplet Analyzer is capable of characterizing non-spherical droplets like those seen in this actual image.

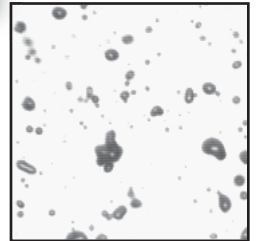

Actual droplet images captured using the BETE Model 700 Spray Analysis System.

## Physical Models

Sometimes there is no substitute for actually testing a nozzle in a process. It could be that the physics is too complicated to model or the desired result, such as an aesthetic effect, may be difficult to measure, or it might be necessary to validate a computer model. In these cases we can build a model of the system and test it in the laboratory.

## Computer Modeling

BETE offers computer modeling of sprays and processes using ANSYS® FLUENT® computational fluid dynamics software (CFD).

Modeling of a spray process can be very helpful in selecting nozzles, operating conditions, and mounting locations when initially designing a process especially if the process is not amenable to physical testing. It can also help find the cause of problems in an existing operation.

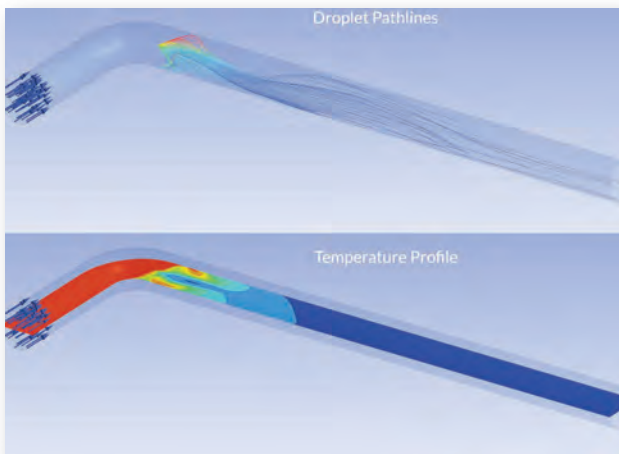

Are you ready to see how BETE's Advanced Spray Engineering can help? Tell us what you need by contacting Daniel deLesdernier: [ddel@bete.com](mailto:ddel@bete.com). We'll get back to you with an outline of what we can do for you.

While as a matter of course we maintain confidentiality, we are always willing to negotiate special confidentiality agreements if necessary.

## Manufacturing

The manufacturing facility is only few steps away from the lab so when a goal of the engineering work is a piece of hardware we collaborate with our manufacturing and design groups throughout the analysis process to ensure that the result is manufacturable and cost-effective. The manufacturing group also is available to help build test nozzles and fixtures from nozzles with microscopic orifices to multi-ton fabrications.

## Design of Experiments

When the number of variables in an experiment is large, careful selection of combinations of test conditions can reduce the amount of testing needed. BETE works with JMP statistical analysis software to assist with experimental design and data analysis.



# Spray Systems

Leveraging decades of experience with advanced engineering and manufacturing resources, BETE has grown far beyond just spray nozzles and today we offer a one-stop shop for complete spray system solutions.

Visit [www.bete.com/spray-systems](http://www.bete.com/spray-systems) for a video demo and more information.

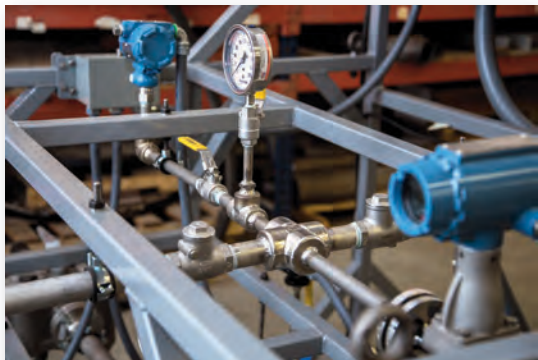

Exhaust Gas Cooling System



Aluminum Plate Quench System



## The Whole Package

When it comes to providing high quality spray performance for your process, selection of an appropriate spray nozzle model is only the first step in successful implementation. Just as critical as spray nozzle selection is the engineering of upstream flow control equipment, such as pump and flow control skids, to ensure that nozzles are supplied with the proper fluid conditions to function as intended.

BETE's deep understanding of spray nozzle and fluid system performance allows us to design and build custom-tailored flow control systems that meet the specific needs of your spray process. Alternatively, if you have an existing spray system that does not perform as desired, we can evaluate your system and recommend changes to improve the performance and reliability of your spray process. Using a variety of engineering resources, we evaluate pressure losses caused by pipe friction, elevation, and valve or instrument flow coefficients. We then adjust pump and nozzle performance curves accordingly to make sure that your system will operate exactly the way you need it to.

For spray processes that require automation, our engineers have experience with a variety of controls options that can make spray parameter adjustments based on real-time process signals and feedback loops. These spray systems can operate as stand-alone units or further integrate with central plant control systems for remote monitoring and control input.

## Our engineered systems may include any or all of the following components:

- Nozzles/lances
- Piping/tubing/fittings
- Valves
- Pressure regulators
- Strainers/filters
- Solenoids
- Pumps/motors
- Automatic control valves
- Pressure/temperature/flow sensors
- Variable Frequency Drives (VFDs)
- Programmable Logic Controllers (PLC)
- Switches, relays, and other electrical hardware
- Structural skid frames

## Complete Spray System Solutions

From process engineering and nozzle selection assistance all the way to implementation of automated spray systems, contact us today to see how we can help you increase the performance, reliability, efficiency, and profitability of your spray process.

# FlexFlow™

## FLEXFLOW PRECISION SPRAY CONTROL SYSTEMS FOR AUTOMATIC SPRAY NOZZLES

BETE's FlexFlow Spray Systems ensure precision control and flexible automation for our Electric HydroPulse® and other automatic spray nozzles. These plug-and-play controllers are an elegant solution for precision coating, moistening, and lubricating applications.

Consider the FlexFlow for any industrial process where expensive compounds or ingredients need to be sprayed directly onto the process target. Each control panel can be used as a standalone system – or upgrade to the 2000 model to integrate with your existing plant operations. Discover optimal spray performance for applying flavorings, coatings, mold inhibitors, antimicrobials, preservatives, release agents, and moisturizers with exceptional accuracy.



### FLEXFLOW™ 1000

- HMI touch screen includes intuitive operations for streamlined control and diagnostic overview for troubleshooting
- Operate up to 12 nozzles
- Two zones of precision control
  - Operate up to 6 nozzles in each zone
  - Zones 1 and 2 can be programmed with independent or synchronous settings



### FLEXFLOW™ 2000

The FlexFlow 2000 offers ultimate system flexibility by managing up to 20 spray nozzles in up to 20 independently controlled spray zones. With individual spray zone assignment for each nozzle, you can group nozzles into as many zones as needed to accomplish your spray process objectives.

- HMI touch screen includes intuitive operations for streamlined control and diagnostic overview for troubleshooting
- Match spray volume to conveyor speed with auto-adjust duty cycle
- Extremely flexible in zone operations – can operate up to 20 nozzles with up to 20 triggers in up to 20 zones
- Ethernet port for process integration
- Three versions available with an easy upgrade path:
  - Model 2010 operates up to 10 nozzles
  - Model 2016 operates up to 16 nozzles
  - Model 2020 operates up to 20 nozzles

# COMPATIBLE AUTOMATIC SPRAY NOZZLES

## HYDROPULSE® - ELECTRIC - EHP - FOOD GRADE HYGIENIC

<b>Liquid inlet connection</b>	1/8", NPT or BSPP; or 1/2" Tri-clamp
<b>Maximum liquid flow rate</b>	1.0 GPM / 3.8 LPM
<b>Maximum rated pressure</b>	250 PSI / 17 bar
<b>Thermal insulation class</b>	F (155°C / 311°F)
<b>Power</b>	9.3W @ 24VDC
<b>Electrical Connector</b>	M8 3-pin
<b>Maximum cycle frequency</b>	150 cycles/sec
<b>Nozzle construction</b>	Stainless steel wetted components, Food grade Viton® (FKM) seals, hygienic design
<b>Interchangeable BJ, BJH, and CW nozzle tip options.</b>	



## HYDROPULSE® - ELECTRIC - EHPI - INDUSTRIAL DESIGN

<b>Liquid inlet connection</b>	1/8", NPT or BSPP
<b>Maximum liquid flow rate</b>	1.0 GPM / 3.8 LPM
<b>Maximum rated pressure</b>	300 PSI / 20 bar
<b>Thermal insulation class</b>	F (155°C / 311°F)
<b>Power</b>	10.4W @ 24VDC
<b>Electrical Connector</b>	DIN 11mm
<b>Maximum cycle frequency</b>	50 cycles/sec
<b>Nozzle construction</b>	Stainless steel wetted components, Viton® (FKM) seals
<b>Interchangeable BJ, BJH, and CW nozzle tip options.</b>	



## BENEFITS

- Precision volume sprays directly on the target
- Reduced waste and minimal over spray maintains a clean, safe environment
- Uniform and repeatable coverage improves product consistency
- Each nozzle provides a wide range of flow rates





# FEATURES AND UPGRADES

The BETE FlexFlow™ spray controllers are standalone electrical control panels intended to provide user-friendly control of BETE Electric HydroPulse (EHP/EHPI) series electric-actuated spray nozzles.



A Siemens brand Programmable Logic Controller (PLC) and associated hardware operates the nozzles. Spray zones can be triggered manually or they can be triggered automatically using digital inputs from process sensors. User-adjustable signal delays provide the most accurate spray timing functionality.

The spray flow rate can also be electronically controlled by pulsing the sprays while adjusting the ratio of ON versus OFF dwell time within each cycle. Pulsing at high frequency allows the average flow rate to be adjusted while maintaining constant fluid supply pressure and the appearance of continuous, uniform coverage. This flow control process is known as Pulse Width Modulation (PWM).

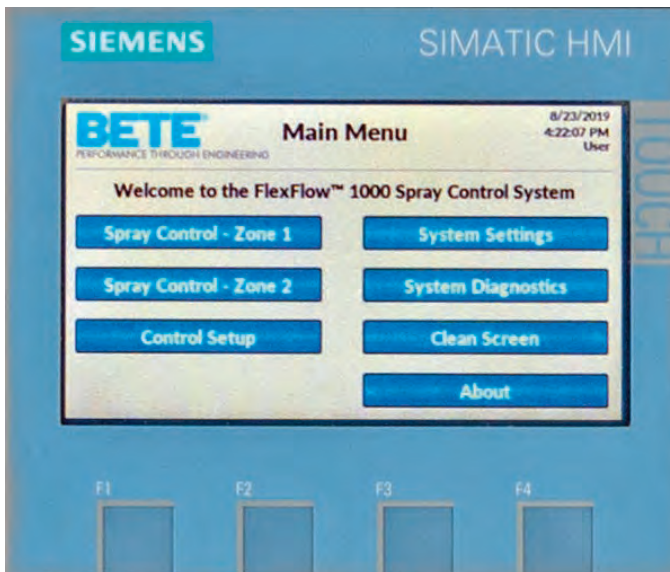
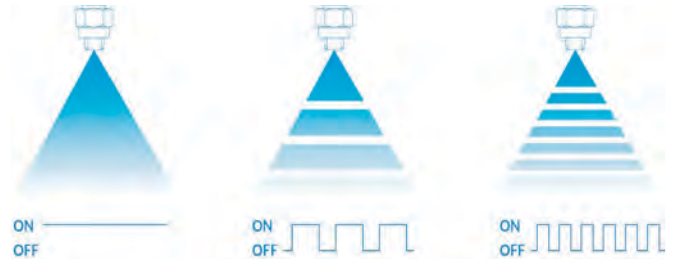

A touchscreen Human Machine Interface (HMI) allows users to configure the spray system and adjust spray parameters through an easy-to-navigate menu of options. Adjustable parameters for each spray zone include nozzle cycle rate, duty cycle, trigger signal delays, and trigger state.

TO ORDER: specify pipe size, connection type, nozzle number, spray angle, and material.



# FEATURES AND UPGRADES



A cable gland plate comes standard with every FlexFlow control panel. Only pierce as many openings as needed through the membrane for easy access to field wiring.



The FlexFlow 2000 includes an Ethernet port for process integration with your existing plant operations.



A hygienic enclosure upgrade is available for any FlexFlow System.

Hygienic enclosures feature special crevice-free door seals and hardware to eliminate product buildup. An angled roof design prevents objects from being deposited on top of the enclosure and also allows fluids to drain off rapidly. Door hinges are installed inside of the sealing zone leaving the outside exceptionally easy to clean and optional wall spacers create space for easy cleaning behind the enclosure.



Hygienic enclosure wall-mounts are an available upgrade add-on. These standoffs are an optional accessory for hygienic enclosures to provide access for cleaning in the space between the back of the panel and a wall.

# HydroPulse®

Food Grade Hygienic Design/ EHP and Industrial Design/ EHPI

## DESIGN FEATURES

- Interchangeable spray tips
- Electrically actuated for crisp on/off spray
- Mounting brackets available
- EHP features straight through porting for in-series set-up

## SPRAY CHARACTERISTICS

- Precision volume sprays directly on the target
- Reduced waste and minimal overspray maintain a clean, safe environment
- Uniform and repeatable coverage improves product consistency

**Spray pattern:** Spray Patterns: Flat Fan, Full Cone, Hollow Cone

**Spray angles:** 0° to 120°

**Flow rate:** 0.038 to 3.8 L/min



AUTOMATIC

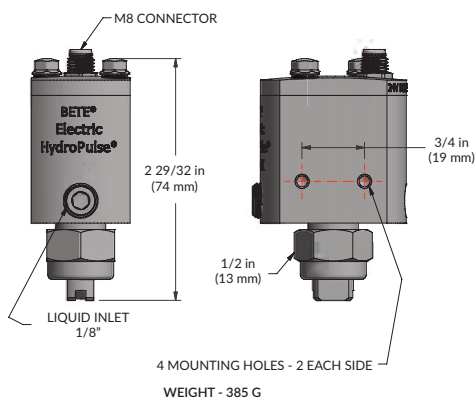
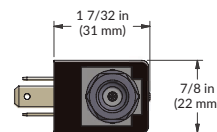
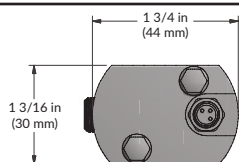

WEIGHT - 385 G

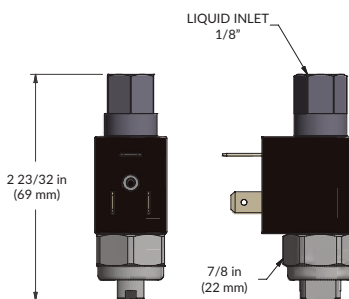

WEIGHT - 115 G

## Flow Rates of BJ (Fan) Tips on EHP and EHPI Bodies, L/min\*



0°, 15°, 25°, 40°, 50°, 65°, 80°, 95°, 110° Spray Angles, Standard Materials 303 and 316 Stainless Steel

	Nozzle Inlet Pressure, bar							
	0.3	0.5	1	2	3	5	10	15
**BJ0067	0.083	0.11	0.15	0.21	0.26	0.34	0.49	0.61
BJ01	0.12	0.16	0.22	0.31	0.38	0.49	0.72	0.87
BJ015	0.18	0.23	0.33	0.45	0.57	0.76	1.1	1.3
BJ02	0.23	0.3	0.42	0.61	0.76	0.98	1.4	1.7
BJ03	0.34	0.45	0.61	0.87	1.1	1.4	2	2.5
BJ04	0.42	0.57	0.79	1.1	1.4	1.8	2.5	3.1
BJ05	0.53	0.68	0.95	1.3	1.6	2	2.9	3.5
BJ06	0.61	0.76	1.1	1.5	1.8	2.3	3.2	3.8
BJ08	0.72	0.91	1.2	1.7	2	2.6	3.6	
BJ10	0.79	0.98	1.4	1.9	2.2	2.8	3.8	
BJ15	0.95	1.1	1.5	2	2.4	3	3.8	
BJ20	0.98	1.2	1.6	2.1	2.5	3.1		
BJ30	1.1	1.3	1.7	2.2	2.6	3.1		

\*\*Only available in angles up to and including 65°

TO ORDER: specify pipe size, connection type, nozzle number, spray angle, and material.

**Flow Rates of CW (Full or Hollow Cone) Tips on EHP and EHPI Bodies, L/min\***  
 80° and 120° Spray Angles, Standard Materials 303 and 316 Stainless Steel

	Nozzle Inlet Pressure, bar							
	0.3	0.5	1	2	3	5	10	15
								
CW-25F	0.31	0.38	0.53	0.76	0.91	1.2	1.7	2
CW-50F	0.53	0.68	0.95	1.3	1.6	2	2.8	3.4
CW-75F	0.72	0.91	1.2	1.7	2	2.6	3.5	
CW-100F	0.83	1	1.4	1.9	2.2	2.8	3.8	
								
CW-25H	0.31	0.38	0.53	0.76	0.91	1.2	1.7	2
CW-50H	0.53	0.68	0.95	1.3	1.6	2	2.8	3.4
CW-75H	0.72	0.91	1.2	1.7	2	2.6	3.5	
CW-100H	0.83	1	1.4	1.9	2.2	2.8	3.8	



AUTOMATIC

**Flow Rates of BJH (Fan) Tips on EHP and EHPI Bodies, L/min\***

5° to 120° Spray Angles, Tungsten Carbide Insert with 303 Stainless Steel Housing

	Nozzle Inlet Pressure, bar				
	2	3	5	10	15
					
BJH-0.18			0.038	0.057	0.068
BJH-0.28			0.098	0.14	0.17
BJH-0.38			0.18	0.25	0.31
BJH-0.45	0.16	0.19	0.25	0.35	0.42
BJH-0.53	0.21	0.26	0.33	0.45	0.57
BJH-0.66	0.33	0.42	0.53	0.72	0.91
BJH-0.78	0.45	0.57	0.72	1	1.2
BJH-0.89	0.57	0.72	0.91	1.3	1.6
BJH-0.99	0.72	0.87	1.1	1.6	2
BJH-1.14	0.95	1.1	1.5	2	2.5
BJH-1.29	1.1	1.4	1.8	2.5	3
BJH-1.45	1.4	1.7	2.1	2.9	3.5
BJH-1.60	1.5	1.9	2.3	3.2	3.8
BJH-1.80	1.7	2	2.6	3.5	
BJH-1.91	1.8	2.2	2.7	3.7	



*Tungsten carbide orifice inserts for maximum wear resistance and service life.*

\* Maximum flows shown above. Flow rates can be turned down to 5% of listed value using PWM (Pulse Width Modulation). Contact BETE for details.

CALL 413-772-0846  
 Call for the name of your nearest BETE representative.

# HydroPulse®

PHP - Pneumatically Actuated - BJ & BJH Flat Fan - CW Full/Hollow Cone - ST Full Cone

## DESIGN FEATURES

- Interchangeable spray tips
- Pneumatically actuated for crisp on/off spray
- Mounting brackets available
- Straight through porting for in-series set-up

## SPRAY CHARACTERISTICS

- Precision volume sprays directly on the target
- Reduced waste and minimal overspray maintain a clean, safe environment
- Uniform and repeatable coverage improves product consistency

**Spray pattern:** Flat Fan, Full Cone, Hollow Cone

**Spray angles:** 0° to 120°

**Flow rate:** 0.048 to 57.7 L/min



AUTOMATIC

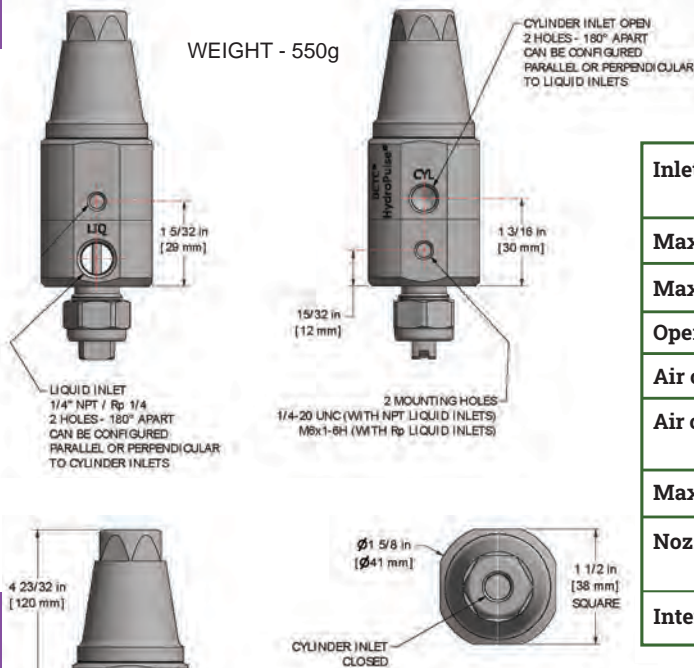

<b>Inlet connections</b>	¼" NPT or BSPP, liquid; ⅝" NPT or BSPP, cylinder air; ½" or DN10 tri-clamp
<b>Maximum flow rate</b>	57.7 LPM
<b>Maximum rated liquid pressure</b>	42 bar
<b>Operating temperature range</b>	-26°C to 204°C
<b>Air cylinder pressure</b>	2 bar to 17 bar
<b>Air cylinder operation</b>	Single acting (spring return) or double acting.
<b>Maximum cycle frequency</b>	50 cycles/sec
<b>Nozzle construction</b>	Stainless steel wetted components Viton® (FKM) seals
<b>Interchangeable BJ, BJH, CW, and ST nozzle tip options.</b>	

## CW Flow Rates and Dimensions

Full Cone and Hollow Cone, 80° and 120° Spray Angles

Nozzle Number	K Factor	LITERS PER MINUTE @ BAR								Approx. Orifice Dia.(mm)
		0.5 bar	0.7 bar	1 bar	2 bar	3 bar	5 bar	10 bar	15 bar	
<b>CW25</b>	0.587	0.424	0.497	0.587	0.814	0.984	1.25	1.73	2.10	1.14
<b>CW50</b>	1.17	0.848	0.993	1.17	1.63	1.97	2.50	3.47	4.19	1.37
<b>CW75</b>	1.76	1.27	1.49	1.76	2.44	2.95	3.75	5.20	6.29	1.60
<b>CW100</b>	2.35	1.70	1.99	2.35	3.25	3.94	5.01	6.93	8.39	2.18

$$\text{Flow Rate (l/min)} = K (\text{bar})^{0.47}$$

**Standard Materials: Brass, 303 Stainless Steel, and 316 Stainless Steel.**

Spray angle performance varies with pressure. Contact BETE for specific data on critical applications.

TO ORDER: specify pipe size, connection type, nozzle number, spray angle, and material.



## ST Flow Rates and Dimensions

Full Cone, 90° (FCN) and 120° (FC) Spray Angles

Nozzle Number	K Factor	LITERS PER MINUTE @ BAR								Approx. (mm) Orifice Dia.
		0.5 bar	0.7 bar	1 bar	2 bar	3 bar	5 bar	10 bar	20 bar	
ST6	3.19	2.26	2.67	3.19	4.5	5.5	7.1	10.1	14.3	2.38
ST8	5.93	4.19	4.96	5.93	8.4	10.3	13.2	18.7	26.5	3.18
ST10	9.12	6.45	7.63	9.12	12.9	15.8	20.4	28.8	40.8	3.97

$$\text{Flow Rate (l/min)} = K \sqrt{\text{bar}}$$

Standard Materials: 316 Stainless, Cobalt Alloy 6

## BJ Flow Rates

Fan, 0°, 15°, 25°, 40°, 50°, 65°, 80°, 95°, 110° Spray Angles

	K Factor	Nozzle Inlet Pressure, bar								Equiv. Orifice Diameter (mm)	Standard Available Spray Angles*
		0.3	1	2	5	10	20	40			
BJ 0067	0.153	0.084	0.153	0.220	0.340	0.480	0.680	0.970	0.580	0, 15, 25, 40, 50, 65, 80	
BJ 01	0.228	0.120	0.228	0.320	0.510	0.720	1.02	1.44	0.710	0, 15, 25, 40, 50, 65, 80, 95, 110	
BJ 015	0.342	0.190	0.342	0.480	0.760	1.08	1.53	2.16	0.970	0, 15, 25, 40, 50, 65, 80, 95, 110	
BJ 02	0.456	0.250	0.456	0.640	1.02	1.44	2.04	2.88	0.990	0, 15, 25, 40, 50, 65, 80, 95, 110	
BJ 03	0.684	0.370	0.684	0.970	1.53	2.16	3.06	4.32	1.19	0, 15, 25, 40, 50, 65, 80, 95, 110	
BJ 04	0.912	0.500	0.912	1.29	2.04	2.88	4.08	5.77	1.40	0, 15, 25, 40, 50, 65, 80, 95, 110	
BJ 05	1.14	0.620	1.14	1.61	2.55	3.60	5.10	7.21	1.55	0, 15, 25, 40, 50, 65, 80, 95, 110	
BJ 06	1.37	0.750	1.37	1.93	3.06	4.32	6.11	8.65	1.70	0, 15, 25, 40, 50, 65, 80, 95, 110	
BJ 08	1.82	1.00	1.82	2.58	4.08	5.77	8.15	11.5	1.88	0, 15, 25, 40, 50, 65, 80, 95, 110	
BJ 10	2.28	1.25	2.28	3.22	5.10	7.21	10.2	14.4	2.18	0, 15, 25, 40, 50, 65, 80, 95, 110	
BJ 15	3.42	1.87	3.42	4.83	7.64	10.8	15.3	21.6	2.72	0, 15, 25, 40, 50, 65, 80, 95, 110	
BJ 20	4.56	2.5	4.56	6.45	10.2	14.4	20.4	28.8	3.18	0, 15, 25, 40, 50, 65, 80, 95, 110	
BJ 30	6.84	3.74	6.84	9.67	15.3	21.6	30.6	43.2	3.67	0, 15, 25, 40, 50, 65, 80, 95, 110	
BJ 40	9.12	4.99	9.12	12.9	20.4	28.8	40.8	57.7	3.97	0, 15, 25, 40, 50, 65, 80, 95, 110	

$$\text{Flow Rate (l/min)} = K \sqrt{\text{bar}}$$

BJ tip materials: Brass, 303SS, 316SS

## BJH Flow Rates and Dimensions

5° to 120° Spray Angles, Tungsten Carbide Insert with 303 Stainless Steel Housing

	K Factor	LITERS PER MINUTE @ BAR						Equivalent Orifice Dia. (mm)	Available Spray Angles
		2 bar	3 bar	4 bar	7 bar	30 bar			
BJH-0.18	0.018	-	-	-	0.048	0.099	0.18	5°, 10°, 15°, 20°, 25°, 30°, 33°, 40°, 50°	
BJH-0.28	0.043	-	-	-	0.114	0.236	0.28	5°, 10°, 20°, 33°, 40°, 50°, 65°, 73°	
BJH-0.38	0.079	-	-	-	0.209	0.433	0.38	10°, 20°, 33°, 40°, 50°, 65°, 73°, 80°, 90°, 100°	
BJH-0.45	0.110	-	-	-	0.291	0.602	0.45	10°, 20°, 33°, 40°, 50°, 65°, 73°, 80°, 90°, 100°, 110°, 120°	
BJH-0.53	0.152	0.215	0.263	0.304	0.402	0.833	0.53	100°, 110°, 120°	
BJH-0.66	0.237	0.335	0.410	0.474	0.627	1.30	0.66		
BJH-0.78	0.330	0.467	0.572	0.660	0.873	1.81	0.78	10°, 20°, 33°, 40°, 50°, 65°, 73°, 80°, 90°, 100°, 110°, 120°	
BJH-0.89	0.430	0.608	0.745	0.860	1.14	2.36	0.89		
BJH-0.99	0.532	0.752	0.921	1.06	1.41	2.91	0.99		
BJH-1.14	0.706	0.998	1.22	1.41	1.87	3.87	1.14	20°, 33°, 40°, 50°, 65°, 73°, 80°, 90°, 100°, 110°, 120°	
BJH-1.29	0.904	1.28	1.57	1.81	2.39	4.95	1.29		
BJH-1.45	1.14	1.61	1.97	2.28	3.02	6.24	1.45	20°, 33°, 40°, 50°, 65°, 73°, 80°, 90°, 100°, 110°	
BJH-1.60	1.39	1.97	2.41	2.78	3.68	7.61	1.60	20°, 33°, 40°, 50°, 65°, 73°, 80°, 90°, 100°	
BJH-1.80	1.76	2.49	3.05	3.52	4.66	9.64	1.80	20°, 33°, 40°, 50°, 65°, 73°, 80°, 90°	
BJH-1.91	1.98	2.80	3.43	3.96	5.24	10.8	1.91	20°, 33°, 40°, 50°, 65°, 73°, 80°	

$$\text{Flow Rate (l/min)} = K \sqrt{\text{bar}}$$

Standard Materials: Tungsten Carbide Insert with 303 Stainless Steel Housing

Spray angle performance varies with pressure. Contact BETE for specific data on critical applications.

AUTOMATIC

CALL 413-772-0846  
Call for the name of your nearest BETE representative.



# TF

## Wide Range of Flows and Angles

### DESIGN FEATURES

- The original spiral nozzle invented by BETE and continuously improved!
- High energy efficiency
- One-piece/no internal parts
- Clog-resistant performance
- High discharge velocity
- Male connection standard; female connection available by special order

### SPRAY CHARACTERISTICS

- Wide range of flow rates and spray angles
- Fine atomization

**Spray patterns:** Full Cone.

For Hollow Cone, see page 53

**Spray angles:** 50° to 180°

**Flow rates:** 2.26 to 10700 l/min  
(Higher flow rates available)

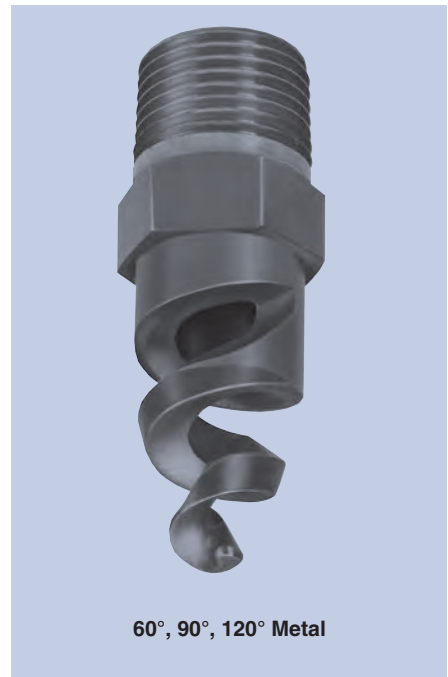

60°, 90°, 120° Metal

Available with FM approval: N series (page 114), 1/4" TF8 NN, FCN in brass, 1/2" TF24-150 in multiple materials

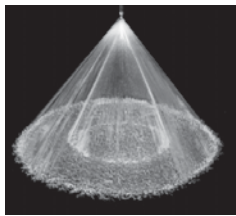

Full Cone 60° (NN)

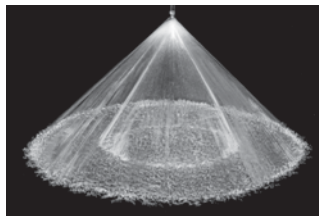

Full Cone 90° (FCN)

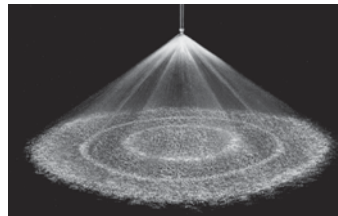

Full Cone 150°/170°

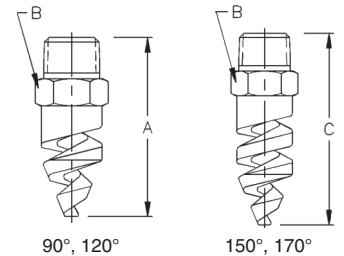

Dimensions are approximate. Check with BETE for critical dimension applications

### TF Full Cone Flow Rates and Dimensions

Full Cone, 60° (NN), 90° (FCN or FFCN), 120° (FC or FFC), 150° and 170° Spray Angles, 1/8" to 4" Pipe Sizes, BSP or NPT

Male Pipe Size	Nozzle Number	Available Spray Angles 60° 90° 120° 150° 170°	K Factor	LITERS PER MINUTE @ BAR							PTFE not recommended at pressures above red line Metal ONLY at pressures above green line			Approx. (mm)		Dim. (mm) for Metal Only*			Wt. (g)	
				0.5 bar	0.7 bar	1 bar	2 bar	3 bar	5 bar	10 bar	20 bar	Orif. Dia.	Free Pass Dia.	A	B	C	60° 90° Metal	120° Metal Plas.		
1/8	TF6	60° 90° 120° 150° 170°	3.19	2.26	2.67	3.19	4.5	5.5	7.1	10.1	14.3	2.38	2.38	42.9	14.3	42.9	28	6		
	TF8	60° 90° 120° 150° 170°	5.93	4.19	4.96	5.93	8.4	10.3	13.2	18.7	26.5	3.18	3.18	42.9	14.3	55.6				
1/4	TF6	60° 90° 120° 150° 170°	3.19	2.26	2.67	3.19	4.5	5.5	7.1	10.1	14.3	2.38	2.38	47.6	14.3	47.6	35	6		
	TF8	60° 90° 120° 150° 170°	5.93	4.19	4.96	5.93	8.4	10.3	13.2	18.7	26.5	3.18	3.18	47.6	14.3	60.3				
	TF10	60° 90° 120° 150° 170°	9.12	6.45	7.63	9.12	12.9	15.8	20.4	28.8	40.8	3.97	3.18	47.6	14.3	60.3				
3/8	TF6	60° 90° 120°	3.19	2.26	2.67	3.19	4.5	5.5	7.1	10.1	14.3	2.38	2.38	47.6	17.5	60.5	46	7		
	TF8	60° 90° 120°	5.93	4.19	4.96	5.93	8.4	10.3	13.2	18.7	26.5	3.18	3.18							
	TF10	60° 90° 120°	9.12	6.45	7.63	9.12	12.9	15.8	20.4	28.8	40.8	3.97	3.18							
	TF12	60° 90° 120° 150° 170°	13.7	9.67	11.4	13.7	19.3	23.7	30.6	43.2	61.1	4.76	3.18							
	TF14	60° 90° 120° 150° 170°	18.5	13.1	15.4	18.5	26.1	32.0	41.3	58.4	82.6	5.56	3.18							
	TF16	60° 90° 120° 150° 170°	24.2	17.1	20.2	24.2	34.2	41.8	54.0	76.4	108	6.35	3.18							
1/2	TF24	60° 90° 120° 150° 170°	54.9	38.8	46.0	54.9	77.7	95.1	123	174	246	9.53	4.76	63.5	22.2	77.7	85	14		
	TF28	60° 90° 120° 150° 170°	75.2	53.2	62.9	75.2	106	130	168	238	336	11.1	4.76							
3/4	TF32	60° 90° 120° 150° 170°	95.7	67.7	80.1	95.7	135	166	214	303	428	12.7	4.76	69.9	28.6	88.9	156	25		
1	TF40	60° 90° 120° 150° 170°	153	108	128	153	216	264	341	483	683	15.9	6.35	92.1	34.9	111	241	71		
	TF48	60° 90° 120° 150° 170°	217	153	181	216	306	375	484	685	968	19.1	6.35							
1 1/2	TF56	60° 90° 120° 150° 170°	294	208	246	294	416	509	657	930	1320	22.2	7.94	111	50.8	137	624	120		
	TF64	60° 90° 120° 150° 170°	385	272	322	385	545	667	861	1220	1720	25.4	7.94							
	TF72	60° 90° 120° 150° 170°	438	309	366	438	619	758	978	1380	1960	28.6	7.94							
2	TF88	60° 90° 120° 150° 170°	638	451	534	638	902	1110	1430	2020	2850	34.9	11.1	143	63.5	175	1300	227		
	TF96 <sup>1</sup>	60° 90° 120° 150° 170°	806	570	674	806	1140	1400	1800	2550	3600	38.1	11.1						176	63.5
3	TF112 <sup>1</sup>	60° 90° 120° 150° 170°	1170	825	976	1170	1650	2020	2610	3690	5220	44.5	14.3	219	88.9	235	3230	567		
	TF128 <sup>1</sup>	60° 90° 120° 150° 170°	1550	1090	1290	1550	2190	2680	3460	4891	6920	50.8	14.3							
4	TF160 <sup>1</sup>	60° 90° 120°	2390	1690	2000	2390	3380	4140	5350	7570	10700	63.5	15.9	257	114		4790	765		

Flow Rate (l/min) = K √bar \*Dimensions are for bar stock, cast sizes may vary. \*\*60° nozzles slightly longer; call BETE for details <sup>1</sup>Three turn nozzles

Standard Materials: Brass, 316 Stainless Steel, PVC, Polypropylene, and PTFE (Poly. not available for TF6 thru TF10).

Spray angle performance varies with pressure. Contact BETE for specific data on critical applications.

TO ORDER: specify pipe size, connection type, nozzle number, spray angle, and material.

# TFXP

## Largest Free Passage

### DESIGN FEATURES

- Largest free passage in the original spiral nozzle invented by BETE and continuously improved!
- Passes particles equal to orifice size
- Clog-resistant
- One-piece, extra-heavy construction
- High energy efficiency
- Male connection

### SPRAY CHARACTERISTICS

- Wide range of flow rates
  - Fine atomization
- Spray pattern:** Full Cone  
(Hollow Cone available by special order)
- Spray angles:** 90° and 120°
- Flow rates:** 9.67 to 10700 l/min

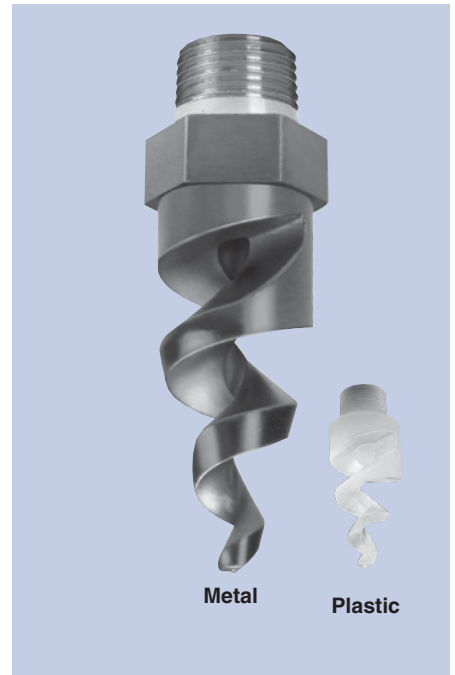

FULL CONE

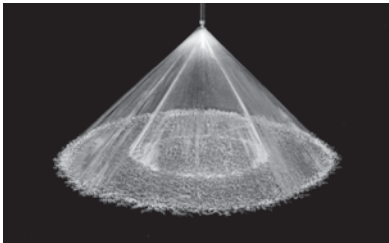

Full Cone 90° (XPN)

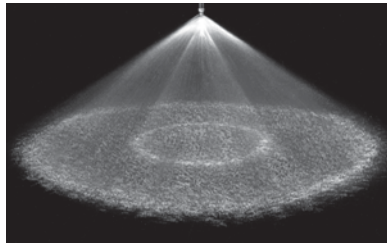

Full Cone 120° (XP)

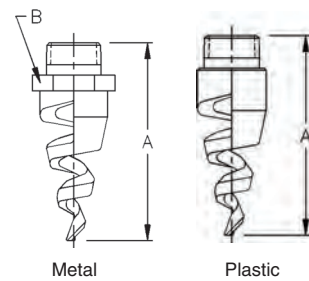

Metal

Plastic

Dimensions are approximate. Check with BETE for critical dimension applications.

### TFXP Flow Rates and Dimensions

Full Cone, 90° (XPN) and 120° (XP) Spray Angles, 3/8" to 4" Pipe Sizes, BSP or NPT

Male Pipe Size	Nozzle Number	K Factor	LITERS PER MINUTE @ BAR							PTFE not recommended at pressures above red line Metal ONLY at pressures above green line			Approx. Free Pass. & Orifice Dia. (mm)	Approximate Dimensions (mm) For Metal Only		Wt. (kg) Metal Plas.	
			0.5 bar	0.7 bar	1 bar	2 bar	3 bar	5 bar	10 bar	20 bar	A	B		Metal	Plas.		
3/8	TF12	13.7	9.67	11.4	13.7	19.3	23.7	30.6	43.2	61.1	4.76	73.1	22.2	0.09	0.02		
	TF14	18.5	13.1	15.4	18.5	26.1	32.0	41.3	58.4	82.6	5.56	73.1	22.2				
	TF16	24.2	17.1	20.2	24.2	34.2	41.8	54.0	76.4	108	6.35	69.9	22.2				
	TF20	37.6	26.6	31.5	37.6	53.2	65.1	84.1	119	168	7.94	79.5	22.2				
1/2	TF24	54.9	38.8	46.0	54.9	77.7	95.1	123	174	246	9.53	88.1	26.9	0.19	0.03		
	TF28	75.2	53.2	62.9	75.2	106	130	168	238	336	11.1	88.9	26.9				
3/4	TF32	95.7	67.7	80.1	95.7	135	166	214	303	428	12.7	137	44.5	0.71	0.10		
1	TF40	153	108	128	153	216	264	341	483	683	15.9	133	50.8	0.71	0.11		
	TF48	216	153	181	216	306	375	484	685	968	19.1	168	50.8			0.93	0.21
1 1/2	TF56	294	208	246	294	416	509	657	930	1315	22.2	177	63.5	1.81	0.27		
	TF64	385	272	322	385	545	667	861	1220	1720	25.4	176	63.5			1.11	0.24
	TF72	438	309	366	438	619	758	978	1380	1960	28.6	188	63.5			1.27	0.24
2	TF88	638	451	534	638	902	1110	1430	2020	2850	34.9	267	76.2	2.32	0.57		
	TF96	806	570	674	806	1140	1400	1800	2550	3600	38.1	279	76.2			2.86	0.57
3	TF112	1167	825	976	1170	1650	2020	2610	3690	5220	44.5**	305	88.9	3.80	0.62		
	TF128	1547	1090	1290	1550	2190	2680	3460	4890	6920	50.8**	297	88.9			4.42	0.68
4	TF160	2393	1690	2000	2390	3380	4140	5350	7570	10700	63.5**	305	114	7.08	0.85		

Flow Rate ( $l/min$ ) =  $K \sqrt{bar}$       \*\*Free passage is 38.1 mm

Standard Materials: Brass, 316 Stainless Steel, PVC, Polypropylene, Cobalt Alloy 6, and PTFE.

Spray angle performance varies with pressure. Contact BETE for specific data on critical applications.

CALL 413-772-0846  
Call for the name of your nearest BETE representative.





# ST

## Abrasion-Resistant

### DESIGN FEATURES

- Cobalt Alloy 6 or RBSC ceramic parts in high-wear areas
- High energy efficiency
- No internal parts
- Clog-resistant
- Male and female connections
- Flanged and special connections available as required

### SPRAY CHARACTERISTICS

- Fine atomization
- Spray pattern:** Full Cone (Hollow Cone available by special order)
- Spray angles:** 90° and 120° standard
- Flow rates:** 2.26 to 10700 l/min (Higher flow rates available)

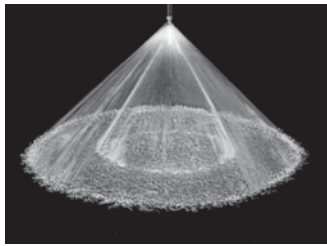
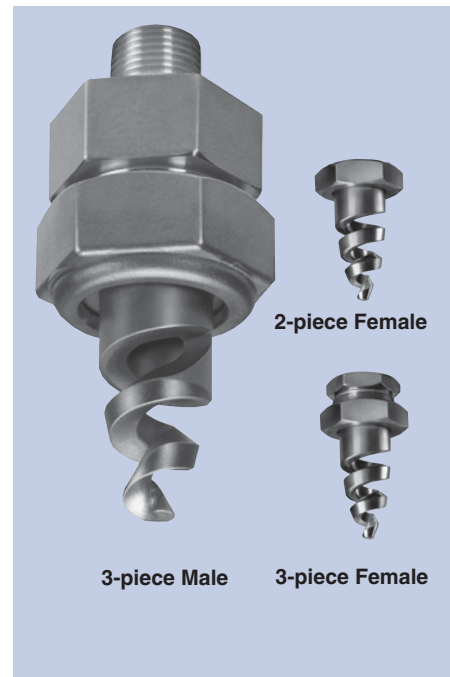

Full Cone 90° (FCN)

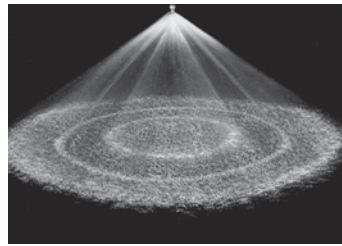

Full Cone 120° (FFC)

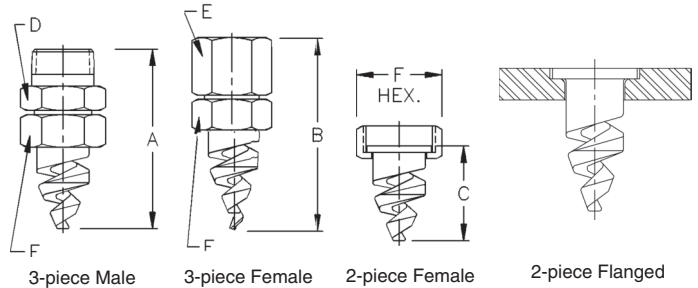

Dimensions are approximate. Check with BETE for critical dimension applications.

### ST Flow Rates and Dimensions

Full Cone, 90° (FCN or FFCN) and 120° (FC or FFC) Spray Angles, 1/4" to 4" Pipe Sizes, BSP or NPT

3 piece Male or Female Pipe Size	** 2 piece Female Pipe Size	Nozzle Number	K Factor	LITERS PER MINUTE @ BAR								Approx. (mm) Free Orifice Pass.		Approximate Dimensions (mm)						Wt. (kg) Male
				0.5 bar	0.7 bar	1 bar	2 bar	3 bar	5 bar	10 bar	20 bar	Dia.	Pass.	A	B	C	D	E	F	
1/4		ST6	3.19	2.26	2.67	3.19	4.5	5.5	7.1	10.1	14.3	2.38	2.38	63.5	65.0	30.0	17.5	17.5	20.6	0.09
		ST8	5.93	4.19	4.96	5.93	8.4	10.3	13.2	18.7	26.5	3.18	3.18	65.0	65.0	29.2	17.5	17.5	20.6	
		ST10	9.12	6.45	7.63	9.12	12.9	15.8	20.4	28.8	40.8	3.97	3.18	65.0	65.0	29.7	17.5	17.5	20.6	
3/8		ST12	13.7	9.67	11.4	13.7	19.3	23.7	30.6	43.2	61.1	4.76	3.18	74.7	74.7	33.3	23.9	23.9	28.7	0.14
		ST14	18.5	13.1	15.4	18.5	26.1	32.0	41.3	58.4	82.6	5.56	3.18	73.2	74.7	31.8	23.9	23.9	28.7	
		ST16	24.2	17.1	20.2	24.2	34.2	41.8	54.0	76.4	108	6.35	3.18	73.2	74.7	34.5	23.9	23.9	28.7	
		ST20	37.6	26.6	31.5	37.6	53.2	65.1	84.1	119	168	7.94	3.18	73.2	74.7	31.8	23.9	23.9	28.7	
3/4		ST24	54.9	38.8	46.0	54.9	77.7	95.1	123	174	246	9.53	4.76	90.4	95.3	30.2	35.1	35.1	38.1	0.28
		ST28	75.2	53.2	62.9	75.2	106	130	168	238	336	11.1	4.76	89.7	95.3	45.2	35.1	35.1	38.1	
		ST32	95.7	67.7	80.1	95.7	135	166	214	303	428	12.7	4.76	93.7	95.3	44.7	35.1	35.1	38.1	
1		ST40	153	108	128	153	216	264	341	483	683	15.9	6.35	116	116	61.0	47.8	44.5	50.8	0.57
		ST48	216	153	181	216	306	375	484	685	968	19.1	6.35	116	116	60.5	47.8	44.5	50.8	
1 1/2		ST56	294	208	246	294	416	509	657	930	1320	22.2	7.94	143	145	84.8	49.3	54.1	55.6	0.79
		ST64	385	272	322	385	545	667	861	1220	1720	25.4	7.94	143	145	85.6	49.3	54.1	55.6	
		ST72	438	309	366	438	619	758	978	1380	1960	28.6	7.94	143	145	83.8	49.3	54.1	55.6	
2	2 1/2	ST88	638	451	534	638	902	1110	1430	2020	2850	34.9	11.1	194	162	121	76.2	88.9	88.9	2.27
	3	ST96*	806	570	674	806	1140	1400	1800	2550	3600	38.1	11.1	229	210	143	92.2	102	102	
3	3	ST112*	1170	826	977	1170	1650	2020	2610	3690	5220	44.5	14.3	251	168	92.2	102	102	102	4.08
		ST128*	1540	1090	1290	1540	2180	2670	3450	4880	6900	50.8	14.3	270	185	92.2	102	102	102	
4	4	ST160*	2390	1690	2000	2390	3380	4140	5350	7570	10700	63.5	15.9	295	208	116	127	127	127	6.35

Flow Rate (l/min) =  $K \sqrt{\text{bar}}$  \*Three turn nozzles \*\*Parallel threads only

Standard Materials: Base and Caps - 316 Stainless Steel; Tip - Cobalt Alloy 6 or RBSC Ceramic. (RBSC not available on nozzle numbers ST6 - ST32).

Spray angle performance varies with pressure. Contact BETE for specific data on critical applications.

TO ORDER: specify pipe size, connection type, nozzle number, spray angle, and material.



# STXP

## Largest Free Passage

### DESIGN FEATURES

- Abrasion resistant
- Cobalt Alloy 6 or RBSC ceramic parts in high-wear areas
- High energy efficiency
- Largest free passage in spiral design
- Extra heavy, rugged construction
- Male and female connections
- Flanged and special connections available as required

### SPRAY CHARACTERISTICS

- Fine atomization
- Spray pattern:** Full Cone (Hollow Cone available by special order)
- Spray angles:** 90° and 120° standard
- Flow rates:** 9.67 to 10700 l/min (Higher flow rates available)



3-piece male

FULL CONE



Full Cone 90° (XPN)

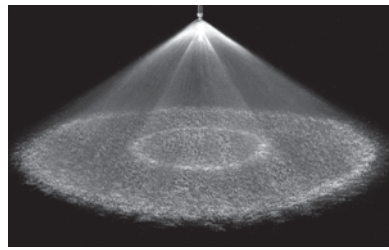

Full Cone 120° (XP)



3-piece Male

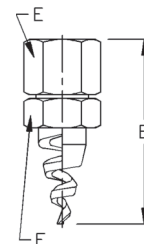

3-piece Female

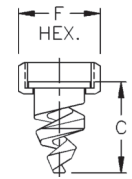

2-piece Female

Dimensions are approximate. Check with BETE for critical dimension applications.

### STXP Flow Rates & Dimensions

Full Cone, 90° (XPN) and 120° (XP) Spray Angles, 3/8" to 4" Pipe Sizes, BSP or NPT

3 piece Male or Female Pipe Size	** 2 piece Female Pipe Size	Nozzle Number	K Factor	LITERS PER MINUTE @ BAR								Approx. (mm) Orifice & Free Pass. Dia.	Approximate Dimensions (mm)						Wt. (kg) Metal	
				0.5 bar	0.7 bar	1 bar	2 bar	3 bar	5 bar	10 bar	20 bar		A	B	C	D	E	F	Male	Fem.
3/8		ST12	13.7	9.67	11.4	13.7	19.3	23.7	30.6	43.2	61.1	4.83	100	85.9	54.1	35.1	35.1	38.1	0.23	0.23
		ST14	18.5	13.1	15.4	18.5	26.1	32.0	41.3	58.4	82.6	5.59	100	85.9	53.6	35.1	35.1	38.1		
		ST16	24.2	17.1	20.2	24.2	34.2	41.8	54.0	76.4	108	6.35	100	85.9	53.8	35.1	35.1	38.1		
		ST20	37.6	26.6	31.5	37.6	53.2	65.1	84.1	119	168	7.87	100	85.9	53.8	35.1	35.1	38.1		
3/4		ST24	54.9	38.8	46.0	54.9	77.7	95.1	123	174	246	9.65	114	96.8	68.1	30.2	44.5	0.51	0.51	
		ST28	75.2	53.2	62.9	75.2	106	130	168	238	336	11.2	114	96.8	68.1	30.2	44.5			
		ST32	95.7	67.7	80.1	95.7	135	166	214	303	428	12.7	152	130	107	38.1	38.1			55.6
1		ST40	153	108	128	153	216	264	341	483	683	16.0	160	135	103	47.8	47.8	69.9	1.36	1.19
		ST48	216	153	181	216	306	375	484	685	968	19.5	189	164	141	47.8	47.8	69.9		
1 1/2	2 1/2	ST56	294	208	246	294	416	509	657	930	1320	22.4	217	184	140	76.2	76.2	88.9	2.72	1.53
		ST64	385	272	322	385	545	667	861	1220	1720	25.4	217	184	145	76.2	76.2	88.9		
		ST72	438	309	366	438	619	758	978	1380	1960	28.7	224	194	146	76.2	76.2	88.9		
2	3	ST88	638	451	534	638	902	1110	1430	2020	2850	35.1	298	203	213	92.2	92.2	102	3.63	1.81
		ST96	806	570	674	806	1140	1400	1800	2550	3600	38.1	290	259	218	92.2	92.2	102		
3	3	ST112	1170	826	977	1170	1650	2020	2610	3690	5220	44.5*	301	300	217	92.2	102	102	4.54	2.67
		ST128	1540	1090	1290	1540	2180	2670	3450	4880	6900	50.8*	320	300	217	92.2	102	102		
4	4	ST160	2390	1690	2000	2390	3380	4140	5350	7570	10700	63.5*	330	330	254	127	127	127	5.44	4.54

Flow Rate (l/min) = K√bar \*Free Passage is 38.1 mm \*\*Parallel threads only

Standard Materials: Base and Caps - 316 Stainless Steel; Tip - Cobalt Alloy 6 or RBSC Ceramic. (RBSC not available on nozzle numbers ST6 - ST32).

Spray angle performance varies with pressure. Contact BETE for specific data on critical applications.

# WL

## Low Flow/Full Cone

### DESIGN FEATURES

- Advanced whirl plate design produces extremely uniform coverage
- Male and female connections

### SPRAY CHARACTERISTICS

- Medium to coarse atomization
- Spray pattern:** Full Cone. Square pattern available
- Spray angles:** 30°, 60°, 90°, and 120° standard
- Flow rates:** 0.497 to 192 l/min



Metal

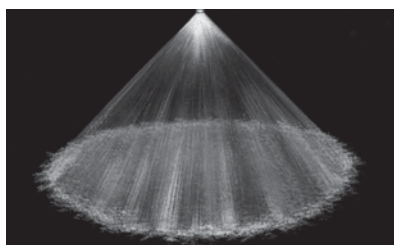

Full Cone 90°

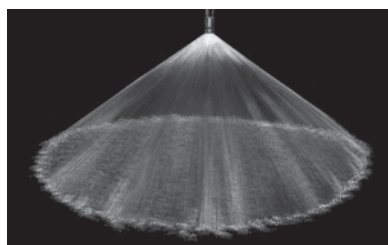

Full Cone 120°

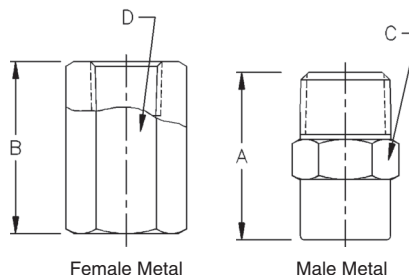

Female Metal

Male Metal

Dimensions are approximate. Check with BETE for critical dimension applications.

### WL Flow Rates and Dimensions

Full Cone, 30°, 60°, 90° and 120° Spray Angles, BSP or NPT

Male or Female Pipe Size	Nozzle Number	K Factor	LITERS PER MINUTE @ BAR								Approx. Orifice Dia. (mm)	Dimensions for Metal Only (mm)				Wt. (g) Metal Plas.	
			0.7 bar	1 bar	2 bar	3 bar	5 bar	10 bar	15 bar	20 bar		A	B	C	D		
1/8*	WL 1/4**	0.587	0.497	0.587	0.814	0.984	1.25	1.73	2.10	2.40	1.09	22.2	28.6	11.1	14.3	28.4	7.1
	WL 1/2	1.17	0.993	1.17	1.63	1.97	2.50	3.47	4.19	4.80	1.40						
	WL 3/4	1.76	1.49	1.76	2.44	2.95	3.75	5.20	6.29	7.20	1.83						
1/4	WL 1	2.35	1.99	2.35	3.25	3.94	5.01	6.93	8.39	9.60	2.08	27.0	34.9	14.2	17.5	42.5	10.6
	WL 1 1/2	3.52	2.98	3.52	4.88	5.91	7.51	10.4	12.6	14.4	2.77						
3/8	WL 2	4.70	3.97	4.70	6.51	7.87	10.0	13.9	16.8	19.2	3.18	31.8	38.1	17.5	22.2	56.7	14.2
	WL 3	7.05	5.96	7.05	9.76	11.8	15.0	20.8	25.2	28.8	3.96						
	WL 4	9.40	7.95	9.40	13.0	15.7	20.0	27.7	33.6	38.4	4.78						
1/2	WL 5	11.7	9.93	11.7	16.3	19.7	25.0	34.7	41.9	48.0	5.16	38.1	50.8	22.2	28.6	85.1	28.4
	WL 6	14.1	11.9	14.1	19.5	23.6	30.0	41.6	50.3	57.6	5.56						
	WL 7	16.4	13.9	16.4	22.8	27.6	35.0	48.5	58.7	67.2	5.79						
3/4	WL 8	18.8	15.9	18.8	26.0	31.5	40.0	55.5	67.1	76.8	5.94	44.5	54.0	28.6	34.9	170	42.5
	WL 10	23.5	19.9	23.5	32.5	39.4	50.1	69.3	83.9	96.0	7.14						
	WL 12	28.2	23.8	28.2	39.0	47.2	60.1	83.2	101	115	7.92						
1	WL 15	35.2	29.8	35.2	48.8	59.1	75.1	104	126	144	8.33	55.6	60.3	34.9	41.3	397	99.2
	WL 20	47.0	39.7	47.0	65.1	78.7	100	139	168	192	9.53						

$$\text{Flow Rate (l/min)} = K (\text{bar})^{0.47}$$

Standard Materials: Brass, 303 Stainless Steel, 316 Stainless Steel, PVC, Polypropylene, and PTFE

\*1/8" PTFE and Polypropylene not available in 120°.

\*\*1/8 WL-1/4 not available in Polypropylene.

Spray angle performance varies with pressure. Contact BETE for specific data on critical applications.

# MaxiPass® L

**Low Flow, Full Cone, Maximum Free Passage**

## DESIGN FEATURES

- 1/8 and 1/4 pipe connection sizes
- Ultimate clog-resistant design, with the **largest free passage available** in an axial, full-cone nozzle
- Unique, S-shaped internal vanes allow free passage of particles
- High-energy efficiency
- Easily handles dirty, contaminated liquids
- Male connections
- Nozzle body available in Brass, 303, 316 Stainless Steel
- Vanes are 316 Stainless Steel for optimum wear and corrosion resistance

## SPRAY CHARACTERISTICS

- High reliability spray performance under the most difficult conditions
  - Uniform spray distribution
- Spray pattern:** Full Cone  
**Spray angles:** Narrow (N), Medium (M), Wide (W)  
**Flow rates:** 0.44 to 7.94 L/min



FULL CONE

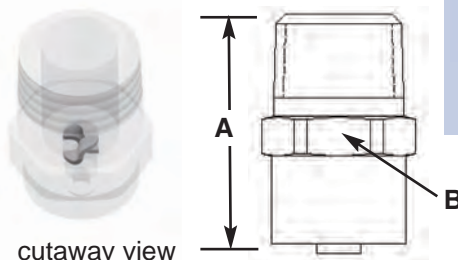

cutaway view

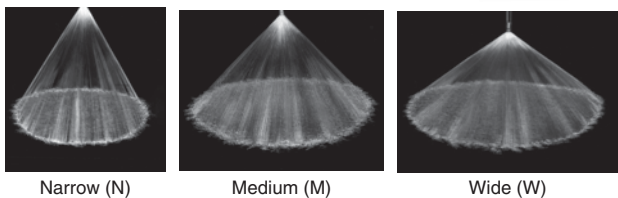

MaxiPass L Ordering Nomenclature			
1/8	MPL0.21	M	-B - 316
pipe connection size	series	flow rating	material
			BSP thread connection
			spray angle

## MaxiPass L (MPL) Flow Rates

Male Pipe Size	K Factor	Nozzle Number	LITERS PER MINUTE @ BAR						
			0.7 BAR	1 BAR	2 BAR	3 BAR	4 BAR	5 BAR	6 BAR
1/8	0.514	MPL0.21	0.44	0.51	0.69	0.82	0.93	1.03	1.11
	0.734	MPL0.30	0.63	0.73	0.99	1.18	1.33	1.47	1.59
	1.03	MPL0.42	0.88	1.03	1.39	1.65	1.87	2.06	2.23
	1.39	MPL0.57	1.19	1.39	1.87	2.23	2.52	2.78	3.00
1/4	1.88	MPL0.77	1.61	1.88	2.53	3.02	3.41	3.76	4.06
	2.74	MPL1.12	2.35	2.74	3.69	4.39	4.97	5.47	5.92
	3.69	MPL1.51	3.17	3.69	4.97	5.92	6.70	7.37	7.97

Flow Rate (L/min) = K (BAR)<sup>0.43</sup>

## Spray Angle and Dimensions

Nozzle Number	N spray angle	M spray angle	W spray angle	Approx. Free Passage Dia. (mm)			Approx. Dimensions (mm)		Wt. (g) Metal
	3 BAR	3 BAR	3 BAR	N	M	W	A length	B hex size	
MPL0.21	51	77	129	0.94	0.91	0.91	18	11.1	9
MPL0.30	53	86	134	1.1	0.99	1.1			
MPL0.42	51	90	128	1.3	1.2	1.1			
MPL0.57	61	92	127	1.5	1.4	1.3			
MPL0.77	62	90	125	1.7	1.7	1.7	22	14.3	18
MPL1.12	60	92	124	2.2	2.1	2.1			
MPL1.51	70	97	123	2.7	2.3	2.3			

Spray angle performance varies with pressure. Contact BETE Applications Engineering for specific data on critical applications.

Dimensions are approximate. Check with BETE for critical dimension applications.

CALL 413-772-0846  
Call for the name of your nearest BETE representative.



FULL CONE

# MaxiPass®

## Maximum Free Passage

### DESIGN FEATURES

- Ultimate clog-resistant design with largest free passage available in a full cone nozzle
- Two unique S-shaped internal vanes allow free passage of particles
- High energy efficiency
- Easily handles dirty, lumpy liquids
- Male and female connections
- Flanged connection available
- Patented design

### SPRAY CHARACTERISTICS

- High reliability spray performance under the most difficult conditions
- Spray pattern:** Full Cone (Square patterns to special order)
- Spray angles:** 30°, 60°, 90° and 120°
- Flow rates:** 2.60 to 3540 L/min (Flow rates up to 17,000 L/min available; call BETE Applications Engineering for details.)



Wide Angle Metal

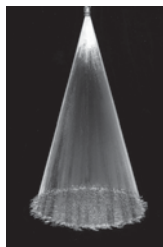

Full Cone 30° (NN)

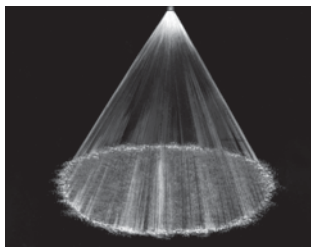

Full Cone 60° (N)

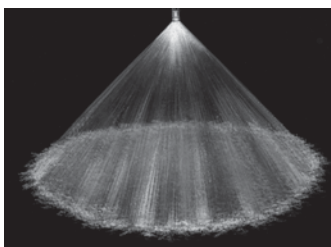

Full Cone 90° (M)

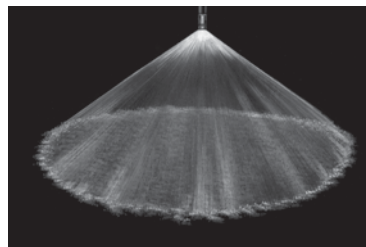

Full Cone 120° (W)

Dimensions are approximate. Check with BETE for critical dimension applications.

### MaxiPass Flow Rates and Dimensions

Full Cone, 30° (NN), 60° (N), 90° (M), and 120° (W) Spray Angles, 3/8" to 4" Pipe Sizes, BSP or NPT

Male or Female Pipe Size	Nozzle Number	K Factor	LITERS PER MINUTE @ BAR								Approx. Free Passage Dia. (mm)	Approx. Dimensions (mm) Overall Length					Wt.** (kg) Metal
			0.2 bar	0.3 bar	0.5 bar	0.7 bar	1 bar	2 bar	3 bar	5 bar		30° A	60° A	90° A	120° A	B	
3/8*	MP125	5.53	2.60	3.14	3.99	4.68	5.53	7.66	9.27	11.8	3.18	-	38.1	38.1	38.1	22.2	0.09
	MP156	8.79	4.13	4.99	6.35	7.43	8.79	12.2	14.7	18.7	3.97	-	38.1	38.1	38.1	22.2	0.09
	MP187	12.7	5.96	7.21	9.17	10.7	12.7	17.6	21.3	27.1	4.76	-	47.6	47.6	47.6	25.4	0.11
1/2*	MP187	12.7	5.96	7.21	9.17	10.7	12.7	17.6	21.3	27.1	4.76	-	47.6	47.6	47.6	25.4	0.11
	MP218	20.2	9.48	11.5	14.6	17.1	20.2	28.0	33.9	43.0	5.56	-	47.6	47.6	47.6	25.4	0.11
	MP250	22.7	10.7	12.9	16.4	19.2	22.7	31.4	38.0	48.4	6.35	-	47.6	47.6	47.6	25.4	0.11
3/4	MP281	27.9	13.1	15.8	20.1	23.6	27.9	38.6	46.8	59.4	7.14	-	63.5	60.3	63.5	31.8	0.23
	MP312	33.8	15.9	19.2	24.4	28.6	33.8	46.8	56.6	72.0	7.94	102	63.5	60.3	63.5	31.8	0.23
	MP343	41.4	19.4	23.5	29.9	35.0	41.4	57.3	69.4	88.2	8.73	102	63.5	60.3	63.5	31.8	0.20
	MP375	48.8	22.9	27.7	35.2	41.3	48.8	67.6	81.8	104	9.53	102	63.5	60.3	63.5	31.8	0.20
1	MP375	48.8	22.9	27.7	35.2	41.3	48.8	67.6	81.8	104	9.53	111	74.6	74.6	74.6	38.1	0.35
	MP406	58.5	27.5	33.2	42.2	49.2	58.5	81.0	98.0	125	10.3	111	74.6	74.6	74.6	38.1	0.33
	MP437	68.4	32.1	38.8	49.4	57.8	68.4	94.7	115	146	11.1	111	74.6	74.6	74.6	38.1	0.33
1 1/4	MP437	68.4	32.1	38.8	49.4	57.8	68.4	94.7	115	146	11.1	137	85.7	85.7	85.7	50.8	0.61
	MP500	87.9	41.3	49.9	63.5	74.3	87.9	122	148	187	12.7	137	85.7	85.7	85.7	50.8	0.61
	MP531	97.6	45.8	55.4	70.5	82.5	97.6	135	164	208	13.5	137	85.7	85.7	85.7	50.8	0.61
	MP562	107	50.2	60.8	77.3	90.5	107	148	179	228	14.3	137	85.7	85.7	85.7	50.8	0.61
1 1/2	MP562	107	50.2	60.8	77.3	90.5	107	148	179	228	13.97	184	111	111	111	57.2	0.91
	MP593	122	57.3	69.3	88.1	103	122	169	205	260	15.1	184	111	111	111	57.2	0.91
	MP625	130	61.0	73.8	93.9	110	130	180	218	277	15.9	184	111	111	111	57.2	0.91
	MP656	158	74.2	89.7	114	134	158	219	265	337	16.7	184	111	111	111	57.2	0.91
	MP687	166	77.9	94.3	120	140	166	230	278	354	17.5	184	111	111	111	57.2	0.91

Flow Rate (L<sub>min</sub>) = K (bar)<sup>0.47</sup> \*\* Weights given are for 60°, 90°, and 120° (PTFE not available in 3/8" and 1/2" sizes. Cobalt A6 not available in 3/8".)

Standard Materials: Brass, 316 Stainless Steel, PVC, Polypropylene, and PTFE

The spray angle of wide and medium angle whirl nozzles is affected by increasing pressure. \*3/8" and 1/2" sizes: 30° not available, 60° not available in plastic Contact BETE Applications Engineering when using the MaxiPass above 3 bar (40 PSI).

Spray angle performance varies with pressure. Contact BETE for specific data on critical applications.

TO ORDER: specify pipe size, connection type, nozzle number, spray angle, and material.





A cutaway view of the MaxiPass nozzle showing the S-shaped vanes that enable the nozzle to successfully handle large particles without clogging.

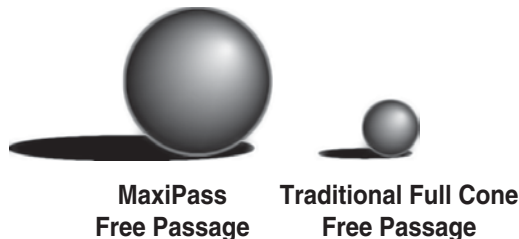

A comparison of the free passage available with the BETE MaxiPass nozzle compared to the free passage of a traditional full cone nozzle. The BETE MaxiPass is designed to pass solid particles that are 2-3 times larger in diameter than particles that will pass through a traditional full cone nozzle.

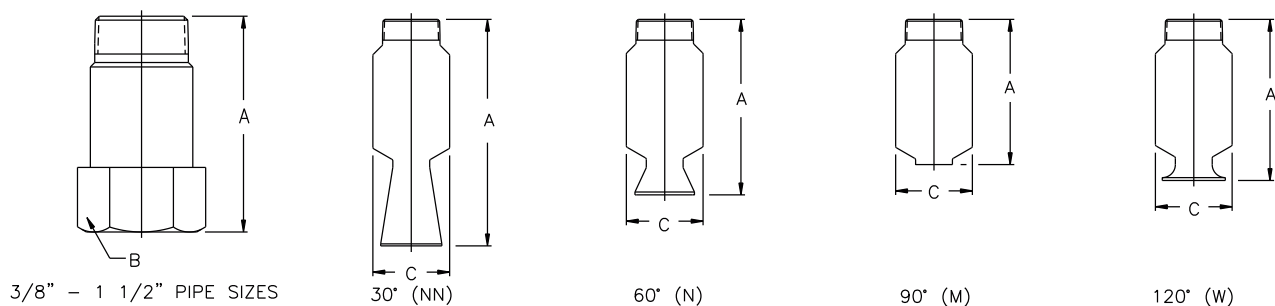

**For plastic dimensions, please call BETE Customer Service.**

**Dimensions are approximate. Check with BETE for critical dimension applications.**

**MaxiPass Flow Rates and Dimensions**

*Full Cone, 30°(NN), 60° (N), 90°(M), and 120°(W) Spray Angles, 3/8" to 4" Pipe Sizes, BSP or NPT*

Male or Female Pipe Size	Nozzle Number	K Factor	LITERS PER MINUTE @ BAR								Approx. Free Passage Dia. (mm)	Approx. Dimensions (mm) Overall Length					Wt.** (kg) Metal
			0.2 bar	0.3 bar	0.5 bar	0.7 bar	1 bar	2 bar	3 bar	5 bar		30° A	60° A	90° A	120° A	C*	
2	MP750	202	94.8	115	146	171	202	280	339	430	19.1						1.59
	MP812	221	104	126	160	187	221	306	370	471	20.6	210	183	146	159	66.8	
	MP875	273	129	155	197	231	273	378	458	582	22.2						
	MP937	306	144	174	221	259	306	424	513	652	23.8	229	194	152	165	82.6	
	MP1000	358	168	203	259	303	358	496	600	763	25.4						
MP1125	439	206	249	317	371	439	608	736	935	28.6	262	194	152	171	82.6		
2 1/2	MP1000	358	168	203	259	303	358	496	600	763	25.4	262	194	152	168	82.6	2.04
	MP1125	439	206	249	317	371	439	608	736	935	28.6	267	213	165	178	82.6	2.04
	MP1250	527	247	299	381	446	527	730	883	1120	31.5	305	244	165	181	82.6	2.04
	MP1375	632	297	359	456	535	632	875	1060	1350	34.9	305	244	213	229	102	2.84
	MP1500	774	363	440	559	655	774	1070	1230	1650	38.1	330	267	213	229	102	2.84
3	MP1500	774	363	440	559	655	774	1070	1230	1650	37.1	343	279	229	248	121	3.29
	MP1625	911	428	517	658	770	911	1260	1530	1940	41.3	343	279	229	251	121	3.29
	MP1750	1040	488	591	751	880	1040	1440	1740	2220	44.5	343	279	229	251	121	3.29
4	MP1750	1040	488	591	751	880	1040	1440	1740	2220	44.5	406	356	225	248	121	3.63
	MP1875	1170	549	664	845	989	1170	1620	1960	2490	47.6	406	356	225	248	121	3.63
	MP2000	1370	643	778	989	1160	1370	1900	2300	2920	49.8	406	356	286	311	152	7.26
	MP2125	1530	718	869	1100	1290	1530	2120	2560	3260	54.0	406	356	286	311	152	7.26
	MP2250	1660	779	943	1200	1400	1660	2300	2780	3540	57.2	406	356	286	311	152	7.26

Flow Rate (L/min) = K (bar)<sup>0.47</sup> \*C dimension for 30° (NN) is larger \*\*Weights given are for 60°, 90°, and 120°

**Standard Materials: Brass, 316 Stainless Steel, PVC, Polypropylene, and PTFE.**

Spray angle performance varies with pressure. Contact BETE for specific data on critical applications.

# CW

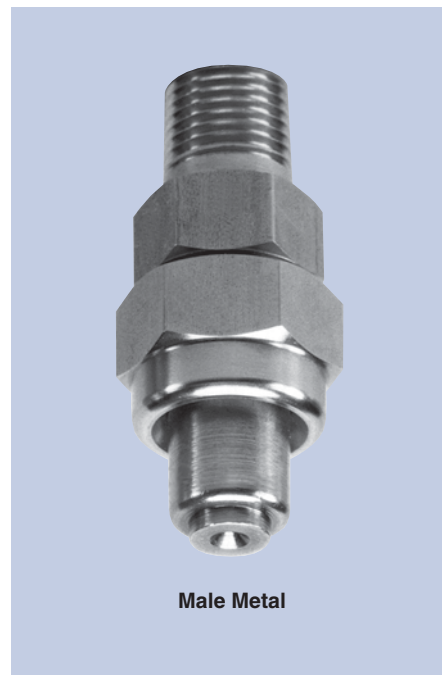

Male Metal

## Low Flow

### DESIGN FEATURES

- Standard 3-piece construction
- Optional 50- or 100-mesh strainer
- Male and female connections
- Interchangeable spray tips

### SPRAY CHARACTERISTICS

**Spray patterns:** Full Cone (F).  
 For Hollow Cone (H), see page 52.  
**Spray angles:** 80° and 120°  
**Flow rates:** 0.424 to 8.39 l/min

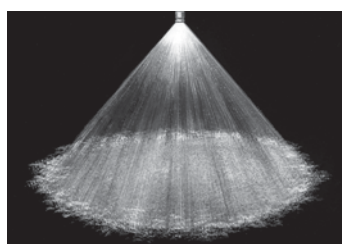

Full Cone 80° (F)

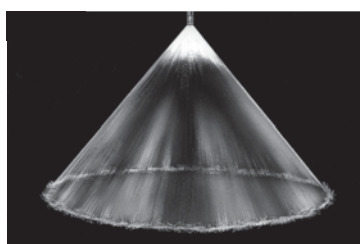

Hollow Cone 80° (H)

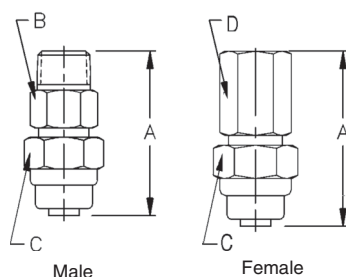

Male

Female

Dimensions are approximate. Check with BETE for critical dimension applications.

### CW Flow Rates and Dimensions

Full Cone, 80° and 120° Spray Angles, 1/8" to 3/8" Pipe Sizes, BSP or NPT

Male or Female Pipe Size	Nozzle Number	K Factor	LITERS PER MINUTE @ BAR								Approx. Orifice Dia.(mm)	Male or Female Pipe Size	Dimensions (mm)				Wt. (g) Metal
			0.5 bar	0.7 bar	1 bar	2 bar	3 bar	5 bar	10 bar	15 bar			A	B	C	D	
1/8 or 1/4 or 3/8	CW25-F	0.587	0.424	0.497	0.587	0.814	0.984	1.25	1.73	2.10	1.14	1/8-1/4	52.3	17.5	20.6	17.3	71
	CW50-F	1.17	0.848	0.993	1.17	1.63	1.97	2.50	3.47	4.19	1.37						
	CW75-F	1.76	1.27	1.49	1.76	2.44	2.95	3.75	5.20	6.29	1.60	3/8	52.3	17.5	20.6	20.6	
	CW100-F	2.35	1.70	1.99	2.35	3.25	3.94	5.01	6.93	8.39	2.18						

$$\text{Flow Rate (l/min)} = K(\text{bar})^{0.47}$$

Standard Materials: Brass, 303 Stainless Steel, and 316 Stainless Steel.

Spray angle performance varies with pressure. Contact BETE for specific data on critical applications.

# WTZ

## Right Angle Full Cone

### DESIGN FEATURES

- No internal parts, clog-resistant
- Uniform distribution
- Male and female connections
- Large free passage

### SPRAY CHARACTERISTICS

**Spray pattern:** Full Cone  
**Spray angle:** 90° and 110°  
**Flow rates:** 0.50 to 223 L/min

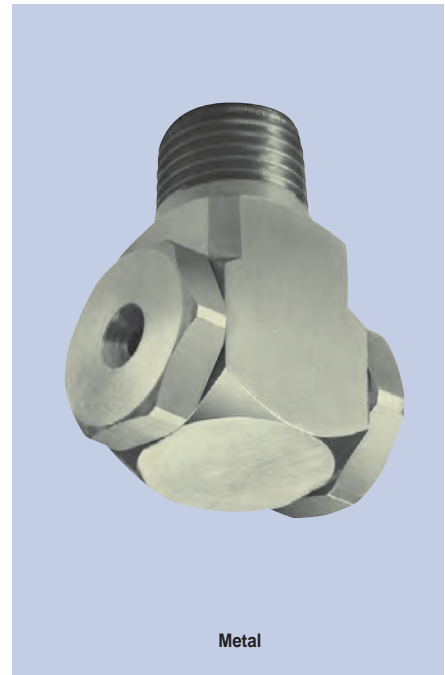

Metal

FULL CONE

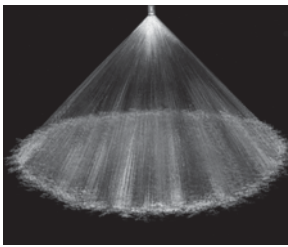

Full Cone 90°

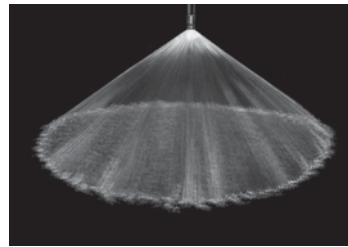

Full Cone 110°

Dimensions are approximate.  
 Check with BETE for critical dimension applications.

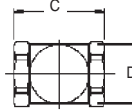
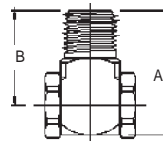

Metal

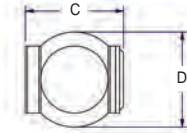
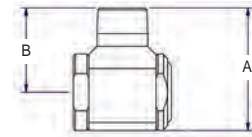

3/4" and 1"

Spray angle performance varies with pressure.

Contact BETE for specific data on critical applications.

### WTZ Flow Rates and Dimensions

Full Cone, 90° and 110° Spray Angles, 1/4", 3/8", 1/2", 3/4", and 1" Pipe Size, BSP or NPT

Male or Female Pipe Size	Nozzle Number	K Factor	LITERS PER MINUTE @ BAR							Approx. Orifice Dia. (mm)	Dimensions (mm) Metal Only			
			0.5 bar	1 bar	2 bar	3 bar	5 bar	7 bar	10 bar		A	B	C	D
1/4"	WTZ 50	1.13	0.80	1.13	1.60	1.96	2.53	2.99	3.58	1.90	33	25	20	16
	WTZ 56	1.27	0.90	1.27	1.80	2.20	2.84	3.36	4.02	2.00				
	WTZ 62	1.41	1.00	1.41	2.00	2.45	3.16	3.74	4.47	2.10				
	WTZ 77	1.77	1.25	1.77	2.50	3.06	3.95	4.67	5.59	2.30				
3/8"	WTZ 98	2.23	1.58	2.23	3.15	3.86	4.98	5.90	7.05	2.60	38	28	30	19
	WTZ 120	2.83	2.00	2.83	4.00	4.90	6.33	7.48	8.95	3.00				
	WTZ 150	3.53	2.50	3.53	5.00	6.12	7.90	9.35	11.2	3.30				
	WTZ 170	3.96	2.80	3.96	5.60	6.86	8.86	10.5	12.5	3.50				
	WTZ 200	4.46	3.15	4.46	6.30	7.72	10.0	11.8	14.1	3.70				
	WTZ 250	5.66	4.00	5.66	8.00	9.80	12.7	15.0	17.9	4.15				
	WTZ 280	6.36	4.50	6.36	9.00	11.0	14.2	16.8	20.1	4.40				
	WTZ 310	7.07	5.00	7.07	10.0	12.3	15.8	18.7	22.4	4.65				
	WTZ 390	8.84	6.25	8.84	12.5	15.3	19.8	23.4	28.0	5.20				
WTZ 500	11.3	8.00	11.3	16.0	19.6	25.3	29.9	35.8	5.80					
1/2"	WTZ 620	14.1	10.0	14.1	20.0	24.5	31.6	37.4	44.7	7.30	47	35	38	25
	WTZ 780	17.7	12.5	17.7	25.0	30.6	39.5	46.8	55.9	8.00				
	WTZ 980	22.3	15.8	22.3	31.5	38.6	49.8	58.9	70.4	8.70				
	WTZ1120**	25.5	18.1	25.5	36.1	44.2	57.1	67.5	80.7	9.87				
	WTZ1280**	29.2	20.6	29.2	41.3	50.5	65.2	77.2	92.2	10.7				
	WTZ1440**	32.8	23.2	32.8	46.4	56.8	73.4	86.8	103.8	9.93				
3/4"*	WTZ1200	27.3	19.3	27.4	38.7	47.4	61.2	72.4	86.5	8.51	76	51	51	51
	WTZ1500	34.2	24.2	34.2	48.3	59.2	76.4	90.4	108	10.5				
	WTZ1900	43.3	30.6	43.3	61.2	75.0	96.8	115	137	11.9				
1"*	WTZ2200	50.1	35.5	50.1	70.9	86.8	112	133	159	12.7	81	56	65	63
	WTZ3100	70.6	50.0	70.7	99.9	122	158	187	223	13.5				

Flow Rate (L/min) =  $K \sqrt{\text{bar}}$

Standard Materials: Brass, PVC, 303 Stainless Steel and 316 Stainless Steel.

\*Male threads ONLY. Female threads available on request. \*\*90° Spray Angle ONLY; other angles available on request.

Spray angle performance varies with pressure. Contact BETE for specific data on critical applications.

CALL 413-772-0846  
 Call for the name of your nearest BETE representative.



# EZ<sub>TF WL</sub>

## EZ Change Quick Connection System

### DESIGN FEATURES

- Nozzles can be changed in seconds without tools
- Three part nozzle, base, gasket and interchangeable tip
- Exclusive ramped engagement for efficient, automatic alignment
- Threaded adapters will accommodate other standard BETE nozzles. Shut-off plugs are also available
- Sanitary EZs are available with weld connection and no knurling

### SPRAY CHARACTERISTICS

- Available in six standard tips: EZTF; EZWL; EZWT; EZFF; EZNF; EZSPN

#### More EZ tips:

Hollow Cone: page 54 and 55  
Flat Fan: pages 72 and 73

**Flow rates:** 0.13 to 206 l/min

#### Spray Angle:

**EZTF:** 60°, 90°, 120°, 150°, and 170°

**EZWL:** 30°, 60°, 90°, 120°



EZTF

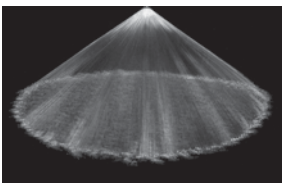

120° Full Cone

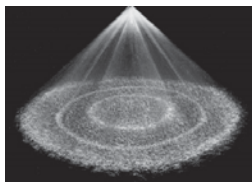

90° Full Cone Spiral

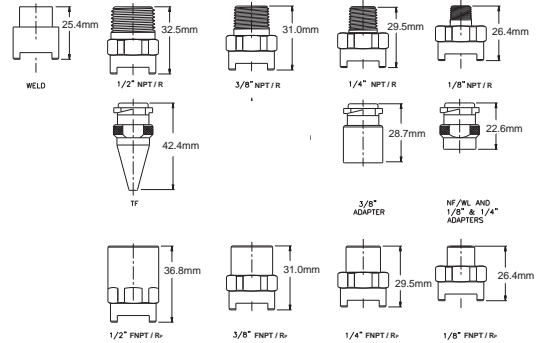

### EZTF Flow Rates and Dimensions

Full Cone Spiral 60° (NN), 90° (FCN), 120° (FC), 150°, or 170° Spray Angle 1/8" to 1/2" BSP or NPT

Pipe Size	Nozzle Number	K Factor	LITERS PER MINUTE @ BAR											Approx. Orifice Dia. (mm)	Approx. Assembly Dim. (mm)		Wt. (g)		
			0.3 bar	0.5 bar	0.7 bar	1 bar	2 bar	3 bar	5 bar	7 bar	10 bar	15 bar	20 bar		30 bar	Hex		Length	
1/8"	EZTF6	3.19	1.75	2.26	2.67	3.19	4.51	5.53	7.13	8.44	10.1	12.4	14.3	17.5	2.38	1/8"	22.4	41.4	62
	TO EZTF8	5.93	3.25	4.19	4.96	5.93	8.38	10.3	13.2	15.7	18.7	22.9	26.5	32.5	3.18				
1/2"	EZTF10	9.12	4.99	6.45	7.63	9.12	12.9	15.8	20.4	24.1	28.8	35.3	40.8	49.9	3.97	1/4"	22.4	44.5	62
	TO EZTF12	13.7	7.49	9.7	11.4	13.7	19.3	23.7	30.6	36.2	43.2	53.0	61.1	74.9	4.76				
1/4"	EZTF14	18.5	10.1	13.1	15.4	18.5	26.1	32.0	41.3	48.8	58.4	71.5	82.6	101	5.56	3/8"	22.4	46.0	74
	TO EZTF16	24.2	13.2	17.1	20.2	24.2	34.2	41.8	54.0	63.9	76.4	93.6	108	132	6.35				
1/2"	EZTF20	37.6	20.6	26.6	31.5	37.6	53.2	65.1	84.1	99.5	119	146	168	206	7.94	1/2"	22.4	47.5	82

Flow Rate (l/min) =  $K \sqrt{\text{bar}}$

Standard Materials: Brass; Viton gaskets standard. 316 Stainless Steel available upon request.

### EZWL Flow Rates and Dimensions

Full Cone Whirl 30°, 60°, 90°, 120° Spray Angle 1/8" to 1/2" BSP or NPT

Pipe Size	Nozzle Number	K Factor	LITERS PER MINUTE @ BAR							Approx. Orifice Dia (mm)	Pipe Size	Approx. Assembly Dim. (mm)		Wt. (g)
			0.2 bar	0.5 bar	0.7 bar	1 bar	2 bar	3 bar	5 bar			Hex	Length	
1/8"	EZWL 1/4	0.587	0.276	0.424	0.497	0.587	0.814	0.984	1.25	1.09	1/8"	22.4	41.4	62
	EZWL 1/2	1.17	0.551	0.848	0.993	1.17	1.63	1.97	2.50	1.40				
	EZWL 3/4	1.76	0.827	1.27	1.49	1.76	2.44	2.95	3.75	1.83				
TO	EZWL1	2.35	1.10	1.70	1.99	2.35	3.25	3.94	5.01	2.08	1/4"	22.4	44.5	62
	EZWL 1 1/2	3.52	1.65	2.54	2.98	3.52	4.88	5.91	7.51	2.77				
1/2"	EZWL2	4.70	2.21	3.39	3.97	4.70	6.51	7.87	10.0	3.18	3/8"	22.4	46.0	74
	EZWL3	7.05	3.31	5.09	5.96	7.05	9.76	11.8	15.0	3.96				
	EZWL4	9.40	4.41	6.78	7.95	9.40	13.0	15.7	20.0	4.78				
	EZWL5	11.7	5.51	8.48	9.93	11.7	16.3	19.7	25.0	5.16				
	EZWL6	14.1	6.62	10.2	11.9	14.1	19.5	23.6	30.0	5.56				

Flow Rate (l/min) =  $K (\text{bar})^{0.47}$

Note: Square pattern also available

Standard Materials: 303 Stainless Steel, 316 Stainless Steel, Brass; Viton gaskets standard.

TO ORDER: specify pipe size, connection type, nozzle number, spray angle, and material.

# SF

## Snap Release Nozzle System

### DESIGN FEATURES

- Nozzles can be quickly changed and aligned by hand without tools
- Clamp-on adapter fits any style nozzle
- Quick set-up system features special "Snap-in" tips
- Polypropylene, resistant to most acids and alkalis
- Double clamp base or adapter available for higher pressure operation

### SPRAY CHARACTERISTICS

- Quick Set-up System can be provided with fan, hollow or full cone spray tips
- Full 45° alignment of spray without tools

### More SF Nozzle Systems:

Hollow Cone: page 56

Flat Fan: page 74

**Flow rates:** 1.61 to 75.6 l/min

**Spray angles:**

**Full Cone:** 35°, 65°, 80°

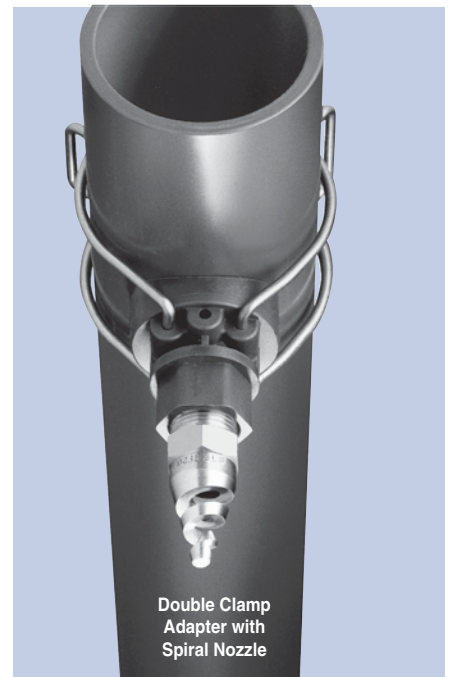

FULL CONE

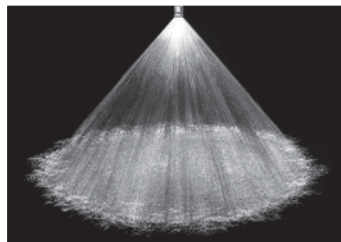

80° Full Cone

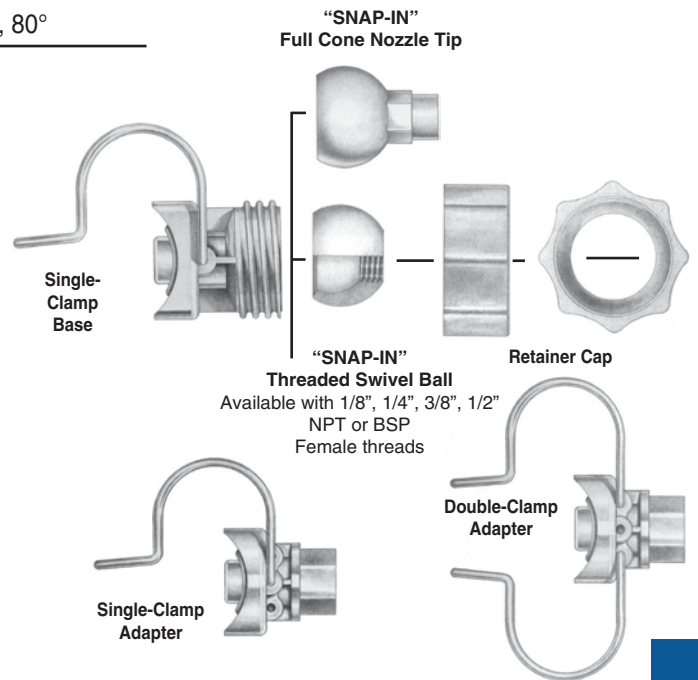
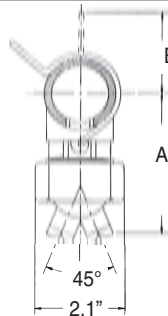

### CLAMP-ON ADAPTER

- Available for 1", 1-1/4", 1-1/2" and 2" pipe.
- Available with 1/8", 1/4", 3/8", 1/2" NPT female threads; or 1/8" BSP female threads
- Available with single or double clamp.
- **TO ORDER ADAPTER Specify: Pipe Size, thread size, thread type, number of clamps, materials.**

### SF Flow Rates and Dimensions

SF Full Cone 35°, 65° and 80° Spray Angles 1", 1-1/4", 1-1/2" and 2"

Nozzle Number	Available Spray Angle	K Factor	LITERS PER MINUTE @ BAR								Pipe Size	Body Color	Approx Dim. (mm)		Wt. (g)
			0.5 bar	0.7 bar	1 bar	2 bar	3 bar	5 bar	7 bar	10 bar			A	B	
SF31FC	35°	7.596	5.45	6.40	7.60	10.6	12.9	16.4	19.3	22.9	1"	blue	83.8	43.2	62.4
SF32FC	80°	7.855	5.63	6.62	7.86	11.0	13.3	17.0	20.0	23.7	1-1/4"	red	86.4	48.3	62.4
SF102FC	65°	25.02	17.9	21.1	25.0	34.9	42.4	54.2	63.7	75.6	1-1/2"	purple	91.4	50.8	62.4
											2"	green	94.0	55.9	62.4

$$\text{Flow Rate (l/min)} = K (\text{bar})^{0.48}$$

**Standard Materials:** Polypropylene, 302 Stainless Steel clamp, EPDM seal.

**Optional Materials:** 303 Stainless Steel clamp, Viton seal.

**NOTE:** Drill 16.7mm (21/32") hole in pipe to install SF.

**NOTE:** Maximum recommended pressures for SF assemblies: With single clamp 5 bar for 1" pipe; 3.5 bar for 1-1/4" and 1-1/2" pipe; and 2 bar for 2" pipe; with double clamp up to 10 bar.

Spray angle performance varies with pressure. Contact BETE for specific data on critical applications.

# SC

## Metal Alloy Line

### DESIGN FEATURES

- Complete line of full cone nozzles made in cast metal alloys
- Internal removable vane available
- Male and female connections
- Flanged connections available
- For plastic nozzles, see NC (pp. 42, 43), or MaxiPass (pp.34)

### SPRAY CHARACTERISTICS

- **Spray pattern:** Full Cone with uniform distribution. For square spray patterns, please contact BETE.
- **Spray angles:** 60°, 90°, and 120°
- **Flow rates:** 6.25 to 8180 l/min



Male

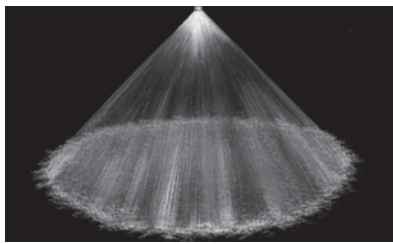

Full Cone 90°(M)

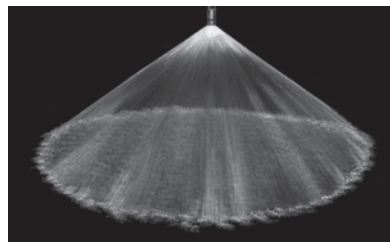

Full Cone 120°(W)

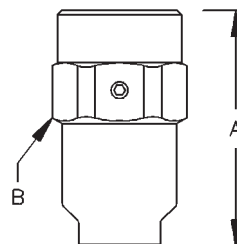

60° / 90° / 120° Female

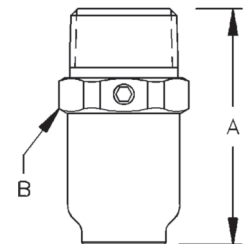

60° / 90° / 120° Male

Dimensions are approximate. Check with BETE for critical dimension applications.

### SC Flow Rates & Dimensions

Full Cone, Narrow 60° (N), Medium 90° (M) and Wide 120° (W) Spray Angles, 3/4" to 6" Pipe Sizes, BSP or NPT

Male or Female Pipe Size	Nozzle Number	Available Spray Angles			K Factor	LITERS PER MINUTE @ BAR							Approx. Orifice Dia. (mm)	Approx. Free Pass. Dia. (mm)	Dim. (mm)		Wt. (kg) Metal	
		60°	90°	120°		0.2 bar	0.3 bar	0.7 bar	1 bar	2 bar	3 bar	5 bar			7 bar	A		B
3/4	SC 2.5	60°	90°		13.3	6.25	7.57	11.3	13.3	18.5	22.3	28.4	33.3	4.76		50.8	31.0	0.23
	SC 3	60°	90°	120°	16.0	7.50	9.08	13.5	16.0	22.1	26.8	34.1	39.9	5.16				
	SC 4	60°	90°	120°	21.3	10.0	12.1	18.0	21.3	29.5	35.7	45.4	53.2	7.14	4.83			
	SC 6		90°	120°	32.0	15.0	18.2	27.0	32.0	44.3	53.6	68.1	79.8	7.54				
	SC 7		90°	120°	37.3	17.5	21.2	31.6	37.3	51.7	62.5	79.5	93.1	8.89				
1	SC 4.2	60°	90°		22.4	10.5	12.7	18.9	22.4	31.0	37.5	47.7	55.9	6.35	6.35	73.2	38.1	0.36
	SC 7	60°	90°	120°	37.3	17.5	21.2	31.6	37.3	51.7	62.5	79.5	93.1	8.33	7.87			
	SC 8	60°	90°	120°	42.6	20.0	24.2	36.1	42.6	59.1	71.5	90.9	106	8.89	7.87			
	SC 9	60°	90°	120°	48.0	22.5	27.2	40.6	48.0	66.4	80.4	102	120	10.2	7.87			
	SC 10	60°	90°	120°	53.3	25.0	30.3	45.1	53.3	73.8	89.3	114	133	10.7	7.87			
	SC 11	60°	90°	120°	58.6	27.5	33.3	49.6	58.6	81.2	98.3	125	146	11.2	7.87			
1 1/4	SC 12		90°	120°	64.0	30.0	36.3	54.1	64.0	88.6	107	136	160	11.7	7.87	88.9	47.6	0.59
	SC 6	60°	90°		32.0	15.0	18.2	27.0	32.0	44.3	53.6	68.1	79.8	7.62	7.62			
	SC 10	60°	90°		53.3	25.0	30.3	45.1	53.3	73.8	89.3	114	133	9.92	9.65			
	SC 12	60°	90°	120°	64.0	30.0	36.3	54.1	64.0	88.6	107	136	160	10.7	9.65			
	SC 14	60°	90°	120°	74.6	35.0	42.4	63.1	74.6	103	125	159	186	11.7	9.65			
	SC 16	60°	90°	120°	85.3	40.0	48.4	72.1	85.3	118	143	182	213	12.3	9.65			
SC 17	60°	90°	120°	90.6	42.5	51.5	76.6	90.6	126	152	193	226	13.5	9.65				
	SC 20		90°	120°	107	50.0	60.5	90.1	107	148	179	227	266	15.9	9.65			

$$\text{Flow Rate (l/min)} = K (\text{bar})^{0.47}$$

Standard Materials: Brass, Carbon Steel, and 316 Stainless Steel

Spray angle performance varies with pressure. Contact BETE for specific data on critical applications.



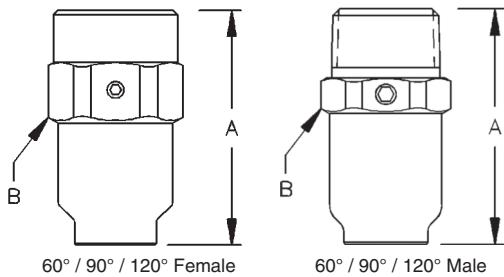

Dimensions are approximate. Check with BETE for critical dimension applications.

**SC Flow Rates & Dimensions**

Full Cone, Narrow 60° (N), Medium 90° (M) and Wide 120° (W) Spray Angles, 3/4" to 6" Pipe Sizes, BSP or NPT

Male or Female Pipe Size	Nozzle Number	Available Spray Angles			K Factor	LITERS PER MINUTE @ BAR							Approx. Free Pass.		Dim. (mm)		Wt. (kg) Metal	
		60°	90°	120°		0.2 bar	0.3 bar	0.7 bar	1 bar	2 bar	3 bar	5 bar	7 bar	Approx. Orifice Dia. (mm)	Free Pass. Dia. (mm)	A		B
1 1/2	SC 10	60°	90°		53.3	25.0	30.3	45.1	53.3	73.8	89.3	114	133	9.92	9.65	98.6	55.6	0.82
	SC 16	60°	90°	120°	85.3	40.0	48.4	72.1	85.3	118	143	182	213	13.5	9.65			
	SC 20	60°	90°	120°	107	50.0	60.5	90.1	107	148	179	227	266	14.3	10.4			
	SC 24	60°	90°	120°	128	60.0	72.6	108	128	177	214	273	319	15.9	10.4			
	SC 29		90°	120°	155	72.5	87.8	131	155	214	259	329	386	17.5	10.4			
	SC 30		90°	120°	160	75.0	90.8	135	160	221	268	341	399	19.1	10.4			
2	SC 17	60°	90°		90.6	42.5	51.5	76.6	90.6	126	152	193	226	12.3	12.2	130	69.9	1.50
	SC 30	60°	90°	120°	160	75.0	90.8	135	160	221	268	341	399	16.3	14.2			
	SC 35	60°	90°	120°	187	87.6	106	158	187	258	313	397	466	18.3	14.2			
	SC 40	60°	90°	120°	213	100	121	180	213	295	357	454	532	19.8	14.2			
	SC 47	60°	90°	120°	251	118	142	212	251	347	420	534	625	24.6	14.2			
	SC 50	60°	90°	120°	266	125	151	225	266	369	447	568	665	27.9	14.2			
	SC 60		90°	120°	320	150	182	270	320	443	536	681	798	29.0	19.1			
2 1/2	SC 25	60°	90°		133	62.5	75.7	113	133	185	223	284	333	15.5	15.5	160	82.6	2.95
	SC 50	60°	90°		266	125	151	225	266	369	447	568	665	22.1	19.1			
	SC 60	60°	90°	120°	320	150	182	270	320	443	536	681	798	24.4	19.1			
	SC 70	60°	90°	120°	373	175	212	316	373	517	625	795	931	27.2	19.1			
	SC 80	60°	90°	120°	426	200	242	361	426	591	715	909	1060	29.2	19.1			
	SC 90		90°	120°	480	225	272	406	480	664	804	1020	1200	32.3	19.1			
3	SC 42	60°	90°		224	105	127	189	224	310	375	477	559	19.1	19.1	182	95.3	4.26
	SC 58	60°	90°		309	145	176	261	309	428	518	659	772	22.9	22.9			
	SC 80	60°	90°	120°	426	200	242	361	426	591	715	909	1060	27.9	25.4			
	SC 90	60°	90°	120°	480	225	272	406	480	664	804	1020	1200	30.6	25.4			
	SC 95	60°	90°	120°	506	238	288	428	506	701	849	1080	1260	28.6	25.4			
	SC 100	60°	90°	120°	533	250	303	451	533	738	893	1140	1330	34.1	25.4			
	SC 117	60°	90°	120°	624	293	354	527	624	864	1050	1330	1560	36.1	25.4			
	SC 120	60°	90°	120°	640	300	363	541	640	886	1070	1360	1600	38.1	25.4			
	SC 135		90°	120°	720	338	409	608	720	997	1210	1530	1800	41.7	25.4			
4	SC 125	60°	90°		666	313	378	563	666	923	1120	1420	1660	34.3		219	121	7.17
	SC 130	60°	90°		693	325	393	586	693	960	1160	1480	1730	35.1				
	SC 160	60°	90°		853	400	484	721	853	1180	1430	1820	2130	40.6				
	SC 180	60°	90°	120°	959	450	545	811	959	1330	1610	2040	2390	43.7	33.8			
	SC 188	60°	90°	120°	1000	470	569	847	1000	1390	1680	2140	2500	42.9				
	SC 200	60°	90°	120°	1070	500	605	901	1070	1480	1790	2270	2660	47.6				
	SC 210	60°	90°	120°	1120	525	636	947	1120	1550	1880	2390	2790	51.6				
	SC 250		90°	120°	1330	625	757	1130	1330	1850	2230	2840	3330	57.0				
6	SC 350	60°	90°	120°	1860	876	1060	1580	1860	2580	3130	3980	4660	66.0	35.1	*	*	*
	SC 480		90°	120°	2560	1200	1450	2160	2560	3540	4290	5450	6390	71.1	42.9	*	*	*
	SC 615		90°	120°	3280	1540	1860	2770	3280	4540	5490	6980	8180	76.2	42.9	*	*	*

Flow Rate ( $l/min$ ) =  $K (bar)^{0.47}$  \* Dimensions vary with spray angle ordered, please call for dimensions and weights

Standard Materials: Brass, Carbon Steel, and 316 Stainless Steel

Spray angle performance varies with pressure. Contact BETE for specific data on critical applications.

# NC

## Threaded Connection/Plastic Material



Male 120°

### DESIGN FEATURES

- Complete line of full cone nozzles made of plastic and some bar stock metal alloy materials
- Uniform coverage
- Male and female connections
- Flanged connection available in larger models—see NCFL (p.46)
- For metal alloy nozzles, refer to MaxiPass (pp. 34), SC (pp. 40, 41), or TC (p. 47) Series

### SPRAY CHARACTERISTICS

- High flow rates with coarse atomization
- Spray pattern:** Full Cone. For square patterns, please contact BETE.
- Spray angles:** 60°, 90°, and 120° standard
- Flow rates:** 7.50 to 8180 l/min (Higher flow rates available)

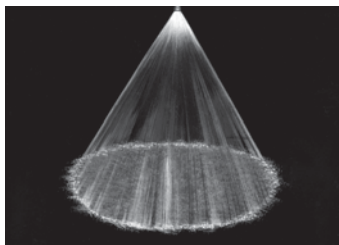

Full Cone 60° (N)

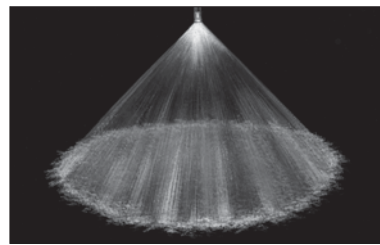

Full Cone 90° (M)

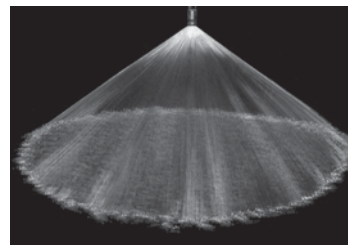

Full Cone 120° (W)

Dimensions are approximate. Check with BETE for critical dimension applications.

### NC Flow Rates and Dimensions

Full Cone, Narrow 60°(N), Medium 90°(M) and Wide 120° (W) Spray Angles, 3/4" to 6" Pipe Sizes, BSP or NPT

Male or Female Pipe Size	Nozzle Number	K Factor	LITERS PER MINUTE @ BAR								Approx. Orifice Dia. (mm)	Approx. Free Pass. Dia. (mm)	Dimensions (mm)				Wt. Male PVC (g)
			0.2 bar	0.5 bar	0.7 bar	1 bar	2 bar	3 bar	5 bar	7 bar			A	B	C	D	
3/4	NC 0703	16.0	7.50	11.5	13.5	16.0	22.1	26.8	34.1	39.9	6.35	4.06	44.5	28.4	53.8	38.1	28
	NC 0704	21.3	10.0	15.4	18.0	21.3	29.5	35.7	45.4	53.2	6.35	4.83					
	NC 0707	37.3	17.5	26.9	31.6	37.3	51.7	62.5	79.5	93.1	8.38	5.84					
1	NC 1009	48.0	22.5	34.6	40.6	48.0	66.4	80.39	102	120	9.65	6.35	55.6	34.9	63.5	44.5	35
	NC 1012	64.0	30.0	46.2	54.1	64.0	88.6	107	136	160	11.4	7.62					
1 1/4	NC 1214	74.6	35.0	53.9	63.1	74.6	103	125	159	186	11.9	8.64	82.6	44.5	82.6	50.8	106
	NC 1217	90.6	42.5	65.4	76.6	90.6	126	152	193	226	13.5	9.65					
1 1/2	NC 1516	85.3	40.0	61.6	72.1	85.3	118	143	182	213	12.7	9.65	108	50.8	108	63.5	191
	NC 1520	107	50.0	77.0	90.1	107	148	179	227	266	14.2	10.4					
	NC 1524	128	60.0	92.4	108	128	177	214	273	319	15.5	11.2					
2	NC 2017	90.6	42.5	65.4	76.6	91	126	152	193	226	13.5	9.65	148	63.5	148	76.2	361
	NC 2020	107	50.0	77.0	90.1	107	148	179	227	266	14.2	10.4					
	NC 2033	176	82.6	127	149	176	244	295	375	439	18.3	14.0					
	NC 2040	213	100	154	180	213	295	357	454	532	20.3	16.0					
	NC 2045	240	113	173	203	240	332	402	511	599	21.3	16.0					

$$\text{Flow Rate (l/min)} = K (\text{bar})^{0.47}$$

Standard Materials: PVC, Polypropylene, and PTFE.

**NOTE for PTFE nozzles:** if operating temperature is to exceed 150°C or the operating pressure is to exceed the values listed in the table above, please contact BETE Applications Engineering for assistance.

Spray angle performance varies with pressure. Contact BETE for specific data on critical applications.

TO ORDER: specify pipe size, connection type, nozzle number, spray angle, and material.

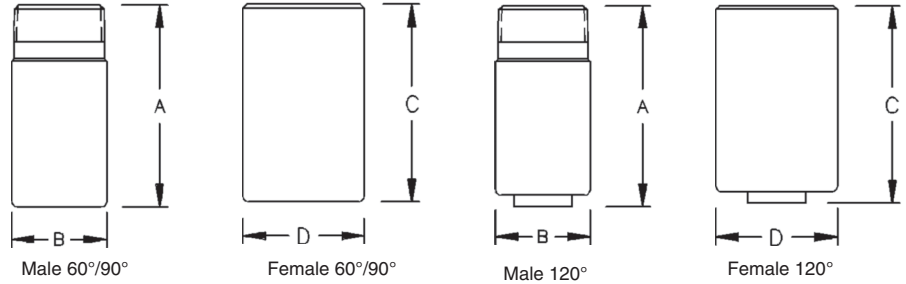

Dimensions are approximate. Check with BETE for critical dimension applications.

**NC Flow Rates and Dimensions**

Full Cone, Narrow 60° (N), Medium 90° (M) and Wide 120° (W) Spray Angles, 3/4" to 6" Pipe Sizes, BSP

Male or Female Pipe Size	Nozzle Number	K Factor	LITERS PER MINUTE @ BAR								Approx. Orifice Dia. (mm)	Approx. Free Pass. Dia. (mm)	Dimensions (mm)				Wt. Male PVC (g)
			0.2 bar	0.5 bar	0.7 bar	1 bar	2 bar	3 bar	5 bar	7 bar			A	B	C	D	
2	NC 2050	266	125	192	225	266	369	447	568	665	22.6	15.2	148	63.5	148	76.2	361
	NC 2060	320	150	231	270	320	443	536	681	23.9	16.0						
	NC 2065	346	163	250	293	346	480	581	738	25.4	17.0						
	NC 2070	373	175	269	316	373	517	625	795	26.7	17.3						
2 1/2	NC 2570	373	175	269	316	373	517	625	795	931	26.7	17.3	149	76.2	148	88.9	546
	NC 2580	426	200	308	361	426	591	715	909	1060	28.7	17.5					
	NC 2590	480	225	346	406	480	664	804	1020	1200	30.2	19.8					
3	NC 3058	309	145	223	261	309	428	518	659	772	24.1	16.0	149	88.9	148	102	645
	NC 3084	448	210	323	379	448	620	750	954	1120	29.7	22.4					
	NC 3096	512	240	369	433	512	709	858	1090	1280	28.4	24.1					
	NC 30117	624	293	450	527	624	864	1050	1330	1560	34.5	24.6					
4	NC 40125	666	313	481	563	666	923	1120	1420	1660	35.3	24.9	149	114	184	127	1320
	NC 40130	693	325	500	586	693	960	1160	1480	1730	35.3	24.9					
	NC 40180	959	450	693	811	959	1330	1610	2040	2390	42.9	33.3					
	NC 40250	1330	625	962	1130	1330	1850	2230	2840	3330	50.3	40.1					
6	NC 60350	1860	876	1350	1580	1860	2580	3130	3980	4660	60.5	43.2	241	168	279	178	3680
	NC 60480	2560	1200	1850	2160	2560	3540	4290	5450	6390	69.9	44.5					
	NC 60615	3280	1540	2370	2770	3280	4540	5490	6980	8180	79.0	50.0					

Flow Rate (l/min) = K (bar)<sup>0.47</sup>

Standard Materials: PVC, Polypropylene, and PTFE.

NOTE for PTFE nozzles: if operating temperature is to exceed 150°C or the operating pressure is to exceed the values listed in the table above, please contact BETE Applications Engineering for assistance.

Spray angle performance varies with pressure. Contact BETE for specific data on critical applications.



# NCS

## Stubbies/Minimize Head Space

### DESIGN FEATURES

- Takes no more room than pipe plug, yet performs like full-size nozzle
- Small projection
- Can be used with standard pipe couplings to form female nozzle, with elbows to form right angle nozzle, or with tees or crosses for multiple installations
- Male connection
- Metal and plastic materials

### SPRAY CHARACTERISTICS

- Spray pattern:** Full Cone  
**Spray angles:** 70°, 90° and 110° standard  
**Flow rates:** 7.50 to 1596 l/min (Special flow rates available)

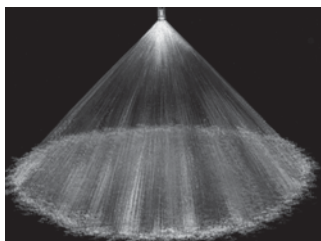

Full Cone 90° (M)

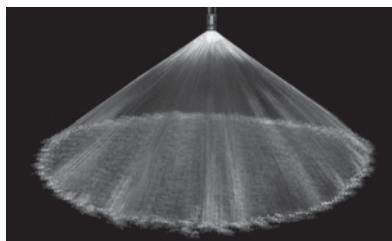

Full Cone 110° (W)

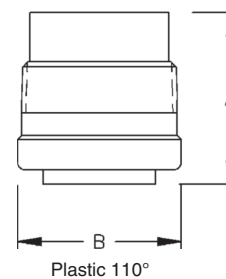
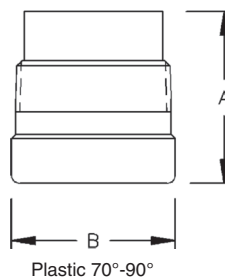

Dimensions are approximate. Check with BETE for critical dimension applications.

### NCS Flow Rates and Dimensions

Full Cone, Narrow 70° (N), Medium 90° (M), and Wide 110° (W) Spray Angles, 1" to 4" Pipe Sizes, BSP or NPT

Male Pipe Size	Nozzle Number	K Factor	LITERS PER MINUTE @ BAR								Approx. Orifice Dia. (mm)	Approx. Free Pass. Dia. (mm)	Dim. (mm)		Wt. PVC (g)
			0.2 bar	0.5 bar	0.7 bar	1 bar	2 bar	3 bar	5 bar	7 bar			A	B	
1	NCS1003	16.0	7.50	11.5	13.5	16.0	22.1	26.8	34.1	39.9	5.59	3.81	47.6	35.1	43
	NCS1005	26.6	12.5	19.2	22.5	26.6	36.9	44.7	56.8	66.5	7.11	5.59			
	NCS1007	37.3	17.5	26.9	31.6	37.3	51.7	62.5	79.5	93.1	8.38	5.33			
1 1/2	NCS1510	53.3	25.0	38.5	45.1	53.3	73.83	89.3	114	133	10.4	7.11	60.3	50.8	85
	NCS1513	69.3	32.5	50.0	58.6	69.3	95.97	116	148	173	11.4	9.65			
	NCS1516	85.3	40.0	61.6	72.1	85.3	118	143	182	213	12.7	9.14			
2	NCS2020	107	50.0	77.0	90.1	107	148	179	227	266	14.2	10.4	66.7	63.5	170
	NCS2025	133	62.5	96.2	113	133	185	223	284	333	16.3	11.4			
	NCS2030	160	75.0	115	135	160	221	268	341	399	17.5	13.2			
	NCS2035	187	87.6	135	158	187	258	313	397	466	19.1	14.0			
2 1/2	NCS2540	213	100	154	180	213	295	357	454	532	20.3	16.0	76.2	76.2	255
	NCS2545	240	113	173	203	240	332	402	511	599	21.3	16.0			
	NCS2550	266	125	192	225	266	369	447	568	665	22.6	16.0			
3	NCS3060	320	150	231	270	320	443	536	681	798	23.9	16.0	84.1	88.9	383
	NCS3070	373	175	269	316	373	517	625	795	931	26.7	14.7			
	NCS3085	453	213	327	383	453	628	759	965	1131	29.5	16.8			
4	NCS40100	533	250	385	451	533	738	893	1136	1330	31.8	24.1	102	114	567
	NCS40120	640	300	462	541	640	886	1072	1363	1596	35.1	25.4			

$$\text{Flow Rate (l/min)} = K (\text{bar})^{0.47}$$

Standard Materials: Brass, 316 Stainless Steel, Polypropylene, PVC, and PTFE.

Spray angle performance varies with pressure. Contact BETE for specific data on critical applications.

TO ORDER: specify pipe size, connection type, nozzle number, spray angle, and material.

# NCK

## Full Cone/Narrow Angle Injector

### DESIGN FEATURES

- Narrow spray angles
- High velocity
- Male and female connections
- Flanged connections available

### SPRAY CHARACTERISTICS

- Coarse and extremely hard-driving spray with even distribution

**Spray pattern:** Full Cone  
**Spray angles:** 15°, 20°, and 30°  
**Flow rates:** 23.1 to 4660 L/min  
 (Special flow rates available)



FULL CONE

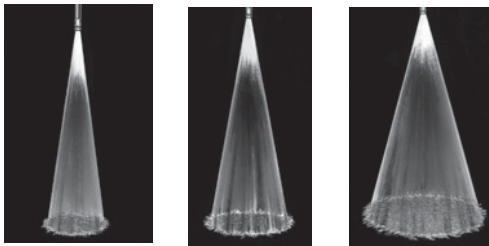

Full Cone 15°

Full Cone 20°

Full Cone 30°

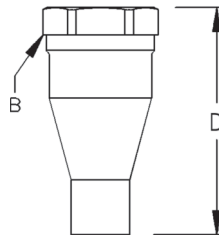

Female

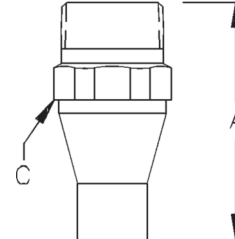

Male

Dimensions are approximate. Check with BETE for critical dimension applications.

### NCK Flow Rates and Dimensions

Full Cone, 15°, 20°, and 30° Spray Angles, 3/4" to 6" Pipe Sizes, BSP or NPT

Male or Female Pipe Size	Nozzle Number	K Factor	LITERS PER MINUTE @ BAR								Approx. Orifice Dia. (mm)	Dimensions for Metal Only (mm)				Wt. (kg)	
			0.5 bar	0.7 bar	1 bar	1.5 bar	2 bar	3 bar	5 bar	7 bar		A	B	C	D	PVC	Metal
3/4	NC 0706K	32.0	23.1	27.0	32.0	38.7	44.3	53.6	68.1	79.8	7.52	82.6	34.9	28.4	82.6	0.04	0.34
1	NC 1012K	64.0	46.2	54.1	64.0	77.4	88.6	107	136	160	10.3	88.9	44.5	35.1	88.9	0.06	0.45
1 1/4	NC 1218K	95.9	69.3	81.1	95.9	116	133	161	204	239	12.3	102	50.8	44.5	102	0.11	0.57
1 1/2	NC 1526K	139	100	117	139	168	192	232	295	346	15.1	127	63.5	50.8	127	0.20	1.02
2	NC 2048K	256	185	216	256	310	354	429	545	638	20.2	152	76.2	63.5	152	0.37	1.13
2 1/2	NC 2572K	384	277	325	384	464	532	643	818	958	24.6	178	82.6	76.2	194	0.62	2.61
3	NC 30105K	560	404	473	560	677	775	938	1190	1400	29.5	203	97.5	88.9	203	0.85	2.84
4	NC 40190K	1010	731	856	1013	1220	1400	1697	2160	2530	40.5	251	127	114	278	2.04	6.80
6	NC 60350K	1860	1380	1580	1860	2260	2580	3126	3980	4660	54.0	343	181	168	381	2.78	15.9

$$\text{Flow Rate (l/min)} = K (\text{bar})^{0.47}$$

Standard Materials: Brass, 316 Stainless Steel, PVC, Polypropylene, and PTFE.

**NOTE for PTFE nozzles:** if operating temperature is to exceed 150 °C or the operating pressure is to exceed the values listed in the table above, please contact BETE Applications Engineering for assistance.

Spray angle performance varies with pressure. Contact BETE for specific data on critical applications.

CALL 413-772-0846  
Call for the name of your nearest BETE representative.

# NCFL

## Flange Connection/Plastic Material



Plastic Flanged

### DESIGN FEATURES

- Large internal passages
- Uniform spray coverage
- High flow rates with coarse atomization
- Variety of polymer materials available, offering high corrosion resistance
- For metal alloy nozzles refer to SC (pp. 40, 41) and TC (p. 47)

### SPRAY CHARACTERISTICS

- Spray pattern:** Full Cone
- Spray angles:** 60°, 90°, and 120°
- Flow rates:** 350 to 19700 l/min (Special flow rates available)

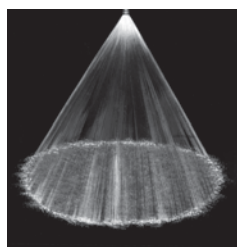

Full Cone 60° (N)

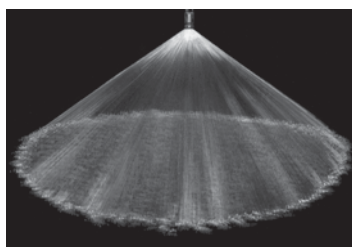

Full Cone 120° (W)

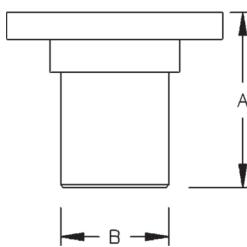

Flanged

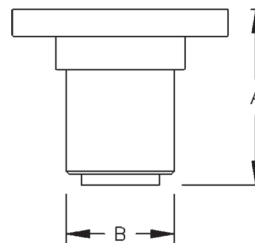

Flanged 120°

Dimensions are approximate. Check with BETE for critical dimension applications.

### NCFL Flow Rates and Dimensions

Full Cone, Narrow 60° (N), Medium 90° (M) and Wide 120° (W) Spray Angles, Flanged Connection, BSP or NPT

Pipe Size	Nozzle Number	K Factor	LITERS PER MINUTE @ BAR								Approx. Free Pass.		Dim. (mm)		Wt. PVC (kg)
			0.2 bar	0.3 bar	0.4 bar	0.5 bar	0.7 bar	1 bar	1.5 bar	2 bar	Approx. Orifice Dia. (mm)	Free Pass. Dia. (mm)	A	B	
4	NCFL40140	746	350	424	485	539	631	746	903	1030	37.6	25.4	149	114	3.63
	NCFL40180	959	450	545	624	693	811	959	1160	1330	42.9	33.3			
	NCFL40250	1330	625	757	866	962	1130	1330	1610	1850	50.3	40.1			
6	NCFL60350	1860	876	1060	1213	1350	1580	1860	2260	2580	60.5	43.2	254	168	6.35
	NCFL60480	2560	1200	1450	1663	1850	2160	2560	3100	3540	69.9	44.5			
	NCFL60615	3280	1540	1860	2131	2370	2770	3280	3970	4540	79.0	50.0			
8	NCFL80665	3540	1660	2010	2300	2560	3000	3540	4290	4910	82.6	53.8	305	219	11.8
	NCFL80775	4130	1940	2350	2690	2980	3490	4130	5000	5720	89.4	60.5			
	NCFL80885	4720	2210	2680	3070	3410	3990	4720	5710	6530	95.3	66.5			
12	NCFL1201280	6820	3200	3870	4430	4930	5770	6820	8260	9450	114	73.2	457	323	31.8
	NCFL1201910	10200	4780	5780	6620	7350	8610	10200	12300	14100	140	82.6			
	NCFL1202665	14200	6670	8070	9230	10300	12000	14200	17200	19700	159	88.9			

$$\text{Flow Rate (l/min)} = K (\text{bar})^{0.47}$$

Standard Materials: PVC, Polypropylene, and PTFE (12" NCFL not available in PTFE)

Spray angle performance varies with pressure. Contact BETE for specific data on critical applications.

# TC

## High Flow Rate/Metal Alloy Line

### DESIGN FEATURES

- One-piece body with integral vanes
- Male, female, and flanged connections available

### SPRAY CHARACTERISTICS

- Extremely high flow rates
- Spray pattern:** Full Cone
- Spray angles:** 60°, 90°, and 120°
- Flow rates:** 976 to 36100 L/min (Special flow rates available)

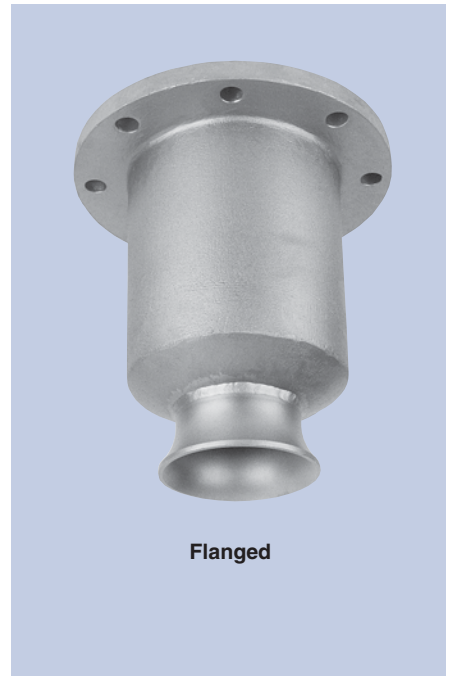

Flanged



FULL CONE

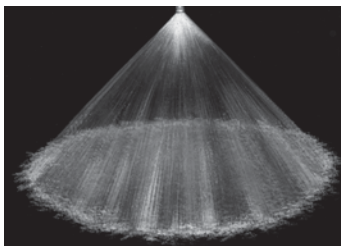

Full Cone 90° (M)

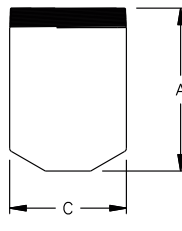

Male 60°/90°

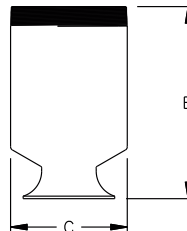

Male 120°

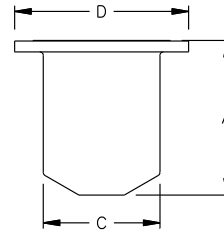

60°/90° Flanged

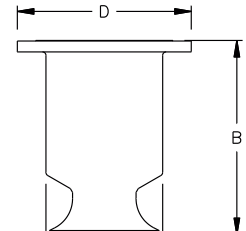

120° Flanged

Dimensions are approximate. Check with BETE for critical dimension applications.

### TC Flow Rates and Dimensions

Full Cone, Narrow 60° (N), Medium 90°(M), and Wide 120°(W) Spray Angles, 6" to 12" Pipe Sizes, BSP or NPT, 12" Flanged

Male or Female Pipe Size	Nozzle Number	Available Spray Angles	K Factor	LITERS PER MINUTE @ BAR								Approx. Free Pass. Dia. (mm)	Dimensions (mm)				Wt. (kg)
				0.1 bar	0.3 bar	0.5 bar	0.7 bar	1 bar	2 bar	3 bar	5 bar		A	B	C	D	
6	TC 532	60° 90° 120°	2820	976	1620	2050	2390	2820	3870	4670	5900	44.5	259		168		11.3
	TC 588	90° 120°	3110	1080	1790	2260	2640	3110	4280	5160	6520		259		168		
	TC 827	90° 120°	4380	1520	2520	3180	3710	4380	6020	7250	9180		260	313	168		
8	TC 962	60° 90° 120°	5090	1770	2930	3700	4320	5090	7000	8440	10700	52.3	324		219		18.1
	TC 1120	90° 120°	5930	2060	3410	4310	5030	5930	8150	9820	12400		324	389	219		
	TC 1260	60° 90° 120°	6670	2310	3830	4850	5660	6670	9170	11100	14000		324	389	219		
	TC 1480	90° 120°	7830	2720	4500	5690	6650	7830	10800	13000	16400			389	219		
<b>Flanged Connection</b>																	
6	TCFL532	60° 90° 120°	2820	976	1620	2050	2390	2820	3870	4670	5900	44.5	238		168	279	27.2
	TCFL588	90° 120°	3110	1080	1790	2260	2640	3110	4280	5160	6520		238		168	279	
	TCFL827	90° 120°	4380	1520	2520	3180	3710	4380	6020	7250	9180		238	292	168	279	
8	TCFL962	60° 90° 120°	5090	1770	2930	3700	4320	5090	7000	8440	10700	52.3	303		219	343	38.6
	TCFL1120	90° 120°	5930	2060	3410	4300	5030	5930	8150	9820	12400		303	373	219	343	
	TCFL1260	60° 90° 120°	6670	2310	3830	4850	5660	6670	9170	11100	14000		303	373	219	343	
	TCFL1480	90° 120°	7830	2720	4500	5690	6650	7830	10800	13000	16400		303	373	219	343	
12	TCFL2070	60° 90°	11000	3800	6300	7960	9300	11000	15100	18200	23000	57.2	432			483	72.6
	TCFL2360	90°	12400	4310	7150	9040	10600	12400	17100	20600	26100		432			483	
	TCFL2510	90° 120°	13300	4610	7630	9660	11300	13300	18300	22000	27800		432	543	323	483	
	TCFL2660	90° 120°	14100	4880	8090	10200	11900	14100	19400	23300	29500		432	543	323	483	
	TCFL2960	90° 120°	15700	5430	9000	11400	13300	15700	21500	26000	32800		432	543	323	483	
	TCFL3250	90°	17200	5960	9880	12500	14600	17200	23700	28500	36100		432			483	

Flow Rate (L<sub>min</sub>) = K (bar)<sup>0.46</sup>

Standard Materials: 316 Stainless Steel

Spray angle performance varies with pressure. Contact BETE for specific data on critical applications.



# WT

HOLLOW CONE

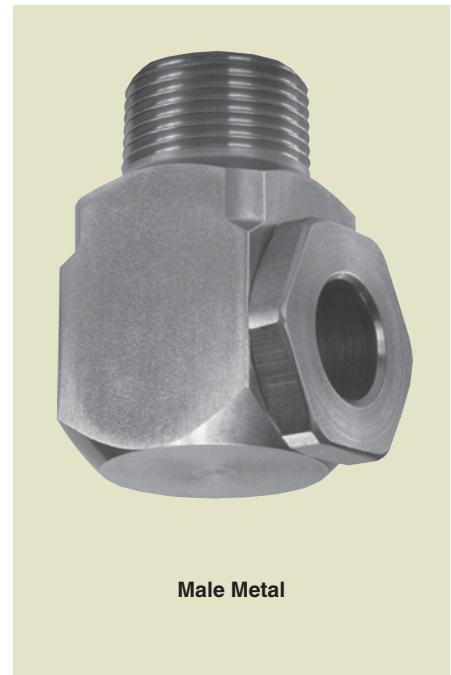

Male Metal

## Right Angle/Hollow Cone

### DESIGN FEATURES

- Conventional design using tangential whirl method of atomization
- Durable
- Use where a circular pattern is required or in large area multiple installations where there is considerable overlapping of sprays
- Male and female connections
- Large free passage

### SPRAY CHARACTERISTICS

**Spray pattern:** Hollow Cone  
**Spray angles:** 70° to 120°  
**Flow rates:** 0.125 to 145 l/min

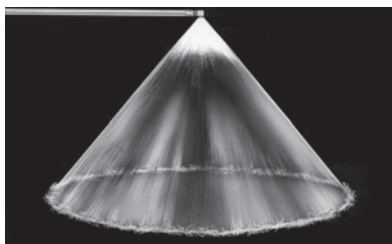

Hollow Cone 80°

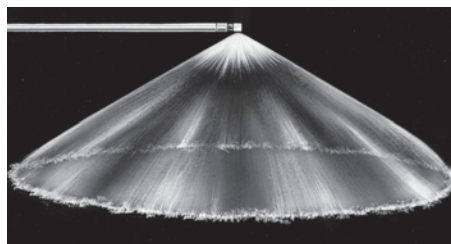

Hollow Cone 120°

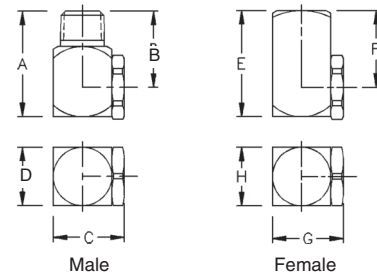

Dimensions are approximate. Check with BETE for critical dimension applications.

### WT Flow Rates and Dimensions

Hollow Cone, Medium and Extra Wide Spray Angles, 1/8" to 3/4" Pipe Sizes, BSP or NPT

Male or Female Pipe Size	Nozzle Number	Spray Angle	K Factor	LITERS PER MINUTE @ BAR								Approx. (mm)		Dimensions for Metal Only (mm)								Wt. (g)	
				0.3 bar	0.5 bar	0.7 bar	1 bar	2 bar	3 bar	5 bar	7 bar	Inlet Dia.	Orifice Dia.	A	B	C	D	E	F	G	H	Metal	Plas.
1/8	WT10	70° 110°	0.228	0.125	0.161	0.191	0.228	0.322	0.395	0.510	0.603	1.02	1.17	28.4	22.4	16.0	12.7	22.4	16.0	16.5	12.7	28	14
	WT20	70° 115°	0.456	0.250	0.322	0.381	0.456	0.645	0.789	1.02	1.21	1.52	1.52										
	WT40	70°	0.912	0.499	0.645	0.763	0.912	1.29	1.58	2.04	2.41	2.29	2.29										
	WT50	115°	1.14	0.624	0.806	0.953	1.14	1.61	1.97	2.55	3.01	2.29	2.29										
	WT60	70° 115°	1.37	0.749	0.967	1.14	1.37	1.93	2.37	3.06	3.62	2.54	2.79										
	WT70	115°	1.60	0.874	1.13	1.33	1.60	2.26	2.76	3.57	4.22	2.54	2.79										
	WT80	120°	1.82	0.999	1.29	1.53	1.82	2.58	3.16	4.08	4.82	2.79	3.05										
	WT100	70° 115°	2.28	1.25	1.61	1.91	2.28	3.22	3.95	5.10	6.03	3.30	3.30										
	WT130	120°	2.96	1.62	2.09	2.48	2.96	4.19	5.13	6.62	7.84	3.56	3.56										
	WT160	70°	3.65	2.00	2.58	3.05	3.65	5.16	6.32	8.15	9.65	3.81	4.06										
WT180	120°	4.10	2.25	2.90	3.43	4.10	5.80	7.10	9.17	10.9	4.32	4.06											
WT200	70°	4.56	2.50	3.22	3.81	4.56	6.45	7.89	10.2	12.1	4.32	4.83											
1/4	WT12	80°	0.273	0.150	0.193	0.229	0.273	0.387	0.474	0.611	0.724	1.02	1.27	33.3	25.4	20.1	16.0	28.4	20.6	20.1	16.0	85	21
	WT18	80°	0.410	0.225	0.290	0.343	0.410	0.580	0.710	0.917	1.09	1.52	1.52										
	WT20	70° 110°	0.456	0.250	0.322	0.381	0.456	0.645	0.789	1.02	1.21	1.52	1.52										
	WT27	80°	0.615	0.337	0.435	0.515	0.615	0.870	1.07	1.38	1.63	1.78	2.03										
	WT35	100°	0.798	0.437	0.564	0.667	0.798	1.13	1.38	1.78	2.11	2.03	2.29										
	WT40	70° 80°	0.912	0.499	0.645	0.763	0.912	1.29	1.58	2.04	2.41	2.03	2.29										
	WT42	120°	0.957	0.524	0.677	0.801	0.957	1.35	1.66	2.14	2.53	2.03	2.29										
	WT48	105°	1.09	0.599	0.773	0.915	1.09	1.55	1.89	2.45	2.89	2.29	2.79										

$$\text{Flow Rate (l/min)} = K \sqrt{\text{bar}}$$

Standard Materials: Brass, 303 Stainless Steel, and 316 Stainless Steel.

Spray angle performance varies with pressure. Contact BETE for specific data on critical applications.

TO ORDER: specify pipe size, connection type, nozzle number, spray angle, and material.

Dimensions are approximate. Check with BETE for critical dimension applications.

**WT Flow Rates and Dimensions**

Hollow Cone, Medium and Extra Wide Spray Angles, 1/8" to 3/4" Pipe Sizes, BSP or NPT

Male or Female Pipe Size	Nozzle Number	Spray Angle	K Factor	LITERS PER MINUTE @ BAR								Approx. (mm)		Dimensions for Metal Only (mm)								Wt. (g)	
				0.3 bar	0.5 bar	0.7 bar	1 bar	2 bar	3 bar	5 bar	7 bar	Inlet Dia.	Orifice Dia.	A	B	C	D	E	F	G	H	Metal	Plas.
1/4	WT53	80°	1.21	0.662	0.854	1.01	1.21	1.71	2.09	2.70	3.20	2.29	2.79	33.3	25.4	20.1	16.0	28.4	20.6	20.1	16.0	85	21
	WT60	70°	1.37	0.749	0.967	1.14	1.37	1.93	2.37	3.06	3.62	2.54	2.79										
	WT68	120°	1.55	0.849	1.10	1.30	1.55	2.19	2.68	3.47	4.10	2.54	3.30										
	WT80	120°	1.82	0.999	1.29	1.53	1.82	2.58	3.16	4.08	4.82	3.30	3.30										
	WT100	70° 115°	2.28	1.25	1.61	1.91	2.28	3.22	3.95	5.10	6.03	3.30	3.56										
	WT130	120°	2.96	1.62	2.09	2.48	2.96	4.19	5.13	6.62	7.84	3.81	4.06										
	WT150	120°	3.42	1.87	2.42	2.86	3.42	4.83	5.92	7.64	9.04	4.06	4.32										
	WT160	70°	3.65	2.00	2.58	3.05	3.65	5.16	6.32	8.15	9.65	4.06	4.32										
	WT180	120°	4.10	2.25	2.90	3.43	4.10	5.80	7.10	9.17	10.9	4.57	4.57										
	WT200	70° 120°	4.56	2.50	3.22	3.81	4.56	6.45	7.89	10.19	12.1	4.57	4.83										
	WT220	120°	5.01	2.75	3.55	4.19	5.01	7.09	8.68	11.2	13.3	4.57	5.59										
	WT240	120°	5.47	3.00	3.87	4.58	5.47	7.73	9.47	12.2	14.5	5.08	5.08										
	WT260	80°	5.93	3.25	4.19	4.96	5.93	8.38	10.3	13.2	15.7	5.08	5.08										
	WT280	80°	6.38	3.49	4.51	5.34	6.38	9.02	11.1	14.3	16.9	5.08	5.59										
	WT300	70° 100°	6.84	3.74	4.83	5.72	6.84	9.67	11.8	15.3	18.1	5.08	5.59										
	WT340	80°	7.75	4.24	5.48	6.48	7.75	11.0	13.4	17.3	20.5	5.59	6.10										
	WT400	80°	9.12	4.99	6.45	7.63	9.12	12.9	15.8	20.4	24.1	6.35	7.11										
	WT480	80°	10.9	5.99	7.73	9.15	10.9	15.5	18.9	24.5	28.9	6.35	6.86										
	WT580	80°	13.2	7.24	9.35	11.1	13.2	18.7	22.9	29.6	35.0	6.86	7.62										
	WT640	80°	14.6	7.99	10.3	12.2	14.6	20.6	25.3	32.6	38.6	6.86	7.62										
WT680	80°	15.5	8.49	11.0	13.0	15.5	21.9	26.8	34.7	41.0	6.86	8.64											
WT800	80°	18.2	9.99	12.9	15.3	18.2	25.8	31.6	40.8	48.2	6.86	8.64											
3/8	WT100	70°	2.28	1.25	1.61	1.91	2.28	3.22	3.95	5.10	6.03	3.56	3.81	38.1	28.4	24.6	19.1	34.0	24.6	19.1	85	21	
	WT130	120°	2.96	1.62	2.09	2.48	2.96	4.19	5.13	6.62	7.84	3.56	4.57										
	WT150	120°	3.42	1.87	2.42	2.86	3.42	4.83	5.92	7.64	9.04	4.32	4.57										
	WT160	70°	3.65	2.00	2.58	3.05	3.65	5.16	6.32	8.15	9.65	4.32	4.57										
	WT180	120°	4.10	2.25	2.90	3.43	4.10	5.80	7.10	9.17	10.9	4.32	4.83										
	WT200	70° 115°	4.56	2.50	3.22	3.81	4.56	6.45	7.89	10.2	12.1	4.83	5.08										
	WT220	120°	5.01	2.75	3.55	4.19	5.01	7.09	8.68	11.2	13.3	4.83	5.08										
	WT240	125°	5.47	3.00	3.87	4.58	5.47	7.73	9.47	12.2	14.5	4.83	5.08										
	WT260	120°	5.93	3.25	4.19	4.96	5.93	8.38	10.3	13.2	15.7	4.83	5.84										
	WT270	120°	6.15	3.37	4.35	5.15	6.15	8.70	10.7	13.8	16.3	5.08	5.84										
	WT300	70° 115°	6.84	3.74	4.83	5.72	6.84	9.67	11.8	15.3	18.1	5.08	5.84										
	WT350	115°	7.98	4.37	5.64	6.67	7.98	11.3	13.8	17.8	21.1	6.10	6.35										
	WT400	70° 105°	9.12	4.99	6.45	7.63	9.12	12.9	15.8	20.4	24.1	6.10	6.86										
	WT440	105°	10.0	5.49	7.09	8.39	10.0	14.2	17.4	22.4	26.5	6.60	7.62										
	WT500	70° 105°	11.4	6.24	8.06	9.53	11.4	16.1	19.7	25.5	30.1	6.60	7.11										
	WT560	105°	12.8	6.99	9.02	10.7	12.8	18.0	22.1	28.5	33.8	6.60	7.87										
WT600	70°	13.7	7.49	9.67	11.4	13.7	19.3	23.7	30.6	36.2	7.87	7.87											
WT1000	70°	22.8	12.5	16.1	19.1	22.8	32.2	39.5	51.0	60.3	8.64	9.65											
1/2	WT500	70°	11.4	6.24	8.06	9.53	11.4	16.1	19.7	25.5	30.1	7.62	7.62	47.5	34.8	31.8	25.4	46.0	33.3	31.8	25.4	276	113
	WT600	70°	13.7	7.49	9.67	11.4	13.7	19.3	23.7	30.6	36.2	8.38	7.87										
	WT800	70°	18.2	9.99	12.9	15.3	18.2	25.8	31.6	40.8	48.2	9.14	9.14										
	WT1000	70° 110°	22.8	12.5	16.1	19.1	22.8	32.2	39.5	51.0	60.3	9.14	11.2										
3/4	WT800	70°	18.2	9.99	12.9	15.3	18.2	25.8	31.6	40.8	48.2	9.14	9.65	57.2	41.1	38.1	31.8	55.6	39.6	38.1	31.8	397	227
	WT1000	70°	22.8	12.5	16.1	19.1	22.8	32.2	39.5	51.0	60.3	10.2	11.2										
	WT1200	70°	27.3	15.0	19.3	22.9	27.3	38.7	47.4	61.1	72.4	11.2	11.2										
	WT1400	80°	31.9	17.5	22.6	26.7	31.9	45.1	55.3	71.3	84.4	11.9	12.2										
	WT1600	80° 115°	36.5	20.0	25.8	30.5	36.5	51.6	63.2	81.5	96.5	12.2	13.0										
	WT1800	80°	41.0	22.5	29.0	34.3	41.0	58.0	71.0	91.7	109	12.7	14.2										
	WT2000	90°	45.6	25.0	32.2	38.1	45.6	64.5	78.9	102	121	13.2	15.0										
	WT2200	90°	50.1	27.5	35.5	41.9	50.1	70.9	86.8	112	133	13.5	16.0										
WT2400	90°	54.7	30.0	38.7	45.8	54.7	77.3	94.7	122	145	14.0	17.5											

Flow Rate ( $l/min$ ) =  $K \sqrt{bar}$

Standard Materials: Brass, 303 Stainless Steel, and 316 Stainless Steel.

Spray angle performance varies with pressure. Contact BETE for specific data on critical applications.



HOLLOW CONE

CALL 413-772-0846  
Call for the name of your nearest BETE representative.

# WTX

HOLLOW CONE

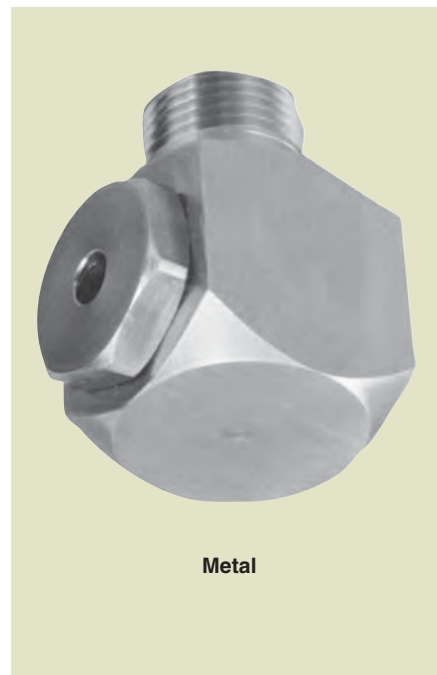

Metal

## Extended Life/Hollow Cone

### DESIGN FEATURES

- Tangential whirl
- Oversized body for extended life
- Male and female connections
- Large free passage

### SPRAY CHARACTERISTICS

**Spray pattern:** Hollow Cone  
**Spray angles:** 70° to 120°  
**Flow rates:** 0.13 to 145 l/min

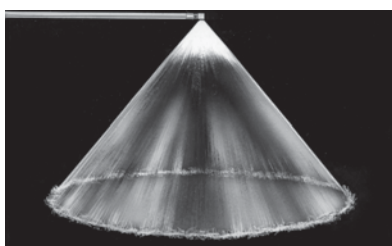

Hollow Cone 80°

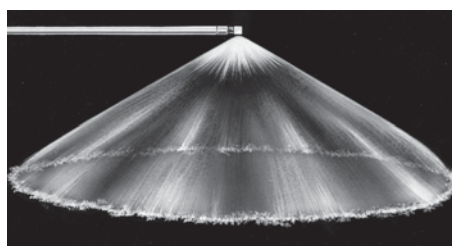

Hollow Cone 120°

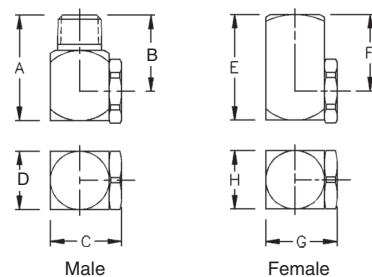

Dimensions are approximate. Check with BETE for critical dimension applications.

### WTX Flow Rates and Dimensions

Hollow Cone, Medium and Extra Wide Spray Angles, 1/8" to 3/4" Pipe Sizes, BSP or NPT

Male or Female Pipe Size	Nozzle Number	Spray Angle	K Factor	LITERS PER MINUTE @ BAR								Approx. (mm)		Dimensions for Metal Only (mm)								Wt. (g) Metal
				0.3 bar	0.5 bar	0.7 bar	1 bar	2 bar	3 bar	5 bar	7 bar	Inlet Dia.	Orifice Dia.	A	B	C	D	E	F	G	H	
1/8	WTX10	70° 110°	0.228	0.125	0.161	0.191	0.228	0.322	0.395	0.510	0.603	1.02	1.17	28.4	22.4	22.4	19.1	25.4	19.1	22.4	19.1	32
	WTX20	70° 115°	0.456	0.250	0.322	0.381	0.456	0.645	0.789	1.02	1.21	1.52	1.52									
	WTX40	70°	0.912	0.499	0.645	0.763	0.912	1.29	1.58	2.04	2.41	2.29	2.29									
	WTX50	115°	1.14	0.624	0.806	0.953	1.14	1.61	1.97	2.55	3.01	2.29	2.29									
	WTX60	70° 115°	1.37	0.749	0.967	1.14	1.37	1.93	2.37	3.06	3.62	2.54	2.79									
	WTX70	115°	1.60	0.874	1.13	1.33	1.60	2.26	2.76	3.57	4.22	2.54	2.79									
	WTX80	120°	1.82	0.999	1.29	1.53	1.82	2.58	3.16	4.08	4.82	2.79	3.05									
	WTX100	70° 115°	2.28	1.25	1.61	1.91	2.28	3.22	3.95	5.10	6.03	3.30	3.30									
	WTX130	120°	2.96	1.62	2.09	2.48	2.96	4.19	5.13	6.62	7.84	3.56	3.56									
	WTX160	70°	3.65	2.00	2.58	3.05	3.65	5.16	6.32	8.15	9.65	3.81	4.06									
	WTX180	120°	4.10	2.25	2.90	3.43	4.10	5.80	7.10	9.17	10.9	4.32	4.06									
WTX200	70°	4.56	2.50	3.22	3.81	4.56	6.45	7.89	10.2	12.1	4.32	4.83										
1/4	WTX12	80°	0.273	0.150	0.193	0.229	0.273	0.387	0.474	0.611	0.724	1.02	1.27	33.3	25.4	22.4	19.1	33.3	25.4	22.4	19.1	74
	WTX18	80°	0.410	0.225	0.290	0.343	0.410	0.580	0.710	0.917	1.09	1.52	1.52									
	WTX20	70° 110°	0.456	0.250	0.322	0.381	0.456	0.645	0.789	1.02	1.21	1.52	1.52									
	WTX27	80°	0.615	0.337	0.435	0.515	0.615	0.870	1.07	1.38	1.63	1.78	2.03									
	WTX35	100°	0.798	0.437	0.564	0.667	0.798	1.13	1.38	1.78	2.11	2.03	2.29									
	WTX40	70° 80°	0.912	0.499	0.645	0.763	0.912	1.29	1.58	2.04	2.41	2.03	2.29									
	WTX42	120°	0.957	0.524	0.677	0.801	0.957	1.35	1.66	2.14	2.53	2.03	2.29									
	WTX48	105°	1.09	0.599	0.773	0.915	1.09	1.55	1.89	2.45	2.89	2.29	2.79									

$$\text{Flow Rate (l/min)} = K \sqrt{\text{bar}}$$

Standard Materials: Brass, 303 Stainless Steel, and 316 Stainless Steel

Spray angle performance varies with pressure. Contact BETE for specific data on critical applications.

TO ORDER: specify pipe size, connection type, nozzle number, spray angle, and material.

Dimensions are approximate. Check with BETE for critical dimension applications.

**WTX Flow Rates and Dimensions**

Hollow Cone, Medium and Extra Wide Spray Angles, 1/8" to 3/4" Pipe Sizes, BSP or NPT

Male or Female Pipe Size	Nozzle Number	Spray Angle	K Factor	LITERS PER MINUTE @ BAR								Approx. (mm)		Dimensions for Metal Only (mm)								Wt. (g) Metal
				0.3 bar	0.5 bar	0.7 bar	1 bar	2 bar	3 bar	5 bar	7 bar	Inlet Dia.	Orifice Dia.	A	B	C	D	E	F	G	H	
1/4	WTX53	80°	1.21	0.662	0.854	1.01	1.21	1.71	2.09	2.70	3.20	2.29	2.79	33.3	25.4	22.2	19.1	33.3	25.4	25.4	19.1	74
	WTX60	70°	1.37	0.749	0.967	1.14	1.37	1.93	2.37	3.06	3.62	2.54	2.79									
	WTX68	120°	1.55	0.849	1.10	1.30	1.55	2.19	2.68	3.47	4.10	2.54	3.30									
	WTX80	120°	1.82	0.999	1.29	1.53	1.82	2.58	3.16	4.08	4.82	3.30	3.30									
	WTX100	70° 115°	2.28	1.25	1.61	1.91	2.28	3.22	3.95	5.10	6.03	3.30	3.56									
	WTX130	120°	2.96	1.62	2.09	2.48	2.96	4.19	5.13	6.62	7.84	3.81	4.06									
	WTX150	120°	3.42	1.87	2.42	2.86	3.42	4.83	5.92	7.64	9.04	4.06	4.32									
	WTX160	70°	3.65	2.00	2.58	3.05	3.65	5.16	6.32	8.15	9.65	4.06	4.32									
	WTX180	120°	4.10	2.25	2.90	3.43	4.10	5.80	7.10	9.17	10.9	4.57	4.57									
	WTX200	70° 120°	4.56	2.50	3.22	3.81	4.56	6.45	7.89	10.19	12.1	4.57	4.83									
	WTX220	120°	5.01	2.75	3.55	4.19	5.01	7.09	8.68	11.2	13.3	4.57	5.59									
	WTX240	120°	5.47	3.00	3.87	4.58	5.47	7.73	9.47	12.2	14.5	5.08	5.08									
	WTX260	80°	5.93	3.25	4.19	4.96	5.93	8.38	10.3	13.2	15.7	5.08	5.08									
	WTX280	80°	6.38	3.49	4.51	5.34	6.38	9.02	11.1	14.3	16.9	5.08	5.59									
	WTX300	70° 100°	6.84	3.74	4.83	5.72	6.84	9.67	11.8	15.3	18.1	5.08	5.59									
	WTX340	80°	7.75	4.24	5.48	6.48	7.75	11.0	13.4	17.3	20.5	5.59	6.10									
	WTX400	80°	9.12	4.99	6.45	7.63	9.12	12.9	15.8	20.4	24.1	6.35	7.11									
	WTX480	80°	10.9	5.99	7.73	9.15	10.9	15.5	18.9	24.5	28.9	6.35	6.86									
	WTX580	80°	13.2	7.24	9.35	11.1	13.2	18.7	22.9	29.6	35.0	6.86	7.62									
	WTX640	80°	14.6	7.99	10.3	12.2	14.6	20.6	25.3	32.6	38.6	6.86	7.62									
WTX680	80°	15.5	8.49	11.0	13.0	15.5	21.9	26.8	34.7	41.0	6.86	8.64										
WTX800	80°	18.2	9.99	12.9	15.3	18.2	25.8	31.6	40.8	48.2	6.86	8.64										
3/8	WTX100	70°	2.28	1.25	1.61	1.91	2.28	3.22	3.95	5.10	6.03	3.56	3.81	38.1	28.4	26.9	22.2	34.0	25.4	24.6	22.2	99
	WTX130	120°	2.96	1.62	2.09	2.48	2.96	4.19	5.13	6.62	7.84	3.56	4.57									
	WTX150	120°	3.42	1.87	2.42	2.86	3.42	4.83	5.92	7.64	9.04	4.32	4.57									
	WTX160	70°	3.65	2.00	2.58	3.05	3.65	5.16	6.32	8.15	9.65	4.32	4.57									
	WTX180	120°	4.10	2.25	2.90	3.43	4.10	5.80	7.10	9.17	10.9	4.32	4.83									
	WTX200	70° 115°	4.56	2.50	3.22	3.81	4.56	6.45	7.89	10.2	12.1	4.83	5.08									
	WTX220	120°	5.01	2.75	3.55	4.19	5.01	7.09	8.68	11.2	13.3	4.83	5.08									
	WTX240	120°	5.47	3.00	3.87	4.58	5.47	7.73	9.47	12.2	14.5	4.83	5.08									
	WTX260	120°	5.93	3.25	4.19	4.96	5.93	8.38	10.3	13.2	15.7	4.83	5.84									
	WTX270	120°	6.15	3.37	4.35	5.15	6.15	8.70	10.7	13.8	16.3	5.08	5.84									
	WTX300	70° 115°	6.84	3.74	4.83	5.72	6.84	9.67	11.8	15.3	18.1	5.08	5.84									
	WTX350	115°	7.98	4.37	5.64	6.67	7.98	11.3	13.8	17.8	21.1	6.10	6.35									
	WTX400	70° 105°	9.12	4.99	6.45	7.63	9.12	12.9	15.8	20.4	24.1	6.10	6.86									
	WTX440	105°	10.0	5.49	7.09	8.39	10.0	14.2	17.4	22.4	26.5	6.60	7.62									
	WTX500	70° 105°	11.4	6.24	8.06	9.53	11.4	16.1	19.7	25.5	30.1	6.60	7.11									
	WTX560	105°	12.8	6.99	9.02	10.7	12.8	18.0	22.1	28.5	33.8	6.60	7.87									
WTX600	70°	13.7	7.49	9.67	11.4	13.7	19.3	23.7	30.6	36.2	7.87	7.87										
WTX1000	70°	22.8	12.5	16.1	19.1	22.8	32.2	39.5	51.0	60.3	8.64	9.65										
1/2	WTX500	70°	11.4	6.24	8.06	9.53	11.4	16.1	19.7	25.5	30.1	7.62	7.62	47.5	34.8	38.1	31.8	47.8	35.1	38.1	31.8	320
	WTX600	70°	13.7	7.49	9.67	11.4	13.7	19.3	23.7	30.6	36.2	8.38	7.87									
	WTX800	70°	18.2	9.99	12.9	15.3	18.2	25.8	31.6	40.8	48.2	9.14	9.14									
	WTX1000	70° 110°	22.8	12.5	16.1	19.1	22.8	32.2	39.5	51.0	60.3	9.14	11.2									
	WTX1200	70°	27.3	15.0	19.3	22.9	27.3	38.7	47.4	61.1	72.4	10.2	12.2									
3/4	WTX800	70°	18.2	9.99	12.9	15.3	18.2	25.8	31.6	40.8	48.2	9.14	9.50	57.2	41.1	44.5	38.1	55.6	39.6	44.5	38.1	460
	WTX1000	70°	22.8	12.5	16.1	19.1	22.8	32.2	39.5	51.0	60.3	10.2	11.2									
	WTX1200	70°	27.3	15.0	19.3	22.9	27.3	38.7	47.4	61.1	72.4	11.2	11.2									
	WTX1400	80°	31.9	17.5	22.6	26.7	31.9	45.1	55.3	71.3	84.4	11.9	12.2									
	WTX1600	80° 115°	36.5	20.0	25.8	30.5	36.5	51.6	63.2	81.5	96.5	12.2	13.0									
	WTX1800	80°	41.0	22.5	29.0	34.3	41.0	58.0	71.0	91.7	109	12.7	14.2									
	WTX2000	90°	45.6	25.0	32.2	38.1	45.6	64.5	78.9	102	121	13.2	15.0									
	WTX2200	90°	50.1	27.5	35.5	41.9	50.1	70.9	86.8	112	133	13.5	16.0									
WTX2400	90°	54.7	30.0	38.7	45.8	54.7	77.3	94.7	122	145	14.0	17.5										

Flow Rate (l/min) = K √ bar

Standard Materials: Brass, 303 Stainless Steel, and 316 Stainless Steel

Spray angle performance varies with pressure. Contact BETE for specific data on critical applications.



HOLLOW CONE

CALL 413-772-0846  
Call for the name of your nearest BETE representative.





HOLLOW CONE

# CW

## Low Flow

### DESIGN FEATURES

- Standard 3-piece construction
- Optional 50- or 100-mesh strainer (refer to page 119 for additional information)
- Protective cover available
- Male and female connections
- Interchangeable spray tips

### SPRAY CHARACTERISTICS

- Spray patterns:** Hollow Cone (H)  
For Full Cone, see page 36
- Spray angles:** 80° and 120°
- Flow rates:** 0.424 to 8.39 l/min

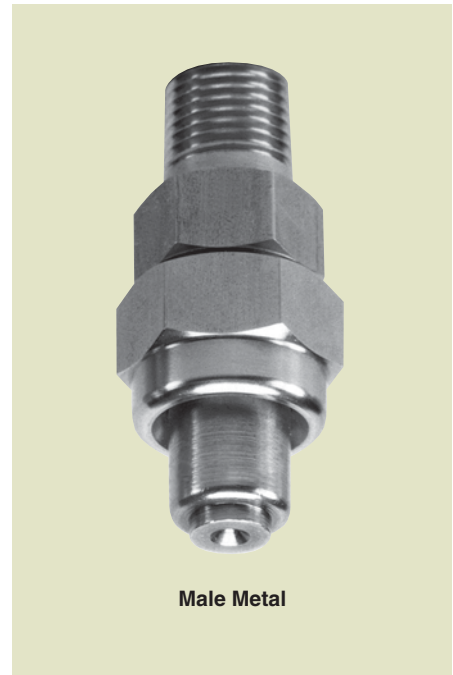

Male Metal

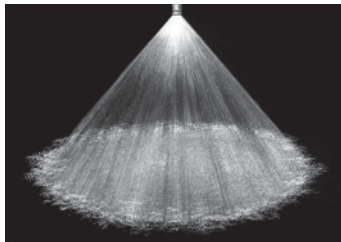

Full Cone 80° (F)

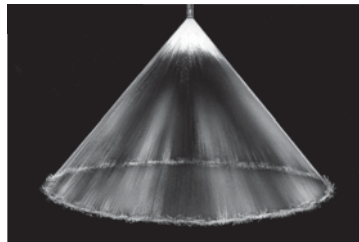

Hollow Cone 80° (H)

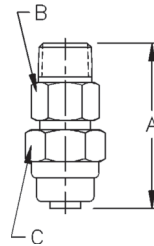

Male

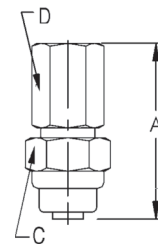

Female

Dimensions are approximate. Check with BETE for critical dimension applications.

### CW Flow Rates and Dimensions

Hollow Cone, 80° and 120° Spray Angles, 1/8" to 3/8" Pipe Sizes, BSP or NPT

Male or Female Pipe Size	Nozzle Number	K Factor	LITERS PER MINUTE @ BAR								Approx. Orifice Dia.(mm)	Male or Female Pipe Size	Dimensions (mm)				Wt. (g) Metal
			0.5 bar	0.7 bar	1 bar	2 bar	3 bar	5 bar	10 bar	15 bar			A	B	C	D	
1/8 or 1/4 or 3/8	CW25-H	0.587	0.424	0.497	0.587	0.814	0.984	1.25	1.73	2.10	1.14	1/8-1/4	52.3	17.5	20.6	17.3	71
	CW50-H	1.17	0.848	0.993	1.17	1.63	1.97	2.50	3.47	4.19	1.37						
	CW75-H	1.76	1.27	1.49	1.76	2.44	2.95	3.75	5.20	6.29	1.60	3/8	52.3	17.5	20.6	20.6	
	CW100-H	2.35	1.70	1.99	2.35	3.25	3.94	5.01	6.93	8.39	2.18						

$$\text{Flow Rate (l/min)} = K (\text{bar})^{0.47}$$

Standard Materials: Brass, 303 Stainless Steel, and 316 Stainless Steel

Spray angle performance varies with pressure. Contact BETE for specific data on critical applications.

TO ORDER: specify pipe size, connection type, nozzle number, spray angle, and material.

# TF

## Wide Range of Flows and Angles

### DESIGN FEATURES

- The original spiral nozzle invented by BETE and continuously improved!
- High energy efficiency
- One-piece/no internal parts
- Clog-resistant performance
- High discharge velocity
- Male connection standard; female connection available by special order

### SPRAY CHARACTERISTICS

- Wide range of flow rates and spray angles
- Fine atomization

**Spray patterns:** Hollow Cone

For Full Cone, see page 28

**Spray angles:** 50° to 180°

**Flow rates:** 2.26 to 10700 L/min  
(Higher flow rates available)

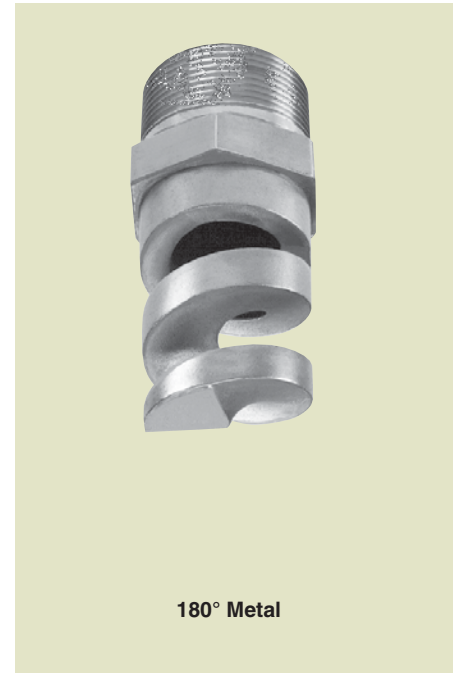

HOLLOW CONE



Hollow Cone 50° (N)

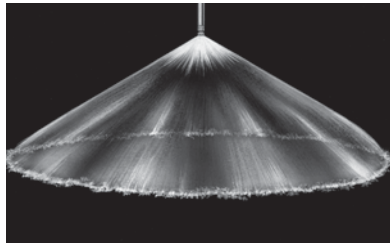

Hollow Cone 120° (W)

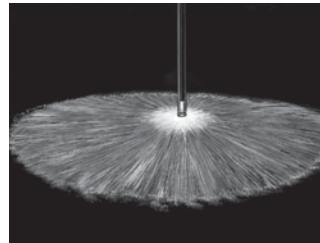

Hollow Cone 180° (XW)

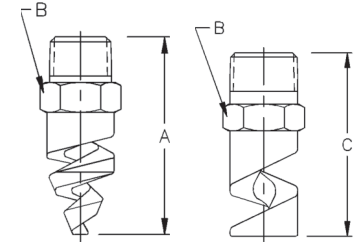

50°, 60°, 90°, 120°

180°

Dimensions are approximate. Check with BETE for critical dimension applications

### TF Hollow Cone Flow Rates and Dimensions

Hollow Cone, 50° (N), 60° (V), 90° (M), 120° (W), and 180° (XW) Spray Angles, 1/4" to 4" Pipe Sizes, BSP or NPT

Male Pipe Size	Nozzle Number	Available Spray Angles					K Factor	LITERS PER MINUTE @ BAR					PTFE not recommended at pressures above red line			Approx. (mm)		Dim. (mm) for Metal Only*			Wt. (g)			
		50°	60°	90°	120°	180°		0.5 bar	0.7 bar	1 bar	2 bar	3 bar	5 bar	10 bar	20 bar	Orif. Dia.	Free Pass. Dia.	A	B	C	180° Metal	Plas.		
1/4	TF6	50°	60°	90°	120°	180°	3.19	2.26	2.67	3.19	4.5	5.5	7.1	10.1	14.3	2.38	2.38	42.9	14.3					
	TF8	50°	60°	90°	120°	180°	5.93	4.19	4.96	5.93	8.4	10.3	13.2	18.7	26.5	3.18	3.18	47.6	14.3	47.6	35	21		
	TF10	50°	60°	90°	120°	180°	9.12	6.45	7.63	9.12	12.9	15.8	20.4	28.8	40.8	3.97	3.18	47.6	14.3	47.6				
3/8	TF12	50°	60°	90°	120°	180°	13.7	9.7	11.4	13.7	19.3	23.7	30.6	43.2	61.1	4.76	3.18							
	TF14	50°	60°	90°	120°	180°	18.5	13.1	15.4	18.5	26.1	32.0	41.3	58.4	82.6	5.56	3.18	47.6	17.5 <sup>1</sup>	47.6	50	21		
	TF16	50°	60°	90°	120°	180°	24.2	17.1	20.2	24.2	34.2	41.8	54.0	76.4	108	6.35	3.18							
1/2	TF20	50°	60°	90°	120°	180°	37.6	26.6	31.5	37.6	53.2	65.1	84.1	119	168	7.94	3.18							
	TF24	50°	60°	90°	120°	180°	54.9	38.8	46.0	54.9	77.7	95.1	123	174	246	9.53	4.76	63.5	22.2	60.5	85	25		
3/4	TF28	50°	60°	90°	120°	180°	75.2	53.2	62.9	75.2	106	130	168	238	336	11.1	4.76							
	TF32	50°	60°	90°	120°	180°	95.7	67.7	80.1	95.7	135	166	214	303	428	12.7	4.76	69.9	28.6	76.2	85	28		
1	TF40	60°	90°	120°	180°		153	108	128	153	216	264	341	483	683	15.9	6.35	92.1	34.9	92.2	425	85		
	TF48	60°	90°	120°	180°		217	153	181	216	306	375	484	685	968	19.1	6.35							
1 1/2	TF56	60°	90°	120°	180°		294	208	246	294	416	509	657	930	1320	22.2	7.94							
	TF64	60°	90°	120°	180°		385	272	322	385	545	667	861	1220	1720	25.4	7.94	111	50.8	111	851	170		
	TF72	60°	90°	120°	180°		438	309	366	438	619	758	978	1380	1960	28.6	7.94							
2	TF88	60°	90°	120°	180°		638	451	534	638	902	1110	1430	2020	2850	34.9	11.1	143	63.5	127	1300	227		
	TF96	60°	90°	120°	180°		806	570	674	806	1140	1400	1800	2550	3600	38.1	11.1	176	63.5	127	1530	255		
3	TF112	60°	90°	120°			1170	825	976	1170	1650	2020	2610	3690	5220	44.5	14.3	219	88.9					
	TF128	60°	90°	120°			1550	1090	1290	1550	2190	2680	3460	4891	6920	50.8	14.3							
4	TF160	60°	90°	120°			2390	1690	2000	2390	3380	4140	5350	7570	10700	63.5	15.9	257	114					

Flow Rate ( $l_{min}$ ) =  $K \sqrt{\text{bar}}$  \*Dimensions are for bar stock, cast sizes may vary. <sup>1</sup> 25.4 mm for 180°

Standard Materials: Brass, 316 Stainless Steel, PVC, Polypropylene, and PTFE (Poly. not available for TF6 - TF10)

TF8 and TF 24 150° are Factory Mutual approved. Contact BETE for more information.

Spray angle performance varies with pressure. Contact BETE for specific data on critical applications.

# EZ<sub>TF</sub> WT

## EZ Change Quick Connection System

### DESIGN FEATURES

- Nozzles can be changed in seconds without tools
- Three part nozzle, base, gasket and interchangeable tip
- Exclusive ramped engagement for efficient automatic alignment
- Threaded adapters will accommodate other standard BETE nozzles. Shut-off plugs are also available

### SPRAY CHARACTERISTICS

- Available in six standard tips: EZTF; EZWL; EZWT; EZFF; EZNF; EZSPN

#### More EZ tips:

- Full Cone: page 38
- Flat Fan: pages 72 and 73

**Flow rates:** 0.13 to 206 l/min

#### Spray Angles:

- EZTF:** 60°, 90°, 120°, and 180°
- EZWT:** 70° and 110°



EZTF

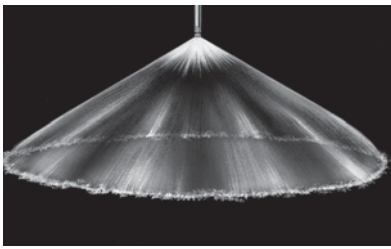

120° Hollow Cone

Dimensions are approximate. Check with BETE for critical dimension applications.

### EZTF Flow Rates and Dimensions

Hollow Cone Spiral 60° (V), 90° (M), 120° (W), 150°, 170° or 180° (XW) Spray Angle 1/8" to 1/2" BSP or NPT

Pipe Size	Nozzle Number	K Factor	LITERS PER MINUTE @ BAR													Approx. Orifice Dia. (mm)	Approx. Assembly Dim. (mm)		Wt. (g)
			0.3 bar	0.5 bar	0.7 bar	1 bar	2 bar	3 bar	5 bar	7 bar	10 bar	15 bar	20 bar	30 bar	Hex Length				
1/8"	EZTF6	3.19	1.75	2.26	2.67	3.19	4.51	5.53	7.13	8.44	10.1	12.4	14.3	17.5	2.38	1/8"	22.4	41.4	62
	EZTF8	5.93	3.25	4.19	4.96	5.93	8.38	10.3	13.2	15.7	18.7	22.9	26.5	32.5	3.18				
1/2"	EZTF10	9.12	4.99	6.45	7.63	9.12	12.9	15.8	20.4	24.1	28.8	35.3	40.8	49.9	3.97	1/4"	22.4	44.5	62
	EZTF12	13.7	7.49	9.7	11.4	13.7	19.3	23.7	30.6	36.2	43.2	53.0	61.1	74.9	4.76				
1/4"	EZTF14	18.5	10.1	13.1	15.4	18.5	26.1	32.0	41.3	48.8	58.4	71.5	82.6	101	5.56	3/8"	22.4	46.0	74
	EZTF16	24.2	13.2	17.1	20.2	24.2	34.2	41.8	54.0	63.9	76.4	93.6	108	132	6.35				
1/2"	EZTF20	37.6	20.6	26.6	31.5	37.6	53.2	65.1	84.1	99.5	119	146	168	206	7.94	1/2"	22.4	47.5	82

Flow Rate (l/min) =  $K \sqrt{\text{bar}}$

TF20 not available with 1/8" base

Standard Materials: Brass, Viton and Buna-N gaskets standard. 316 Stainless Steel available upon request.

Spray angle performance varies with pressure. Contact BETE for specific data on critical applications.

TO ORDER: specify pipe size, connection type, nozzle number, spray angle, and material.

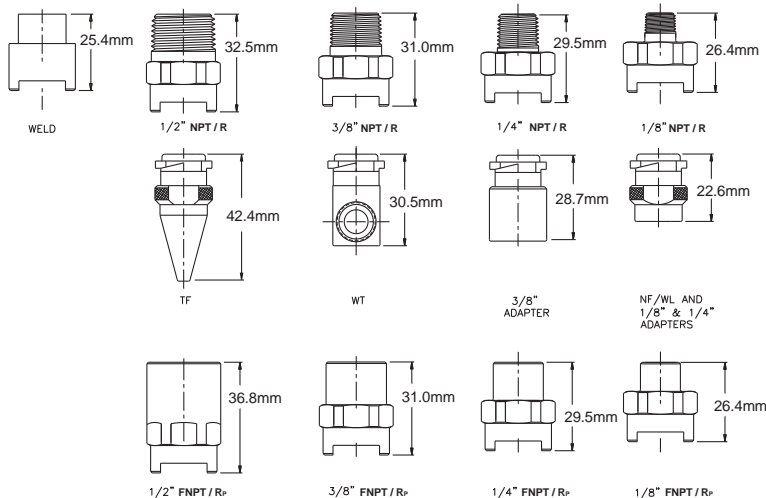

Dimensions are approximate. Check with BETE for critical dimension applications.

### EZWT Flow Rates and Dimensions

Hollow Cone, Narrow (70°) and Wide (110°) Spray Angles 1/8" to 1/2" BSP or NPT

Pipe Size	Nozzle Number	K Factor	LITERS PER MINUTE @ BAR											Orifice Dia. (mm)	Approx. Assembly Dim. (mm)		Wt. (g)		
			0.3 bar	0.5 bar	0.7 bar	1 bar	2 bar	3 bar	5 bar	7 bar	10 bar	15 bar	20 bar		30 bar	Hex Length		Hex Length	
1/8"	EZWT10	0.228	0.13	0.16	0.19	0.23	0.32	0.40	0.51	0.60	0.72	0.88	1.02	1.25	0.794	1/8"	22.4	41.4	62
	EZWT12	0.273	0.15	0.19	0.23	0.27	0.39	0.47	0.61	0.72	0.87	1.06	1.22	1.50	0.794				
	EZWT18	0.410	0.23	0.29	0.34	0.42	0.58	0.71	0.92	1.09	1.30	1.59	1.83	2.25	1.19				
	EZWT20	0.456	0.25	0.32	0.38	0.46	0.65	0.79	1.02	1.21	1.44	1.77	2.04	2.50	1.59				
	EZWT27	0.615	0.34	0.44	0.52	0.62	0.87	1.07	1.38	1.63	1.95	2.38	2.75	3.37	1.19				
	EZWT35	0.798	0.44	0.56	0.67	0.80	1.13	1.38	1.78	2.11	2.52	3.09	3.57	4.37	1.59				
	EZWT40	0.912	0.50	0.65	0.76	0.91	1.29	1.58	2.04	2.41	2.88	3.53	4.08	4.99	1.98				
	EZWT42	0.957	0.52	0.68	0.80	0.96	1.35	1.66	2.14	2.53	3.03	3.71	4.28	5.24	1.59				
	EZWT48	1.09	0.60	0.77	0.92	1.09	1.55	1.89	2.45	2.89	3.46	4.24	4.89	5.99	1.59				
	EZWT50	1.14	0.62	0.81	0.95	1.14	1.61	1.97	2.55	3.01	3.60	4.41	5.10	6.24	1.98				
TO	EZWT53	1.21	0.66	0.85	1.01	1.21	1.71	2.09	2.70	3.20	3.82	4.68	5.40	6.62	1.98	1/4"	22.4	44.5	62
	EZWT60	1.37	0.75	0.97	1.14	1.37	1.93	2.37	3.06	3.62	4.32	5.30	6.11	7.49	2.38				
	EZWT68	1.55	0.85	1.10	1.30	1.55	2.19	2.68	3.47	4.10	4.90	6.00	6.93	8.49	1.98				
	EZWT70	1.60	0.87	1.13	1.33	1.60	2.26	2.76	3.57	4.22	5.04	6.18	7.13	8.74	2.38				
	EZWT80	1.82	1.00	1.29	1.53	1.82	2.58	3.16	4.08	4.82	5.77	7.06	8.15	9.99	1.98				
	EZWT100	2.28	1.25	1.61	1.91	2.28	3.22	3.95	5.10	6.03	7.21	8.83	10.2	12.5	3.18				
	EZWT130	2.96	1.62	2.09	2.48	2.96	4.19	5.13	6.62	7.84	9.37	11.5	13.2	16.2	3.18				
	EZWT150	3.42	1.87	2.42	2.86	3.42	4.83	5.92	7.64	9.04	10.8	13.2	15.3	18.7	3.57				
	EZWT160	3.65	2.00	2.58	3.05	3.65	5.16	6.32	8.15	9.65	11.5	14.1	16.3	20.0	3.97				
	EZWT180	4.10	2.25	2.90	3.43	4.10	5.80	7.10	9.17	10.9	13.0	15.9	18.3	22.5	3.97				
1/2"	EZWT200	4.56	2.50	3.22	3.81	4.56	6.45	7.89	10.2	12.1	14.4	17.7	20.4	25.0	4.37	1/2"	22.4	47.5	82
	EZWT220	5.01	2.75	3.55	4.19	5.01	7.09	8.68	11.2	13.3	15.9	19.4	22.4	27.5	3.97				
	EZWT240	5.47	3.00	3.87	4.58	5.47	7.73	9.47	12.2	14.5	17.3	21.2	24.5	30.0	4.76				
	EZWT260	5.93	3.25	4.19	4.96	5.93	8.38	10.3	13.2	15.7	18.7	22.9	26.5	32.5	5.16				
	EZWT270	6.15	3.37	4.35	5.15	6.15	8.70	10.7	13.8	16.3	19.5	23.8	27.5	33.7	5.16				
	EZWT280	6.38	3.49	4.51	5.34	6.38	9.02	11.1	14.3	16.9	20.2	24.7	28.5	34.9	5.56				
	EZWT300	6.84	3.74	4.83	5.72	6.84	9.67	11.8	15.3	18.1	21.6	26.5	30.6	37.4	5.56				
	EZWT340	7.75	4.24	5.48	6.48	7.75	11.0	13.4	17.3	20.5	24.5	30.0	34.7	42.4	5.56				
	EZWT350	7.98	4.37	5.64	6.67	7.98	11.3	13.8	17.8	21.1	25.2	30.9	35.7	43.7	5.95				
	EZWT400	9.12	4.99	6.45	7.63	9.12	12.9	15.8	20.4	24.1	28.8	35.3	40.8	49.9	7.14				

$$\text{Flow Rate (l/min)} = K \sqrt{\text{bar}}$$

Standard Materials: 303 Stainless Steel, 316 Stainless Steel, Brass, Viton gaskets standard.

HOLLOW CONE

CALL 413-772-0846  
Call for the name of your nearest BETE representative.



# SF

## Snap Release Nozzle System

### DESIGN FEATURES

- Nozzles can be quickly changed and aligned by hand without tools
- Clamp-on adapter fits any style nozzle
- Quick set-up system features special "Snap-in" tips
- Polypropylene, resistant to most acids and alkalis
- Double clamp base or adapter available for higher pressure operation

### SPRAY CHARACTERISTICS

- Quick Set-up System can be provided with fan, hollow or full cone spray tips
- Full 45° alignment of spray without tools

### More SF Nozzle Systems:

Full Cone: page 39

Flat Fan: page 74

**Flow rates:** 2.42 - 72.1 l/min

### Spray angles:

**Fan:** 40°, 50°, 65°, 80°, 95°

**Hollow Cone:** 50°, 65°, 90°

**Full Cone:** 35°, 65°, 80°

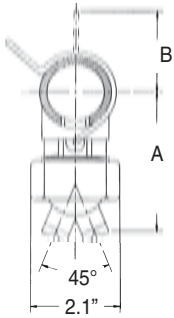
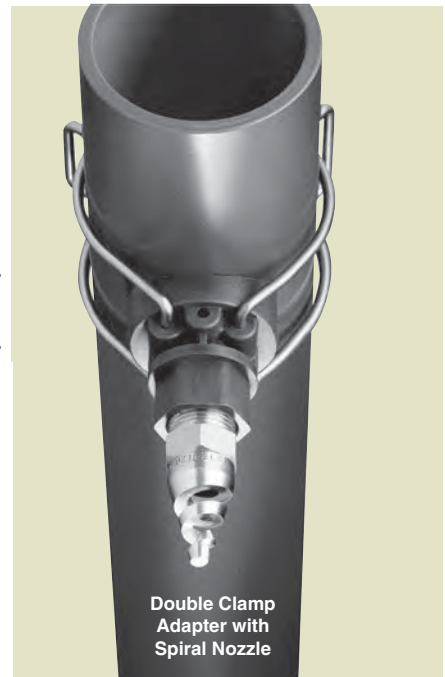

### CLAMP-ON ADAPTER

- Available for 1", 1-1/4", 1-1/2" and 2" pipe.
- Available with 1/8", 1/4", 3/8", 1/2" NPT female threads; or 1/8" BSP female threads
- Available with single or double clamp.
- **TO ORDER ADAPTER Specify: Pipe Size, thread size, thread type, number of clamps, materials.**

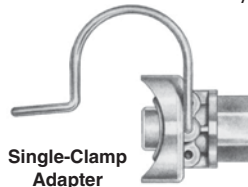
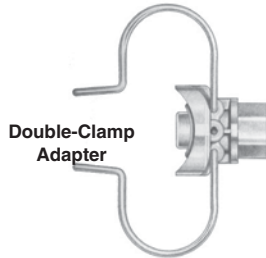

### "SNAP-IN" Hollow Cone Nozzle Tip

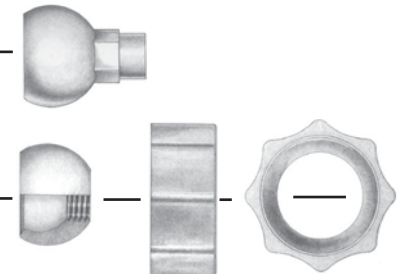

**"SNAP-IN" Threaded Swivel Ball**  
Available with 1/8", 1/4", 3/8", 1/2" NPT or BSP Female threads

Dimensions are approximate. Check with BETE for critical dimension applications.

### SF Flow Rates and Dimensions

SF Hollow Cone 50°, 65° and 90° Spray Angles 1", 1-1/4", 1-1/2" and 2"

Nozzle Number	Available Spray Angle	K Factor	LITERS PER MINUTE @ BAR								Pipe Size	Body Color	Approx. Dim. (mm)		Wt. (g)
			0.5 bar	0.7 bar	1 bar	2 bar	3 bar	5 bar	7 bar	10 bar			A	B	
SF15HC	90°	3.416	2.42	2.86	3.42	4.83	5.92	7.64	9.04	10.8	1"	blue	83.8	43.2	62.4
SF58HC	50°	13.22	9.35	11.1	13.2	18.7	22.9	29.6	35.0	41.8	1-1/4"	red	86.4	48.3	62.4
SF100HC	65°	22.79	16.1	19.1	22.8	32.2	39.5	51.0	60.3	72.1	1-1/2"	purple	91.4	50.8	62.4
											2"	green	94.0	55.9	62.4

$$\text{Flow Rate (l/min)} = K \sqrt{\text{bar}}$$

**Standard Materials:** Polypropylene, 302 Stainless Steel clamp, EPDM seal.

**Optional Materials:** 303 Stainless Steel clamp, Viton seal.

**NOTE:** Drill 16.7mm (21/32") hole in pipe to install SF.

**NOTE:** Maximum recommended pressures for SF assemblies: With single clamp 5 bar for 1" pipe; 3.5 bar for 1-1/4" and 1-1/2" pipe; and 2 bar for 2" pipe; with double clamp up to 10 bar.

# NCJ

## Hollow Cone/Narrow Angle Injector

### DESIGN FEATURES

- Narrow spray angles
- High velocity
- Male and female connections
- Flanged connections available
- Available in plastic and metal alloys

### SPRAY CHARACTERISTICS

- Spray is coarse and extremely hard-driving
- Spray pattern:** Hollow Cone  
**Spray angles:** 15°, 20°, and 30°  
**Flow rates:** 23.1 to 4660 L/min  
 (Special flow rates available)

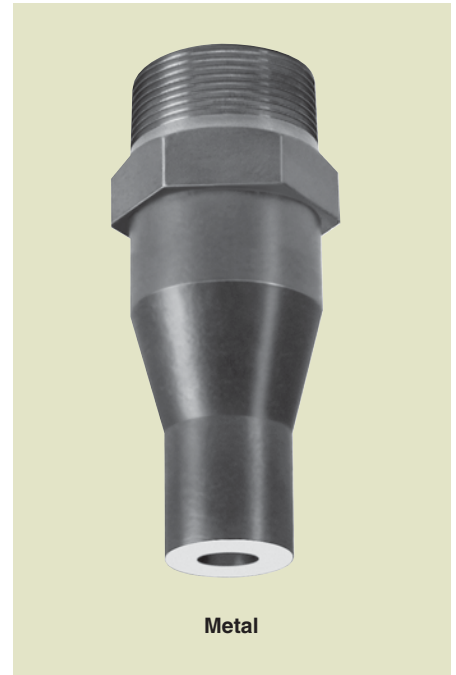

HOLLOW CONE

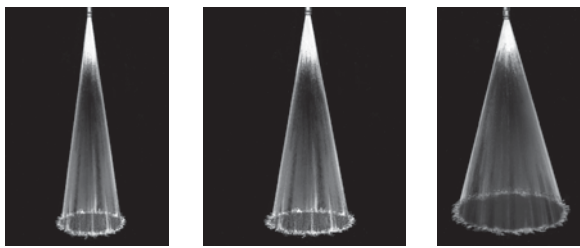

Hollow Cone 15°

Hollow Cone 20°

Hollow Cone 30°

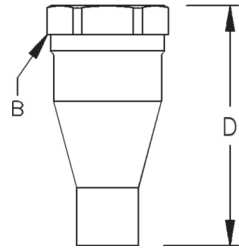

Female

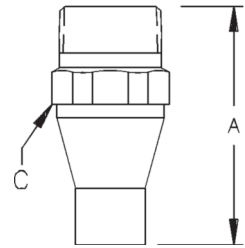

Male

Dimensions are approximate. Check with BETE for critical dimension applications.

### NCJ Flow Rates and Dimensions

Hollow Cone, 15°, 20°, and 30° Spray Angles, 3/4" to 6" Pipe Sizes, BSP or NPT

Male or Female Pipe Size	Nozzle Number	K Factor	LITERS PER MINUTE @ BAR								Approx. Orifice Dia. (mm)	Dimensions for Metal Only (mm)				Wt. (kg)	
			0.5 bar	0.7 bar	1 bar	1.5 bar	2 bar	3 bar	5 bar	7 bar		A	B	C	D	PVC	Metal
3/4	NC 0706J	32.0	23.1	27.0	32.0	38.7	44.3	53.6	68.1	79.8	7.52	82.6	34.9	28.4	82.6	0.04	0.34
1	NC 1012J	64.0	46.2	54.1	64.0	77.4	88.6	107	136	160	10.3	88.9	44.5	35.1	88.9	0.06	0.45
1 1/4	NC 1218J	95.9	69.3	81.1	95.9	116	133	161	204	239	12.3	102	50.8	44.5	102	0.11	0.57
1 1/2	NC 1526J	139	100	117	139	168	192	232	295	346	15.1	127	63.5	50.8	127	0.20	1.02
2	NC 2048J	256	185	216	256	310	354	429	545	638	20.2	152	76.2	63.5	152	0.37	1.13
2 1/2	NC 2572J	384	277	325	384	464	532	643	818	958	24.6	178	82.6	76.2	194	0.62	2.61
3	NC 30105J	560	404	473	560	677	775	938	1190	1400	29.5	203	97.5	88.9	203	0.85	2.84
4	NC 40190J	1010	731	856	1010	1230	1400	1700	2160	2530	40.5	251	127	114	278	2.04	6.80
6	NC 60350J	1860	1380	1580	1860	2260	2580	3130	3980	4660	54.0	343	181	168	381	2.78	15.9

$$\text{Flow Rate (L/min)} = K (\text{bar})^{0.47}$$

Standard Materials: Brass, 316 Stainless Steel, PVC, Polypropylene, and PTFE

NOTE for PTFE nozzles: if operating temperature is to exceed 150 °C or the operating pressure is to exceed the values listed in the table above, please contact BETE Applications Engineering for assistance.

Spray angle performance varies with pressure. Contact BETE for specific data on critical applications.

CALL 413-772-0846  
 Call for the name of your nearest BETE representative.



HOLLOW CONE

# TH

## Tangential Inlet/Right Angle

### DESIGN FEATURES

- Large free passage
- Clog-resistant; nozzles have no internal parts
- One-piece construction
- Female connection
- Flanged connection available
- Silicon carbide available upon request
- Inlet and outlet are in-line

### SPRAY CHARACTERISTICS

- Patented geometry designed to give the most uniform liquid distribution around the periphery of the spray.

**Spray pattern:** Hollow Cone

**Spray angles:** Narrow to Medium

**Flow rates:** 15.3 to 2230 l/min

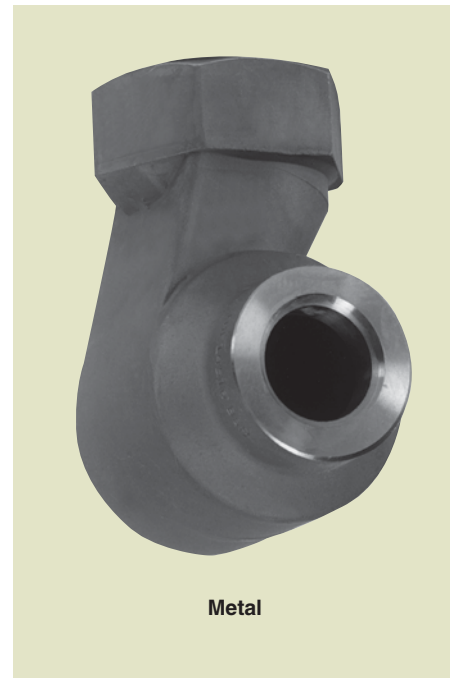

Metal

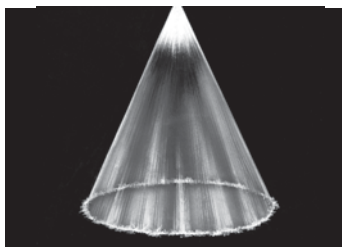

Hollow Cone - Narrow Angle

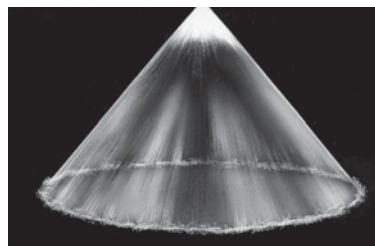

Hollow Cone - Medium Angle

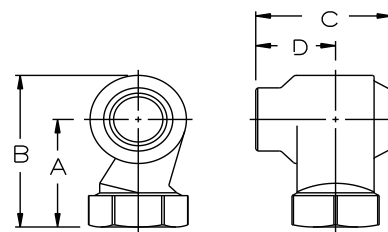

Dimensions are approximate. Check with BETE for critical dimension applications.

### TH Flow Rates and Dimensions

Hollow Cone, Narrow to Medium Spray Angles, 1" to 3" Pipe Sizes, BSP or NPT

Female Pipe Size	Nozzle Number	Spray Ang.				K Factor	LITERS PER MINUTE @ BAR							Approx. Orifice Dia. (mm)	Free Pass. Dia. (mm)	Dimensions (mm) (MAX)				Wt. (kg)
		0.3 bar	1 bar	3 bar			0.2 bar	0.3 bar	0.5 bar	0.7 bar	1 bar	1.5 bar	2 bar			3 bar	A	B	C	
1	THF1508	54°	54°	54°	34.2	15.3	18.7	24.2	28.6	34.2	41.9	48.3	59.2	8.73	8.73	58.7	79.5	63.3	39.4	0.47
	THF1808	56°	56°	56°	41.0	18.3	22.5	29.0	34.3	41.0	50.2	58.0	71.0	9.53	9.53					
	THF2308	63°	66°	66°	52.4	23.4	28.7	37.1	43.9	52.4	64.2	74.1	90.8	11.1	11.1					
	THF2708	66°	70°	70°	61.5	27.5	33.7	43.5	51.5	61.5	75.4	87.0	107	11.9	11.9					
	THF3208	68°	72°	71°	72.9	32.6	39.9	51.6	61.0	72.9	89.3	103	126	13.9	13.9					
	THF 3808	68°	72°	71°	86.6	38.7	47.4	61.2	72.5	86.6	106	122	150	15.2	15.2					
1 1/4	THF3210	66°	66°	66°	72.9	32.6	39.9	51.6	61.0	72.9	89.3	103	126	13.9	13.9	74.2	99.3	75.4	46.7	0.75
	THF3810	68°	70°	70°	86.6	38.7	47.4	61.2	72.5	86.6	106	122	150	15.9	15.9					
	THF4110	73°	74°	74°	93.4	41.8	51.2	66.1	78.2	93.4	114	132	162	16.7	16.7					
	THF5210	90°	90°	90°	119	53.0	64.9	83.8	99.1	119	145	168	205	19.8	19.8					
	THF7010	83°	85°	85°	160	71.3	87.4	113	133	160	195	226	276	26.2	22.6					
1 1/2	THF6112	58°	60°	60°	139	62.2	76.1	98	116	139	170	197	241	19.4	19.4	75.7	105	92.0	57.9	0.85
	THF7012	63°	65°	65°	160	71.3	87.4	113	133	160	195	226	276	21.4	21.4					
	THF7712	63°	66°	66°	175	78.5	96.1	124	147	175	215	248	304	23.4	23.4					
	THF9012	67°	70°	70°	205	91.7	112	145	172	205	251	290	355	26.2	26.2					
	THF12712	75°	80°	80°	289	129	159	205	242	289	354	409	501	32.9	27.0					
	THF14512	80°	80°	83°	330	148	181	234	276	330	405	467	572	36.1	27.0					

Flow Rate (l/min) = K√bar

Standard Materials: Brass, Carbon Steel, and 316 Stainless Steel

Spray angle performance varies with pressure. Contact BETE for specific data on critical applications.

TO ORDER: specify pipe size, connection type, nozzle number, spray angle, and material.



Silicon Carbide, Flanged



HOLLOW CONE

Dimensions are approximate. Check with BETE for critical dimension applications.

**TH Flow Rates and Dimensions**

Hollow Cone, Narrow to Medium Spray Angles, 1" to 3" Pipe Sizes, BSP or NPT

Female Pipe Size	Nozzle Number	Spray Ang.			K Factor	LITERS PER MINUTE @ BAR								Approx. Orifice Dia. (mm)	Free Pass. Dia. (mm)	Dimensions (mm) (MAX)				Wt. (kg)
		0.3 bar	1 bar	3 bar		0.2 bar	0.3 bar	0.5 bar	0.7 bar	1 bar	1.5 bar	2 bar	3 bar			A	B	C	D	
2	THF8516	63°	65°	65°	194	86.6	106	137	162	194	237	274	336	21.8	21.8	93.2	132	109	64.5	1.43
	THF10516	65°	67°	67°	239	107	131	169	200	239	293	338	414	25.4	25.4					
	THF12516	68°	70°	70°	285	127	156	201	238	285	349	403	493	29.0	29.0					
	THF14516	74°	79°	79°	330	148	181	234	276	330	405	467	572	32.1	32.1					
	THF17016	77°	80°	80°	387	173	212	274	324	387	474	548	671	35.3	35.3					
	THF19216	77°	80°	80°	438	196	240	309	366	438	536	619	758	38.5	36.5					
	THF20516	77°	83°	83°	467	209	256	330	391	467	572	661	809	41.3	36.5					
	THF23016	76°	83°	83°	524	234	287	371	439	524	642	741	908	44.5	36.5					
2 1/2	THF17020	85°	85°	85°	387	173	212	274	324	387	474	548	671	33.7	33.7	126	173	143	88.1	2.94
	THF19020	70°	73°	73°	433	194	237	306	362	433	530	612	750	36.1	36.1					
	THF20520	72°	75°	73°	467	209	256	330	391	467	572	661	809	37.3	37.3					
	THF23020	76°	78°	78°	524	234	287	371	439	524	642	741	908	40.1	40.1					
	THF28020	79°	80°	80°	638	285	349	451	534	638	781	902	1105	46.0	44.5					
	THF32020	83°	85°	85°	729	326	399	516	610	729	893	1031	1263	51.2	44.5					
	THF34020	87°	90°	90°	775	347	424	548	648	775	949	1096	1342	53.2	44.5					
	THF43520	92°	95°	95°	991	443	543	701	829	991	1214	1402	1717	61.9	44.5					
3	THF18524	58°	58°	58°	422	189	231	298	353	422	516	596	730	32.5	32.5	146	201	162	99.0	4.03
	THF23024	65°	65°	65°	524	234	287	371	439	524	642	741	908	36.5	36.5					
	THF28024	70°	70°	70°	638	285	349	451	534	638	781	902	1110	41.3	41.3					
	THF32024	65°	70°	70°	729	326	399	516	610	729	893	1030	1260	45.2	45.2					
	THF34024	68°	70°	70°	775	347	424	548	648	775	949	1100	1340	46.8	46.8					
	THF41224	75°	78°	78°	939	420	514	664	786	939	1150	1330	1630	53.6	53.6					
	THF46924	75°	80°	80°	1070	478	585	756	894	1070	1310	1510	1850	57.9	54.0					
	THF52624	78°	80°	80°	1200	536	657	848	1000	1200	1470	1700	2080	63.1	54.0					
THF56424	78°	80°	80°	1290	575	704	909	1080	1290	1570	1820	2230	65.9	54.0						

Flow Rate ( $l/min$ ) =  $K\sqrt{bar}$

Standard Materials: Brass, Carbon Steel, and 316 Stainless Steel

Spray angle performance varies with pressure. Contact BETE for specific data on critical applications.

CALL 413-772-0846  
Call for the name of your nearest BETE representative.



# THIW



HOLLOW CONE

## Tangential Inlet/Wide Spray Band

### DESIGN FEATURES

- Large free passage
- Clog-resistant; nozzles have no internal parts
- Wide spray band
- Female connection
- Flanged connection available
- Silicon carbide available upon request
- Inlet and outlet are in-line

### SPRAY CHARACTERISTICS

- Spray pattern:** Hollow Cone
- Spray angle:** Wide
- Flow rates:** 15.3 to 2230 l/min

Metal

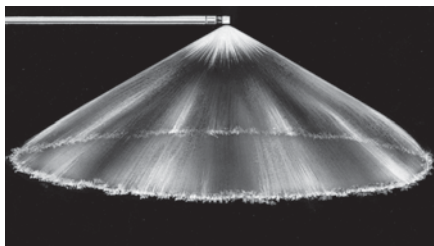

Hollow Cone - Wide Angle

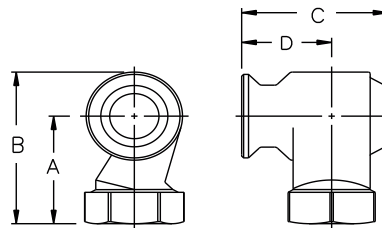

Dimensions are approximate. Check with BETE for critical dimension applications.

### THW Flow Rates and Dimensions

Hollow Cone, Wide Spray Angles, 1" to 3" Pipe Sizes, BSP or NPT

Female Pipe Size	Nozzle Number	Spray Angles			K Factor	LITERS PER MINUTE @ BAR								Approx. Orifice Dia. (mm)	Free Pass. Dia. (mm)	Dimensions (mm) (MAX)				Wt. (kg)
		0.3 bar	1 bar	3 bar		0.2 bar	0.3 bar	0.5 bar	0.7 bar	1 bar	1.5 bar	2 bar	3 bar			A	B	C	D	
1	THFW1508	100°	100°	100°	34.2	15.3	18.7	24.2	28.6	34.2	41.9	48.3	59.2	8.73	8.73	58.7	79.5	63.3	39.4	0.47
	THFW1808	115°	115°	115°	41.0	18.3	22.5	29.0	34.3	41.0	50.2	58.0	71.0	9.53	9.53					
	THFW2308	120°	120°	120°	52.4	23.4	28.7	37.1	43.9	52.4	64.2	74.1	90.8	11.1	11.1					
	THFW2708				61.5	27.5	33.7	43.5	51.5	61.5	75.4	87.0	107	13.9	13.9					
	THFW3208				72.9	32.6	39.9	51.6	61.0	72.9	89.3	103	126	15.2	15.2					
THFW3808	86.6	38.7	47.4	61.2	72.5	86.6	106	122	150											
1 1/4	THFW3210	120°	120°	120°	72.9	32.6	39.9	51.6	61.0	72.9	89.3	103	126	13.9	13.9	74.2	99.3	75.4	46.7	0.75
	THFW3810				86.6	38.7	47.4	61.2	72.5	86.6	106	122	150	15.9	15.9					
	THFW4110				93.4	41.8	51.2	66.1	78.2	93.4	114	132	162	16.7	16.7					
	THFW5210				119	53.0	64.9	83.8	99.1	119	145	168	205	19.8	19.8					
	THFW7010				160	71.3	87.4	113	133	160	195	226	276	26.2	22.6					
1 1/2	THFW6112	110°	110°	110°	139	62.2	76.1	98.3	116	139	170	197	241	19.4	19.4	75.7	105	94.0	59.9	0.88
	THFW7012	112°	115°	115°	160	71.3	87.4	113	133	160	195	226	276	21.4	21.4					
	THFW7712	117°	120°	120°	175	78.5	96.1	124	147	175	215	248	304	23.4	23.4					
	THFW9012				205	91.7	112	145	172	205	251	290	355	26.2	26.2					
	THFW12712				289	129	159	205	242	289	354	409	501	32.9	27.0					
	THFW14512				330	148	181	234	276	330	405	467	572	36.1	27.0					

$$\text{Flow Rate (l/min)} = K \sqrt{\text{bar}}$$

Standard Materials: Brass, Carbon Steel, and 316 Stainless Steel

Spray angle performance varies with pressure. Contact BETE for specific data on critical applications.

TO ORDER: specify pipe size, connection type, nozzle number, spray angle, and material.



HOLLOW CONE



Silicon Carbide, Flanged

Dimensions are approximate. Check with BETE for critical dimension applications.

**THW Flow Rates and Dimensions**

Hollow Cone, Wide Spray Angles, 1" to 3" Pipe Sizes, BSP or NPT

Female Pipe Size	Nozzle Number	Spray Angles			K Factor	LITERS PER MINUTE @ BAR								Approx. Orifice Dia. (mm)	Free Pass. Dia. (mm)	Dimensions (mm) (MAX)				Wt. (kg)
		0.3 bar	1 bar	3 bar		0.2 bar	0.3 bar	0.5 bar	0.7 bar	1 bar	1.5 bar	2 bar	3 bar			A	B	C	D	
2	THFW8516	112°	115°	115°	194	86.6	106	137	162	194	237	274	336	21.8	21.8	92.2	131	117	72.6	1.47
	THFW10516	120°	120°	120°	239	107	131	169	200	239	293	338	414	25.4	25.4					
	THFW12516	119°	120°	120°	285	127	156	201	238	285	349	403	493	29.0	29.0					
	THFW14516	120°	120°	120°	330	148	181	234	276	330	405	467	572	32.1	32.1					
	THFW17016				387	173	212	274	324	387	474	548	671	35.3	35.3					
	THFW19216				438	196	240	309	366	438	536	619	758	38.5	36.5					
	THFW20516				467	209	256	330	391	467	572	661	809	41.3	36.5					
	THFW23016	524	234	287	371	439	524	642	741	908	44.5	36.5								
2 1/2	THFW17020	117°	120°	120°	387	173	212	274	324	387	474	548	671	33.7	33.7	125	180	156	104	3.20
	THFW19020				433	194	237	306	362	433	530	612	750	36.1	36.1					
	THFW20520				467	209	256	330	391	467	572	661	809	37.3	37.3					
	THFW23020				524	234	287	371	439	524	642	741	908	40.1	40.1					
	THFW28020	120°	120°	120°	638	285	349	451	534	638	781	902	1110	46.0	44.5					
	THFW32020				729	326	399	516	610	729	893	1030	1260	51.2	44.5					
	THFW34020				775	347	424	548	648	775	949	1100	1340	53.2	44.5					
	THFW43520				991	443	543	701	829	991	1210	1400	1720	61.9	44.5					
3	THFW18524	120°	120°	120°	422	189	231	298	353	422	516	596	730	32.5	32.5	149	209	182	117	4.29
	THFW23024				524	234	287	371	439	524	642	741	908	36.5	36.5					
	THFW28024				638	285	349	451	534	638	781	902	1110	41.3	41.3					
	THFW32024				729	326	399	516	610	729	893	1030	1260	45.2	45.2					
	THFW34024				775	347	424	548	648	775	949	1100	1340	46.8	46.8					
	THFW41224				939	420	514	664	786	939	1150	1330	1630	53.6	53.6					
	THFW46924				1070	478	585	756	894	1070	1310	1510	1850	57.9	54.0					
	THFW52624				1200	536	657	848	1000	1200	1470	1700	2080	63.1	54.0					
	THFW56424				1290	575	704	909	1080	1290	1570	1820	2230	65.9	54.0					

Flow Rate (l/min) = K √bar

Standard Materials: Brass, Carbon Steel, and 316 Stainless Steel

Spray angle performance varies with pressure. Contact BETE for specific data on critical applications.

Call for the name of your nearest BETE representative.  
CALL 413-772-0846

# BJ

Low Flow



FAN

## DESIGN FEATURES

- Three-piece construction
- Interchangeable spray tips
- Integral strainer available
- Male and female connections

## SPRAY CHARACTERISTICS

- Relatively coarse atomization
- Uniform distribution with tapered edges for use in overlapping sprays

**Spray pattern:** Flat Fan

**Spray angles:** 0° to 110°

**Flow rate:** 0.084 to 101 l/min

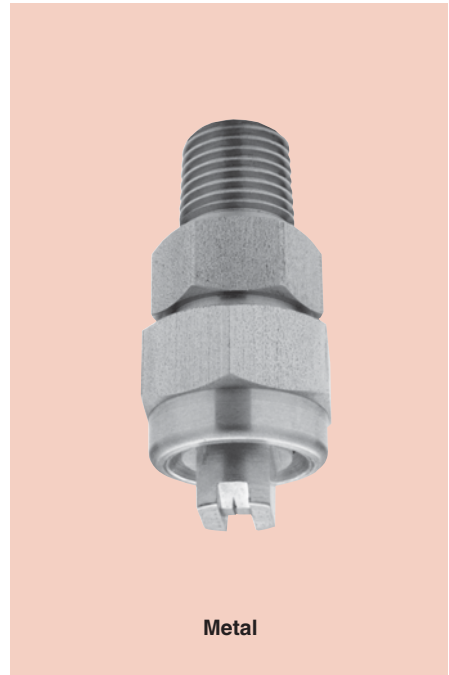

Metal

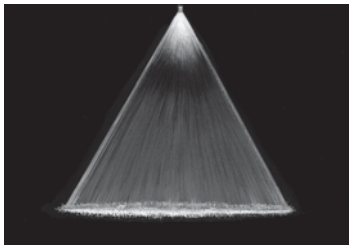

Fan 50°

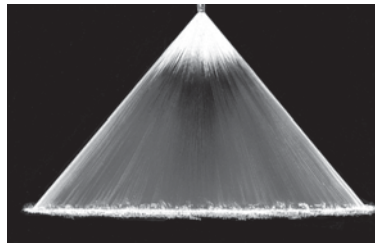

Fan 80°

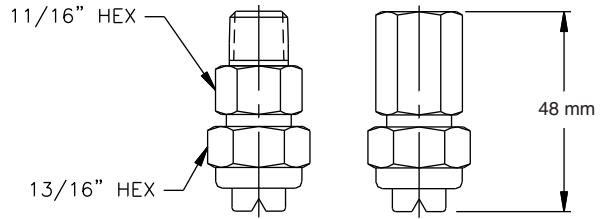

Dimensions are approximate. Check with BETE for critical dimension applications.

### BJ Dimensions

Fan, 0° to 110° Spray Angles, 1/8", 1/4", 3/8 and 1/2" Pipe Size, Male and Female

Pipe Size	Nozzle Number	Flow Rate @ 3 bar	Available Spray Angle											Optional Strainer Mesh Size	Wt. (g)	
			0°	15°	25°	40°	50°	65°	73°	80°	95°	110°				
1/8"	BJ 0067	0.26	0°	15°	25°	40°	50°	65°							100	28
	BJ 0077	0.3							73°							
	BJ 01	0.39	0°	15°	25°	40°	50°	65°		80°	95°	110°				
	BJ 0116	0.46							73°							
OR	BJ 015	0.59	0°	15°	25°	40°	50°	65°		80°	95°	110°		50	28	
	BJ 0154	0.61							73°							
	BJ 02	0.79	0°	15°	25°	40°	50°	65°		80°	95°	110°				
	BJ 0231	0.91							73°							
1/4"	BJ 03	1.81	0°	15°	25°	40°	50°	65°		80°	95°	110°		50	28	
	BJ 0308	1.22							73°							
	BJ 0385	1.52	0°	15°	25°	40°	50°	65°		80°	95°	110°				
	BJ 04	1.58							73°							
OR	BJ 0462	1.82							73°					50	28	
	BJ 05	1.97	0°	15°	25°	40°	50°	65°		80°	95°	110°				
	BJ 06	2.37	0°	15°	25°	40°	50°	65°		80°	95°	110°				
	BJ 0616	2.43							73°							
3/8"	BJ 077	3.04							73°				50	28		
	BJ 08	3.16	0°	15°	25°	40°	50°	65°		80°	95°	110°				
	BJ 0924	3.65							73°							
	BJ 10	3.95	0°	15°	25°	40°	50°	65°		80°	95°	110°				
OR	BJ 15	5.92	0°	15°	25°	40°	50°	65°		80°	95°	110°		50	28	
	BJ 20	7.89	0°	15°	25°	40°	50°	65°		80°	95°	110°				
	BJ 30	11.8	0°	15°	25°	40°	50°	65°		80°	95°	110°				
	BJ 40	15.8	0°	15°	25°	40°	50°	65°		80°	95°	110°				
1/2"	BJ 50	19.7		15°	25°	40°	50°	65°		80°	95°	110°	50	28		
	BJ 60	23.7		15°	25°	40°	50°	65°		80°	95°	110°				
	BJ 70	27.6		15°	25°	40°	50°	65°		80°	95°	110°				

Spray angle performance varies with pressure. Contact BETE for specific data on critical applications.

TO ORDER: specify pipe size, connection type, nozzle number, spray angle, and material.

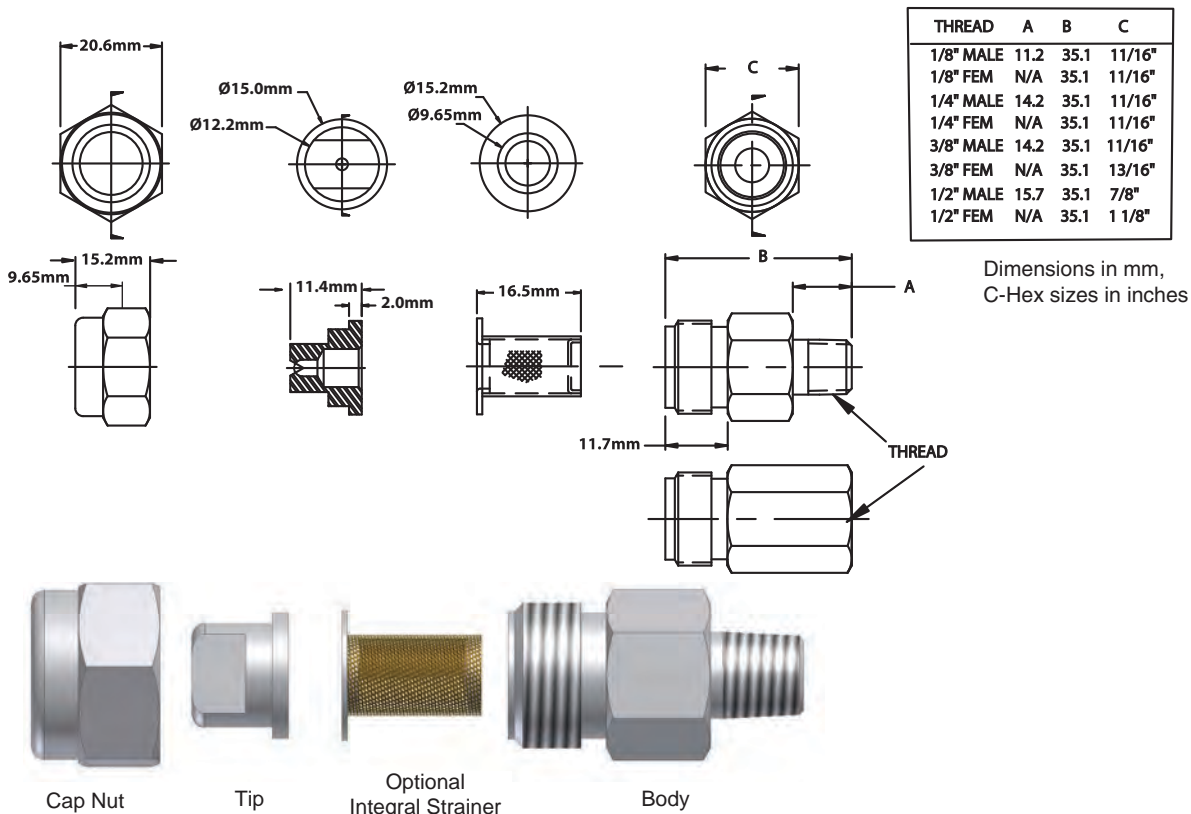

Dimensions are approximate. Check with BETE for critical dimension applications.

### BJ Flow Rates

Fan, 0°, 15°, 25°, 40°, 50°, 65°, 73°, 80°, 95°, 110° Spray Angles, 1/8", 1/4" and 3/8" Pipe Size, Male and Female

Pipe Size	Nozzle Number	Equiv. Orifice Dia. (mm)	K Factor	LITERS PER MINUTE @ BAR									
				0.3 bar	0.5 bar	0.7 bar	2 bar	4 bar	5 bar	10 bar	20 bar	30 bar	40 bar
1/8"	BJ 0067	0.58	0.153	0.084	0.11	0.13	0.22	0.31	0.34	0.48	0.68	0.84	0.97
	BJ 0077	0.58	0.175	0.096	0.12	0.15	0.25	0.35	0.39	0.55	0.78	0.96	1.11
	BJ 01	0.71	0.228	0.12	0.16	0.19	0.32	0.46	0.51	0.72	1.02	1.25	1.44
OR	BJ 0116	0.91	0.264	0.14	0.19	0.22	0.37	0.53	0.59	0.84	1.18	1.45	1.67
	BJ 015	0.97	0.342	0.19	0.24	0.29	0.48	0.68	0.76	1.08	1.53	1.87	2.16
1/4"	BJ 0154	0.84	0.351	0.19	0.25	0.29	0.50	0.70	0.78	1.11	1.57	1.92	2.22
	BJ 02	0.99	0.456	0.25	0.32	0.38	0.64	0.91	1.02	1.44	2.04	2.50	2.88
OR	BJ 0231	1.02	0.526	0.29	0.37	0.44	0.74	1.05	1.18	1.66	2.35	2.88	3.33
	BJ 03	1.19	0.684	0.37	0.48	0.57	0.97	1.37	1.53	2.16	3.06	3.74	4.32
	BJ 0308	1.19	0.702	0.38	0.50	0.59	0.99	1.40	1.57	2.22	3.14	3.84	4.44
3/8"	BJ 0385	1.30	0.877	0.48	0.62	0.73	1.24	1.75	1.96	2.77	3.92	4.81	5.55
	BJ 04	1.40	0.912	0.50	0.64	0.76	1.29	1.82	2.04	2.88	4.08	4.99	5.77
OR	BJ 0462	1.42	1.053	0.58	0.74	0.88	1.49	2.11	2.35	3.33	4.71	5.77	6.66
	BJ 05	1.55	1.139	0.62	0.81	0.95	1.61	2.28	2.55	3.60	5.10	6.24	7.21
	BJ 06	1.70	1.367	0.75	0.97	1.14	1.93	2.73	3.06	4.32	6.11	7.49	8.65
1/2"	BJ 0616	1.70	1.404	0.77	0.99	1.17	1.99	2.81	3.14	4.44	6.28	7.69	8.88
	BJ 077	1.83	1.755	0.96	1.24	1.47	2.48	3.51	3.92	5.55	7.85	9.61	11.1
	BJ 08	1.88	1.823	1.00	1.29	1.53	2.58	3.65	4.08	5.77	8.15	9.99	11.5
	BJ 0924	1.98	2.106	1.15	1.49	1.76	2.98	4.21	4.71	6.66	9.42	11.5	13.3
	BJ 10	2.18	2.279	1.25	1.61	1.91	3.22	4.56	5.10	7.21	10.2	12.5	14.4
	BJ 15	2.72	3.418	1.87	2.42	2.86	4.83	6.84	7.64	10.8	15.3	18.7	21.6
	BJ 20	3.18	4.558	2.50	3.22	3.81	6.45	9.12	10.2	14.4	20.4	25.0	28.8
BJ 30	3.67	6.837	3.74	4.83	5.72	9.67	13.7	15.3	21.6	30.6	37.4	43.2	
3/8"	BJ 40	3.97	9.116	4.99	6.45	7.63	12.9	18.2	20.4	28.8	40.8	49.9	57.7
	BJ 50	4.37	11.394	6.24	8.06	9.53	16.1	22.8	25.5	36.0	51.0	62.4	72.1
1/2"	BJ 60	4.76	13.673	7.49	9.67	11.4	19.3	27.3	30.6	43.2	61.1	74.9	86.5
	BJ 70	5.16	15.952	8.74	11.3	13.3	22.6	31.9	35.7	50.4	71.3	87.4	101--

$$\text{Flow Rate (l/min)} = K \sqrt{-\text{bar}}$$

Standard Materials: Brass, 303 Stainless Steel, and 316 Stainless Steel (for nozzle number BJ01 and higher).

Spray angle performance varies with pressure. Contact BETE for specific data on critical applications.



Call for the name of your nearest BETE representative.  
CALL 413-772-0846



# BJH

## Low Flow



Metal

### DESIGN FEATURES

- Interchangeable spray tips
- Integral strainer available
- Male and female connections
- Tips can be used with BETE HydroPulse and BJ assemblies
- Tungsten carbide orifice inserts for maximum wear resistance and service life
- Male and Female Pipe Sizes: 1/8", 1/4", 3/8", and 1/2"

### SPRAY CHARACTERISTICS

- Relatively coarse atomization
- Uniform distribution with tapered edges for use in overlapping sprays

Spray pattern: Flat Fan

Spray angles: 5° to 120°

Flow rate: 0.048 to 16.6 L/min

FAN

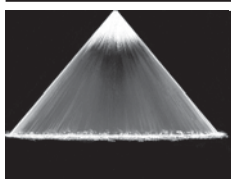

Fan 80°

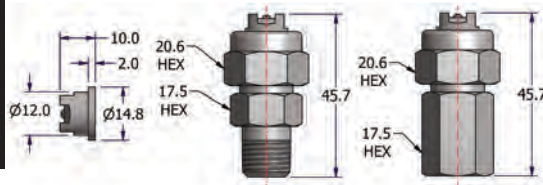

### To Order: Spray Set-up Number

1/4 BJH 0.18 25 -S -B 316

pipe size | series | specify assembly material  
nozzle number | if BSP (R/Rp) thread  
spray angle | optional strainer, see below for size

### BJH Flow Rates, Spray Angles, and Dimensions

Fan, 5° to 120° Spray Angles, 1/8", 1/4", 3/8", and 1/2" Pipe Size, Male and Female

Nozzle Number	K Factor	LITERS PER MINUTE @ BAR							Equivalent Orifice Dia. (mm)	Available Spray Angles	Optional Strainer Mesh Size	Wt. (g)
		2 bar	3 bar	4 bar	7 bar	30 bar	50 bar	70 bar				
BJH-0.18	0.018	-	-	-	0.048	0.099	0.127	0.151	0.18	5°, 10°, 15°, 20°, 25°, 30°, 33°, 40°, 50°	400	28
BJH-0.23	0.029	-	-	-	0.077	0.159	0.205	0.243	0.23	5°, 10°, 15°, 20°, 25°, 30°, 33°, 40°, 50°, 65°	400	28
BJH-0.28	0.043	-	-	-	0.114	0.236	0.304	0.360	0.28	5°, 10°, 20°, 33°, 40°, 50°, 65°, 73°	400	28
BJH-0.33	0.059	-	-	-	0.156	0.323	0.417	0.494	0.33	5°, 10°, 20°, 33°, 40°, 50°, 65°, 73°, 80°, 90°	400	28
BJH-0.38	0.079	-	-	-	0.209	0.433	0.559	0.661	0.38	10°, 20°, 33°, 40°, 50°, 65°, 73°, 80°, 90°, 100°	400	28
BJH-0.43	0.100	-	-	-	0.265	0.548	0.707	0.837	0.43			
BJH-0.45	0.110	0.156	0.191	0.220	0.291	0.602	0.778	0.920	0.45			
BJH-0.48	0.125	0.177	0.217	0.250	0.331	0.685	0.884	1.05	0.48	10°, 20°, 33°, 40°, 50°, 65°, 73°, 80°, 90°, 100°, 110°, 120°	400	28
BJH-0.53	0.152	0.215	0.263	0.304	0.402	0.833	1.07	1.27	0.53			
BJH-0.58	0.183	0.259	0.317	0.366	0.484	1.00	1.29	1.53	0.58			
BJH-0.63	0.216	0.305	0.374	0.432	0.571	1.18	1.53	1.81	0.63			
BJH-0.66	0.237	0.335	0.410	0.474	0.627	1.30	1.68	1.98	0.66			
BJH-0.68	0.251	0.355	0.435	0.502	0.664	1.37	1.77	2.10	0.68			
BJH-0.73	0.289	0.409	0.501	0.578	0.765	1.58	2.04	2.42	0.73			
BJH-0.78	0.330	0.467	0.572	0.660	0.873	1.81	2.33	2.76	0.78	10°, 20°, 33°, 40°, 50°, 65°, 73°, 80°, 90°, 100°, 110°, 120°	200	28
BJH-0.84	0.383	0.542	0.663	0.766	1.01	2.10	2.71	3.20	0.84			
BJH-0.89	0.430	0.608	0.745	0.860	1.14	2.36	3.04	3.60	0.89			
BJH-0.94	0.480	0.679	0.831	0.960	1.27	2.63	3.39	4.02	0.94			
BJH-0.99	0.532	0.752	0.921	1.06	1.41	2.91	3.76	4.45	0.99			
BJH-1.04	0.587	0.830	1.02	1.17	1.55	3.22	4.15	4.91	1.04			
BJH-1.09	0.645	0.912	1.12	1.29	1.71	3.53	4.56	5.40	1.09			
BJH-1.14	0.706	0.998	1.22	1.41	1.87	3.87	4.99	5.91	1.14	20°, 33°, 40°, 50°, 65°, 73°, 80°, 90°, 100°, 110°, 120°	100	28
BJH-1.19	0.769	1.09	1.33	1.54	2.03	4.21	5.44	6.43	1.19			
BJH-1.24	0.835	1.18	1.45	1.67	2.21	4.57	5.90	6.99	1.24			
BJH-1.29	0.904	1.28	1.57	1.81	2.39	4.95	6.39	7.56	1.29			
BJH-1.32	0.945	1.34	1.64	1.89	2.50	5.18	6.68	7.91	1.32			
BJH-1.35	0.990	1.40	1.71	1.98	2.62	5.42	7.00	8.28	1.35	20°, 33°, 40°, 50°, 65°, 73°, 80°, 90°, 100°, 110°	100	28
BJH-1.40	1.06	1.50	1.84	2.12	2.80	5.81	7.50	8.87	1.40			
BJH-1.45	1.14	1.61	1.97	2.28	3.02	6.24	8.06	9.54	1.45			
BJH-1.50	1.22	1.73	2.11	2.44	3.23	6.68	8.63	10.2	1.50			
BJH-1.55	1.31	1.85	2.27	2.62	3.47	7.18	9.26	11.0	1.55			
BJH-1.57	1.34	1.90	2.32	2.68	3.55	7.34	9.48	11.2	1.57	20°, 33°, 40°, 50°, 65°, 73°, 80°, 90°, 100°	100	28
BJH-1.60	1.39	1.97	2.41	2.78	3.68	7.61	9.83	11.6	1.60			
BJH-1.65	1.48	2.09	2.56	2.96	3.92	8.11	10.5	12.4	1.65			
BJH-1.70	1.57	2.22	2.72	3.14	4.15	8.60	11.1	13.1	1.70			
BJH-1.75	1.66	2.35	2.88	3.32	4.39	9.09	11.7	13.9	1.75			
BJH-1.80	1.76	2.49	3.05	3.52	4.66	9.64	12.4	14.7	1.80	20°, 33°, 40°, 50°, 65°, 73°, 80°, 90°	100	28
BJH-1.83	1.82	2.57	3.15	3.64	4.82	9.97	12.9	15.2	1.83			
BJH-1.85	1.86	2.63	3.22	3.72	4.92	10.2	13.2	15.6	1.85			
BJH-1.91	1.98	2.80	3.43	3.96	5.24	10.8	14.0	16.6	1.91	20°, 33°, 40°, 50°, 65°, 73°, 80°	100	28

$$\text{Flow Rate (l/min)} = K \sqrt{\text{bar}}$$

Spray angle performance varies with pressure.  
Contact BETE for specific data on critical applications.

### Standard Materials:

Body and Cap Nut: Brass, 303 Stainless Steel, and 316 Stainless Steel  
Tip: Tungsten Carbide Insert with 303 Stainless Steel Housing

www.BETE.com

TO ORDER: specify pipe size, connection type, nozzle number, spray angle, and material.

# NFH

## Low Flow

### DESIGN FEATURES

- Tungsten carbide orifice inserts for maximum wear resistance and service life
- Male connections: 1/4" NPT, BSP (R)

### SPRAY CHARACTERISTICS

- Relatively coarse atomization
- Uniform distribution with tapered edges for use in overlapping sprays

**Spray pattern:** Flat Fan

**Spray angles:** 5° to 120°

**Flow rate:** 0.048 to 16.6 L/min

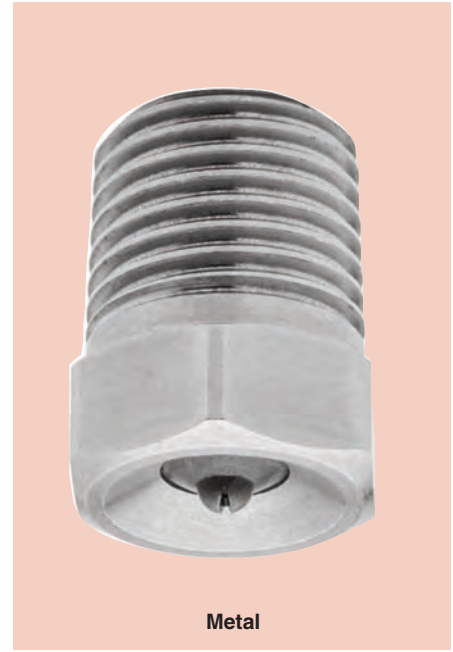

Metal



FAN

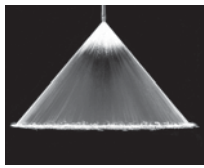

Fan 80°

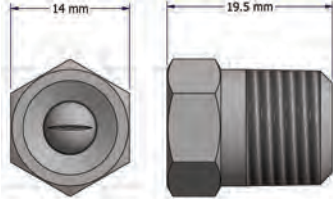

### To Order: Spray Set-up Number

1/4 NFH 0.18 25 -B

pipe size | series | nozzle number | spray angle | if BSP (R) thread

### NFH Flow Rates, Spray Angles and Dimensions Fan, 5° to 120° Spray Angles, 1/4" Pipe Size

Male Pipe Size	Nozzle Number	K Factor	LITERS PER MINUTE @ BAR							Equivalent Orifice Dia.(mm)	Available Spray Angles	Wt. (g)
			2 bar	3 bar	4 bar	7 bar	30 bar	50 bar	70 bar			
1/4"	NFH-0.18	0.018	-	-	-	0.048	0.099	0.127	0.151	0.18	5°, 10°, 15°, 20°, 25°, 30°, 33°, 40°, 50°	42.5
	NFH-0.23	0.029	-	-	-	0.077	0.159	0.205	0.243	0.23	5°, 10°, 15°, 20°, 25°, 30°, 33°, 40°, 50°, 65°	
	NFH-0.28	0.043	-	-	-	0.114	0.236	0.304	0.360	0.28	5°, 10°, 20°, 33°, 40°, 50°, 65°, 73°	
	NFH-0.33	0.059	-	-	-	0.156	0.323	0.417	0.494	0.33	5°, 10°, 20°, 33°, 40°, 50°, 65°, 73°, 80°, 90°	
	NFH-0.38	0.079	-	-	-	0.209	0.433	0.559	0.661	0.38	10°, 20°, 33°, 40°, 50°, 65°, 73°, 80°, 90°, 100°	
	NFH-0.43	0.100	-	-	-	0.265	0.548	0.707	0.837	0.43	10°, 20°, 33°, 40°, 50°, 65°, 73°, 80°, 90°, 100°, 110°, 120°	
	NFH-0.45	0.110	0.156	0.191	0.220	0.291	0.602	0.778	0.920	0.45		
	NFH-0.48	0.125	0.177	0.217	0.250	0.331	0.685	0.884	1.05	0.48		
	NFH-0.53	0.152	0.215	0.263	0.304	0.402	0.833	1.07	1.27	0.53		
	NFH-0.58	0.183	0.259	0.317	0.366	0.484	1.00	1.29	1.53	0.58		
	NFH-0.63	0.216	0.305	0.374	0.432	0.571	1.18	1.53	1.81	0.63		
	NFH-0.66	0.237	0.335	0.410	0.474	0.627	1.30	1.68	1.98	0.66	10°, 20°, 33°, 40°, 50°, 65°, 73°, 80°, 90°, 100°, 110°, 120°	
	NFH-0.68	0.251	0.355	0.435	0.502	0.664	1.37	1.77	2.10	0.68		
	NFH-0.73	0.289	0.409	0.501	0.578	0.765	1.58	2.04	2.42	0.73		
	NFH-0.78	0.330	0.467	0.572	0.660	0.873	1.81	2.33	2.76	0.78		
	NFH-0.84	0.383	0.542	0.663	0.766	1.01	2.10	2.71	3.20	0.84		
	NFH-0.89	0.430	0.608	0.745	0.860	1.14	2.36	3.04	3.60	0.89		
	NFH-0.94	0.480	0.679	0.831	0.960	1.27	2.63	3.39	4.02	0.94	20°, 33°, 40°, 50°, 65°, 73°, 80°, 90°, 100°, 110°, 120°	
	NFH-0.99	0.532	0.752	0.921	1.06	1.41	2.91	3.76	4.45	0.99		
	NFH-1.04	0.587	0.830	1.02	1.17	1.55	3.22	4.15	4.91	1.04		
	NFH-1.09	0.645	0.912	1.12	1.29	1.71	3.53	4.56	5.40	1.09		
	NFH-1.14	0.706	0.998	1.22	1.41	1.87	3.87	4.99	5.91	1.14		
	NFH-1.19	0.769	1.09	1.33	1.54	2.03	4.21	5.44	6.43	1.19		
	NFH-1.24	0.835	1.18	1.45	1.67	2.21	4.57	5.90	6.99	1.24	20°, 33°, 40°, 50°, 65°, 73°, 80°, 90°, 100°, 110°	
NFH-1.29	0.904	1.28	1.57	1.81	2.39	4.95	6.39	7.56	1.29			
NFH-1.32	0.945	1.34	1.64	1.89	2.50	5.18	6.68	7.91	1.32			
NFH-1.35	0.990	1.40	1.71	1.98	2.62	5.42	7.00	8.28	1.35			
NFH-1.40	1.06	1.50	1.84	2.12	2.80	5.81	7.50	8.87	1.40			
NFH-1.45	1.14	1.61	1.97	2.28	3.02	6.24	8.06	9.54	1.45			
NFH-1.50	1.22	1.73	2.11	2.44	3.23	6.68	8.63	10.2	1.50	20°, 33°, 40°, 50°, 65°, 73°, 80°, 90°, 100°		
NFH-1.55	1.31	1.85	2.27	2.62	3.47	7.18	9.26	11.0	1.55			
NFH-1.57	1.34	1.90	2.32	2.68	3.55	7.34	9.48	11.2	1.57			
NFH-1.60	1.39	1.97	2.41	2.78	3.68	7.61	9.83	11.6	1.60			
NFH-1.65	1.48	2.09	2.56	2.96	3.92	8.11	10.5	12.4	1.65			
NFH-1.70	1.57	2.22	2.72	3.14	4.15	8.60	11.1	13.1	1.70			
NFH-1.75	1.66	2.35	2.88	3.32	4.39	9.09	11.7	13.9	1.75	20°, 33°, 40°, 50°, 65°, 73°, 80°, 90°		
NFH-1.80	1.76	2.49	3.05	3.52	4.66	9.64	12.4	14.7	1.80			
NFH-1.83	1.82	2.57	3.15	3.64	4.82	9.97	12.9	15.2	1.83			
NFH-1.85	1.86	2.63	3.22	3.72	4.92	10.2	13.2	15.6	1.85			
NFH-1.91	1.98	2.80	3.43	3.96	5.24	10.8	14.0	16.6	1.91			
NFH-1.91	1.98	2.80	3.43	3.96	5.24	10.8	14.0	16.6	1.91		20°, 33°, 40°, 50°, 65°, 73°, 80°	

Flow Rate (l/min) = K √bar

Spray angle performance varies with pressure.  
Contact BETE for specific data on critical applications.

### Standard Materials:

Tungsten Carbide Insert, 303 Stainless Steel Housing

# NFV

## Fan Nozzle with Integral Strainer Option

### DESIGN FEATURES

- One-piece construction
- No internal parts
- Male connection
- Low nozzle maintenance
- Optional removable strainer for easy cleaning

**Connections:** Male NPT and BSP

**Optional Strainer:** 50, 100, 200 mesh

### SPRAY CHARACTERISTICS

- High impact
- Uniform distribution

**Spray pattern:** Flat Fan and Straight Jet

**Spray angles:** 0°, 15°, 25°, 40°, 50°, 65°, 80°, 95°, and 110°

**Flow rates:** 0.15 to 49.85 l/min

NFV0067: Max. spray angle available 95°



**Metal**  
Shown with Optional Strainer

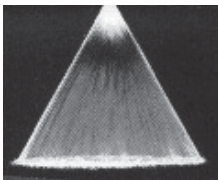

Fan 50°

Call BETE to verify spray angle performance at operating pressures above 30 bar.

### NFV Dimensions

Pipe Size	Dimensions (mm)			Wt. (g)
	A	B	C	
1/8	22.4	11.2	37.9	28.4
1/4	26.9	14.2	42.9	42.5

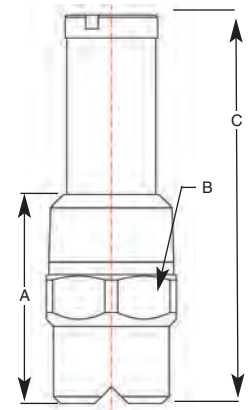

1/8" - 1/4" Metal

### To Order: Spray Set-up Number

1/4 NFV 0067 95 -L -B 303

pipe size | series | nozzle number | spray angle | BSP thread | optional strainer, also specify mesh size | specify material

### NFV Flow Rates

Fan and Straight Jet, 0°, 15°, 25°, 40°, 50°, 65°, 80°, 95° (all sizes); 110° (NFV01 and higher)

Male Pipe Size	Nozzle Number	K Factor	LITERS PER MINUTE @ BAR						Equiv. Orifice Dia. (mm)	Screen Mesh Selection Guide
			1 bar	2 bar	3 bar	5 bar	10 bar	30 bar		
1/8" or 1/4"	NFV0067**	0.153	0.15	0.22	0.26	0.34	0.48	0.84	0.58	100
	NFV01	0.228	0.23	0.32	0.39	0.51	0.72	1.25	0.66	100
	NFV015	0.342	0.34	0.48	0.59	0.76	1.08	1.87	0.79	100
	NFV02	0.456	0.46	0.64	0.79	1.02	1.44	2.50	0.91	100
	NFV025	0.569	0.57	0.80	0.99	1.27	1.80	3.12	1.02	50
	NFV03	0.684	0.68	0.97	1.18	1.53	2.16	3.75	1.09	50
	NFV04	0.912	0.91	1.29	1.58	2.04	2.88	5.00	1.32	50
	NFV05	1.139	1.14	1.61	1.97	2.55	3.60	6.24	1.45	50
	NFV06	1.367	1.37	1.93	2.37	3.06	4.32	7.48	1.57	50
	NFV07	1.598	1.60	2.26	2.77	3.57	5.05	8.75	2.08	50
	NFV08	1.823	1.82	2.58	3.16	4.08	5.76	9.98	1.83	50
	NFV10	2.279	2.28	3.22	3.95	5.10	7.21	12.48	2.03	50
	NFV15	3.418	3.42	4.83	5.92	7.64	10.81	18.72	2.39	50
	NFV20	4.550	4.55	6.44	7.88	10.18	14.39	24.92	2.77	50
	NFV30	6.826	6.83	9.65	11.82	15.26	21.58	37.39	3.58	50
	NFV40	9.101	9.10	12.87	15.76	20.35	28.78	49.85	3.96	50

\*\*NFV0067: Max. spray angle available: 95°

Flow Rate (L/min) =  $K \sqrt{\text{bar}}$  Standard Materials: Brass and 303 Stainless Steel. Highlighted NFVs available in 316 Stainless Steel.

Spray angle performance varies with pressure. Contact BETE for specific data on critical applications.

TO ORDER: specify pipe size, connection type, nozzle number, spray angle, and material.

# NF

## Standard Fan Nozzle

### DESIGN FEATURES

- One-piece construction
- No internal parts
- Sizes for all applications
- Male connection

### SPRAY CHARACTERISTICS

- High impact
  - Uniform distribution with tapered edges for overlapping sprays
  - Extra-wide angles available
- Spray pattern:** Fan and Straight Jet  
**Spray angles:** 0° to 120°  
**Flow rates:** 0.161 to 3430 l/min

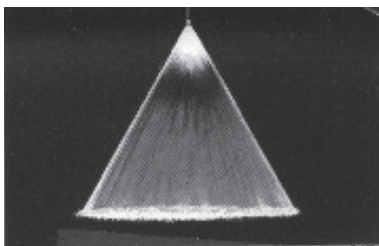
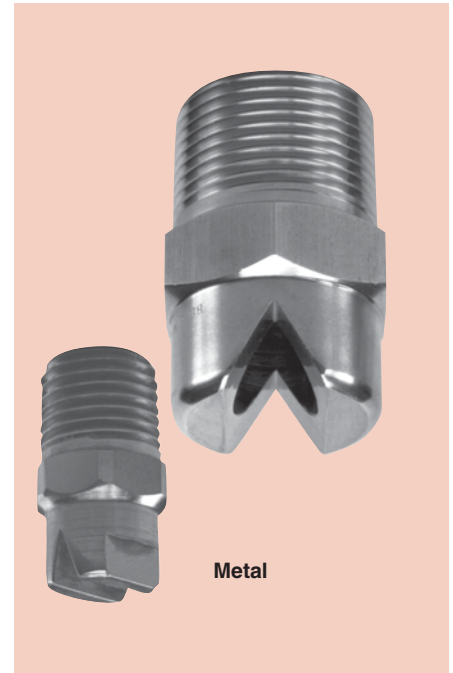

Fan 50°

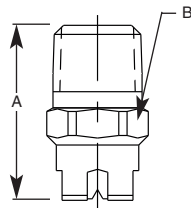

3/8" - 2" Metal

Call BETE to verify spray angle performance at operating pressures above 5 bar.

Dimensions are approximate. Check with BETE for critical dimension applications.

### NF Flow Rates

Call BETE to verify spray angle performance at operating pressures above 5 bar.

Fan and Straight Jet, 0°, 15°, 30°, 50°, 65°, 80°, 90°, 110°, and 120° Spray Angles, 1/8" to 2" Pipe Sizes

### NF Dimensions

BSP or NPT

Male Pipe Size	Nozzle Number	K Factor	LITERS PER MINUTE @ BAR								Equivalent Orifice Dia. (mm)	Dim. for Metal Only (mm)		Wt. (g)		
			0.5 bar	0.7 bar	1 bar	2 bar	3 bar	5 bar	10 bar	30 bar		Pipe Size	A	B	Metal	Plas.
1/8 or 1/4	NF01	0.228	0.16	0.19	0.23	0.32	0.39	0.51	0.72	1.25	0.66	1/8	22.2	11.1	28.4	7.09
	NF015	0.342	0.24	0.29	0.34	0.48	0.59	0.76	1.08	1.87	0.79					
	NF02	0.455	0.32	0.38	0.46	0.64	0.79	1.02	1.44	2.49	0.91					
	NF025	0.569	0.40	0.48	0.57	0.81	0.99	1.27	1.80	3.12	1.02					
	NF03	0.683	0.48	0.57	0.68	0.97	1.18	1.53	2.16	3.74	1.09					
	NF04	0.911	0.64	0.76	0.91	1.29	1.58	2.04	2.88	4.99	1.32					
	NF05	1.14	0.81	0.95	1.14	1.61	1.97	2.55	3.60	6.24	1.45					
	NF06	1.37	0.97	1.14	1.37	1.93	2.37	3.06	4.33	7.49	1.57					
NF08	1.82	1.28	1.52	1.82	2.57	3.15	4.06	5.74	9.95	1.83	1/4	27.0	14.3	42.5	10.6	
1/8	NF10	2.28	1.61	1.91	2.28	3.22	3.95	5.10	7.21	12.5						2.03
or	NF15	3.42	2.42	2.86	3.42	4.83	5.92	7.64	10.8	18.7						2.38
1/4	NF20	4.56	3.22	3.81	4.56	6.45	7.89	10.2	14.4	25.0						2.78
or	NF30	6.84	4.83	5.72	6.84	9.67	11.8	15.3	21.6	37.4						3.57
3/8	NF40	9.12	6.45	7.63	9.12	12.9	15.8	20.4	28.8	49.9						3.97
1/4	NF50	11.4	8.06	9.53	11.4	16.1	19.7	25.5	36.0	62.4						4.37
or	NF60	13.7	9.67	11.4	13.7	19.3	23.7	30.6	43.2	74.9						4.76
3/8	NF70	16.0	11.3	13.3	16.0	22.6	27.6	35.7	50.4	87.4	5.16	1/2	38.1	22.2	85.1	28.4
3/8	NF60	13.7	9.67	11.4	13.7	19.3	23.7	30.6	43.2	74.9	4.76					
or	NF70	16.0	11.3	13.3	16.0	22.6	27.6	35.7	50.4	87.4	5.16					
1/2	NF80	18.2	12.9	15.3	18.2	25.8	31.6	40.8	57.7	99.9	5.56					
or	NF90	20.5	14.5	17.2	20.5	29.0	35.5	45.9	64.9	112	5.95					
1/2	NF100	22.8	16.1	19.1	22.8	32.2	39.5	51.0	72.1	125	6.35					
or	NF120	27.3	19.3	22.9	27.3	38.7	47.4	61.1	86.5	150	6.75					
1/2	NF150	34.2	24.2	28.6	34.2	48.3	59.2	76.4	108	187	7.54					
or	NF200	45.6	32.2	38.1	45.6	64.5	78.9	102	144	250	8.73	3/4	44.5	28.6	170	42.5
3/4	NF300	68.4	48.3	57.2	68.4	96.7	118	153	216	374	10.7					
or	NF400	91.2	64.5	76.3	91.2	129	158	204	288	499	12.7					
1	NF400	91.2	64.5	76.3	91.2	129	158	204	288	499	12.7					
or	NF750	171	121	143	171	242	296	382	540	936	17.5					
1 1/4	NF800	182	129	153	182	258	316	408	577	999	18.3					
or	NF1150	262	185	219	262	371	454	586	829	1440	21.8					
1 1/2	NF1500	342	242	286	342	483	592	764	1080	1870	24.6					
2	NF2250	513	362	429	513	725	890	1150	1620	2810	30.2					

Flow Rate (l/min) =  $K \sqrt{\text{bar}}$  Standard Materials: Brass, 303 Stainless Steel, 316 Stainless Steel, PVC, and PTFE (PTFE not available in nozzle numbers NF025 and under)

Spray angle performance varies with pressure. Contact BETE for specific data on critical applications.



# NFD

## Dovetail Flat Fan

### DESIGN FEATURES

- Dovetail joint guarantees alignment of interchangeable tips
- Dimensionally compatible with other dovetail systems
- Tips offset 5° or 15° for overlapping spray patterns
- Tapered overlapping spray provides uniform coverage
- Male, female and welded connections
- Other sizes available upon request

### SPRAY CHARACTERISTICS

- **Spray pattern:** Flat Fan
- **Spray angles:** 20°, 30°, 45°, 60°, 90°, and 120°. Special angles are available on request
- **Flow rates:** 0.159 to 358 l/min

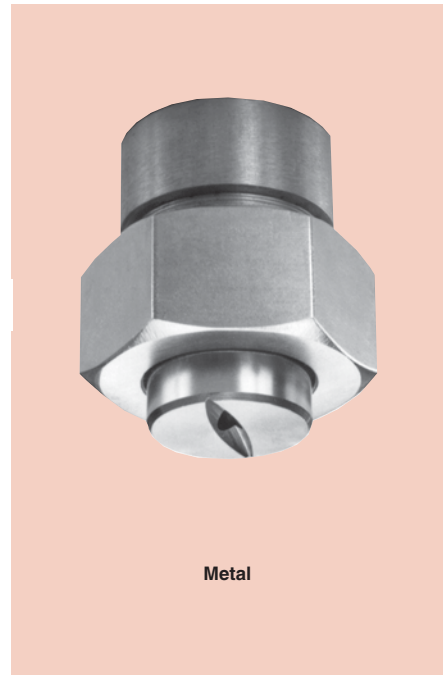

Metal

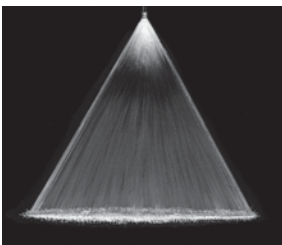

Fan 45°

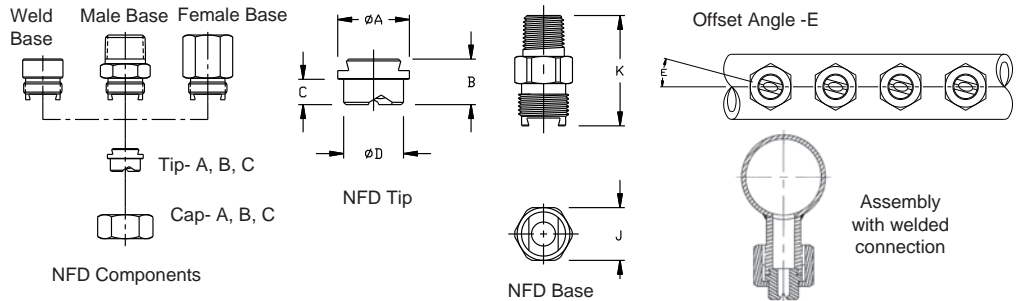

Dimensions are approximate. Check with BETE for critical dimension applications.

### NFD Flow Rates and Dimensions

Fan, 20°, 30°, 45°, 60°, 90°, 120° Spray Angles, 1/4", 3/8", 1/2", 3/4" and 1-1/4" Pipe Size, BSP or NPT, or Welded Connections

Cap & Tip Size	Nozzle Number	Base Sizes* Available	K Factor	LITERS PER MINUTE @ BAR							Equiv. Orifice Dia. (mm)	Approximate Tip Dimensions (mm)				Wt. (g)	BSP NPT Pipe	Approx. Base Dim. (mm)		
				0.5 bar	1 bar	2 bar	3 bar	5 bar	7 bar	10 bar		A	B	C	D			J	K	
A	NFD 010	1/4 3/8 1/2	0.225	0.159	0.225	0.318	0.390	0.503	0.596	0.712	0.700	14.8	12	5°	42	1/4"	17.5	36.5		
	NFD 014	1/4 3/8 1/2	0.318	0.225	0.318	0.449	0.550	0.710	0.840	1.00	0.900									
	NFD 019	1/4 3/8 1/2	0.445	0.314	0.445	0.629	0.770	0.994	1.18	1.41	1.00									
	NFD 031	1/4 3/8 1/2	0.704	0.498	0.704	0.996	1.22	1.58	1.86	2.23	1.20	7	12	5°	42	1/4"	17.5	36.5		
	NFD 039	1/4 3/8 1/2	0.883	0.625	0.883	1.25	1.53	1.98	2.34	2.79	1.35									
	NFD 050	1/4 3/8 1/2	1.13	0.800	1.13	1.60	1.96	2.53	2.99	3.58	1.50									
	NFD 059	1/4 3/8 1/2	1.34	0.947	1.34	1.89	2.32	3.00	3.54	4.24	1.65	9	12	5°	42	3/8"	17.5	36.5		
	NFD 077	1/4 3/8 1/2	1.77	1.25	1.77	2.50	3.06	3.95	4.67	5.59	2.00									
	NFD 097	1/4 3/8 1/2	2.22	1.57	2.22	3.14	3.85	4.97	5.88	7.03	2.20									
NFD 12	1/4 3/8 1/2	2.82	2.00	2.82	3.99	4.89	6.31	7.47	8.93	2.50	20	12	5°	42	3/8"	17.5	36.5			
NFD 15	1/4 3/8 1/2	3.35	2.37	3.35	4.74	5.81	7.50	8.87	10.6	2.70										
NFD 20	3/4	4.45	3.15	4.45	6.30	7.71	10.0	11.8	14.1	3.00										
B	NFD 25	3/4	5.65	4.00	5.65	7.99	9.79	12.6	15.0	17.9	3.50	24	15	15°	168	1/2"	22	44.5		
	NFD 31	3/4	7.04	4.98	7.04	9.96	12.2	15.8	18.6	22.3	4.00									
	NFD 39	3/4	8.83	6.25	8.83	12.5	15.3	19.8	23.4	27.9	4.50									
	NFD 50	3/4	11.3	8.00	11.3	16.0	19.6	25.3	29.9	35.8	5.00	9	12	15°	168	3/4"	28.5	51		
	NFD 62	3/4	14.1	10.0	14.1	20.0	24.5	31.6	37.4	44.7	5.50									
	NFD 77	3/4	17.7	12.5	17.7	25.0	30.6	39.5	46.7	55.9	6.00									
	NFD 87	3/4	19.8	14.0	19.8	28.0	34.3	44.3	52.4	62.6	6.40	20	12	15°	168	3/4"	28.5	51		
	NFD 104	3/4	23.7	16.7	23.7	33.5	41.0	52.9	62.6	74.9	7.20									
	NFD 124	3/4	28.3	20.0	28.3	40.0	49.0	63.3	74.8	89.5	8.00									
	NFD 155	3/4	35.3	25.0	35.3	50.0	61.2	79.0	93.5	112	9.00	38.5	22	13.5	32	15°	224	1-1/4"	44.5	63.5
NFD 195	3/4	44.5	31.4	44.5	62.9	77.0	99.4	118	141	10.0										
NFD 124	1-1/4	28.3	20.0	28.3	40.0	49.0	63.2	74.8	89.5	8.00										
C	NFD 195	1-1/4	44.5	31.4	44.5	62.9	77.0	99.4	118	141	10.0	38.5	22	13.5	32	15°	224	1-1/4"	44.5	63.5
	NFD 309	1-1/4	70.4	49.8	70.4	100	122	158	186	223	12.0									
	NFD 496	1-1/4	113	80.0	113	160	196	253	299	358	15.0--									

Flow Rate (l/min) =  $K \sqrt{\text{bar}}$  \* NPT, BSP, male or female or weldable connections. Dimensions are for male base, female and weldable vary.

Standard Materials: Brass, 303 Stainless Steel, and 316 Stainless Steel Weldable adapters also available in mild steel.

Spray angle performance varies with pressure. Contact BETE for specific data on critical applications.

TO ORDER: specify pipe size, connection type, nozzle number, spray angle, and material.

# NFS

## Stubby Flat Fan

### DESIGN FEATURES

- Extremely short length for minimum projection and maximum clearance
- Produces a flat fan spray pattern available in a variety of spray angles
- Available in straight (parallel) threads only, NPSM and G
- Requires gasket to seal connection

### SPRAY CHARACTERISTICS

Spray pattern: Fan

Spray angles: 20°, 30°, 45°, 60°, 90° and 120° standard

Flow rates: 0.20 to 951 l/min



Metal

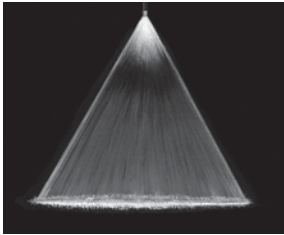

Fan 45°



Fan 90°

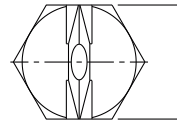
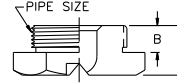

Metal

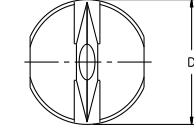
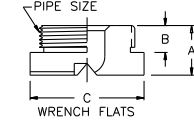

Plastic

Dimensions are approximate. Check with BETE for critical dimension applications.

### NFS Flow Rates and Dimensions

Flat Fan, 20°, 30°, 45°, 60°, 90° & 120° Spray Angles, 1/4" to 2" Pipe Sizes

** Male Pipe Size	Nozzle Number	K Factor	LITERS PER MINUTE @ BAR							Equiv. Orifice Dia. (mm)
			0.5 bar	1 bar	2 bar	3 bar	5 bar	7 bar	10 bar	
1/4"	NFS 012	0.28	0.20	0.28	0.40	0.49	0.63	0.75	0.89	0.800
	NFS 019	0.44	0.31	0.44	0.63	0.77	0.99	1.18	1.41	1.00
	NFS 031	0.71	0.50	0.71	1.00	1.23	1.59	1.88	2.25	1.20
	NFS 039	0.88	0.62	0.88	1.25	1.53	1.98	2.34	2.79	1.35
	NFS 050	1.13	0.80	1.13	1.60	1.96	2.53	2.99	3.58	1.50
	NFS 059	1.35	0.95	1.35	1.90	2.33	3.01	3.56	4.25	1.65
	NFS 077	1.77	1.25	1.77	2.50	3.06	3.95	4.67	5.59	2.00
	NFS 098	2.23	1.58	2.23	3.15	3.86	4.98	5.90	7.05	2.20
	NFS 12	2.83	2.00	2.83	4.00	4.90	6.33	7.48	8.95	2.50
	NFS 15	3.36	2.38	3.36	4.75	5.82	7.51	8.89	10.6	2.70
1/4" or 3/4"	NFS 20	4.56	3.22	4.56	6.45	7.89	10.2	12.1	14.4	3.00
	NFS 25	5.66	4.00	5.66	8.00	9.80	12.7	15.0	17.9	3.50
	NFS 31	7.10	5.02	7.10	10.0	12.3	15.9	18.8	22.5	4.00
	NFS 39	8.83	6.25	8.83	12.5	15.3	19.8	23.4	27.9	4.50
	NFS 50	11.3	8.00	11.3	16.0	19.6	25.3	29.9	35.8	5.00
	NFS 62	14.1	10.0	14.1	20.0	24.5	31.6	37.4	44.7	5.50
3/4"	NFS 77	17.7	12.5	17.7	25.0	30.6	39.5	46.7	55.9	6.00
	NFS 93	21.2	15.0	21.2	30.0	36.7	47.4	56.1	67.0	6.90
3/4" or 1-1/4"	NFS 124	28.3	20.0	28.3	40.0	49.0	63.3	74.8	89.5	8.00
	NFS 155	35.3	25.0	35.3	50.0	61.2	79.0	93.5	112	9.00
	NFS 185	42.1	29.8	42.1	59.6	73.0	94.2	112	133	9.50
1-1/4"	NFS 195	44.6	31.5	44.6	63.0	77.2	100	118	141	10.0
	NFS 309	70.4	49.8	70.4	100	122	158	186	223	12.0
2"	NFS 496	113	80.0	113	160	196	253	299	358	15.0
	NFS 557	127	89.8	127	180	220	284	336	402	16.0
	NFS 620	141	100	141	200	245	316	374	447	17.0
	NFS 775	177	125	177	250	306	395	467	559	19.0
	NFS 977	223	158	223	315	386	498	590	705	21.0
	NFS 1130	258	182	258	365	447	577	683	816	22.5
	NFS 1320	301	213	301	425	521	673	796	951	24.5

### NFS Dimensions and Spray Angles

Pipe Size	Nozzle Number	Spray Angles Available	Dimensions (mm)			
			A	B	C	D
1/4"	NFS 012 To NFS 39	20° 30° 45° 60° 90° 120°	11.9			
	NFS 50	20° 30° 45° 60° 90°	17.5			
	NFS 62	45° 60° 90°	19.1			
	NFS 77	45°	19.1			
	NFS 20 To NFS 77	20° 30° 45° 60° 90° 120°	15.0			
	NFS 93*	120°	7.87			
3/4"	NFS 124	20° 30° 45° 60° 90° 120°	31.8			
	NFS 155	20° 30° 45° 60° 90° 120°	31.8			
	NFS 185	120°	31.8			
	NFS 195	20° 30° 45° 60° 90° 120°	35.1			
	NFS 309	20° 30° 45° 60° 90° 120°	35.1			
1 1/4"	NFS 124 To NFS 496	20° 30° 45° 60° 90° 120°	22.1	11.9	50.8	
	NFS 496	60° 90° 120°	55.4			
2"	NFS 557 To NFS 1320	20° 30° 45° 60° 90° 120°	31.8	20.1	69.9	
	NFS 1320	60° 90° 120°	76.2			

Flow Rate (l/min) = K √ bar

\*\*Available in straight (parallel) threads only, NPSM and G

Standard Materials: Brass, 316 Stainless Steel, 303 Stainless Steel, and PVC

Spray angle performance varies with pressure. Contact BETE for specific data on critical applications.

# FF

## Extra-Wide Angle

### DESIGN FEATURES

- One-piece construction
- Clog resistant
- Durable
- All 3/8" FFs in Brass are available with UL approval
- Male connection
- For FM-approved flat fan nozzles, see the AFF series on page 113

### SPRAY CHARACTERISTICS

- Extra-wide 145° spray angle
  - Medium-impact spray
  - Spray discharge deflected 75° from inlet axis
  - Coarse atomization
- Spray pattern:** Flat Fan  
**Spray angle:** 105° or 145°, as listed  
**Flow rates:** 0.510 to 757 l/min



Plastic

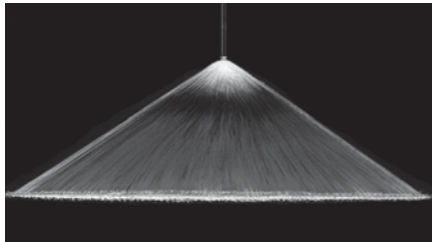

Fan 145°

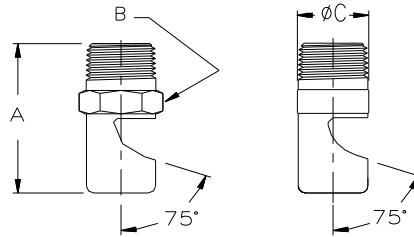

Metal

Plastic

Dimensions are approximate. Check with BETE for critical dimension applications.

### FF Flow Rates

Fan, 105° and 145° Spray Angle, 1/8" to 1" Pipe Sizes, BSP or NPT

Male Pipe Size	Nozzle Number	Spray Angle	K Factor	LITERS PER MINUTE @ BAR								Approx. Orifice Dia. (mm)
				0.2 bar	0.5 bar	0.7 bar	1 bar	2 bar	3 bar	5 bar	10 bar	
1/8	FF016	105°	0.114	0.0510	0.0806	0.0953	0.114	0.161	0.197	0.255	0.360	0.406
	FF024	105°	0.228	0.102	0.161	0.191	0.228	0.322	0.395	0.510	0.721	0.610
	FF028	105°	0.342	0.153	0.242	0.286	0.342	0.483	0.592	0.764	1.08	0.711
	FF033	105°	0.456	0.204	0.322	0.381	0.456	0.645	0.789	1.02	1.44	0.838
	FF041	145°	0.684	0.306	0.483	0.572	0.684	0.967	1.18	1.53	2.16	1.04
	FF046	145°	0.912	0.408	0.645	0.763	0.912	1.29	1.58	2.04	2.88	1.17
	FF052	145°	1.14	0.510	0.806	0.953	1.14	1.61	1.97	2.55	3.60	1.32
	FF057	145°	1.37	0.611	0.967	1.14	1.37	1.93	2.37	3.06	4.32	1.45
1/8 or 1/4	FF065	145°	1.82	0.815	1.29	1.53	1.82	2.58	3.16	4.08	5.77	1.65
	FF073	145°	2.28	1.02	1.61	1.91	2.28	3.22	3.95	5.10	7.21	1.85
	FF093	145°	3.42	1.53	2.42	2.86	3.42	4.83	5.92	7.64	10.8	2.36
	FF104	145°	4.56	2.04	3.22	3.81	4.56	6.45	7.89	10.2	14.4	2.64
	FF116	145°	5.47	2.45	3.87	4.58	5.47	7.73	9.47	12.2	17.3	2.95
	FF125	145°	5.70	2.55	4.03	4.77	5.70	8.06	9.87	12.7	18.0	3.18
	FF129	145°	6.84	3.06	4.83	5.72	6.84	9.67	11.8	15.3	21.6	3.28
	FF141	145°	8.20	3.67	5.80	6.86	8.20	11.6	14.2	18.3	25.9	3.58
FF148	145°	9.12	4.08	6.45	7.63	9.12	12.9	15.8	20.4	28.8	3.76	
1/4	FF156	145°	10.0	4.48	7.09	8.39	10.0	14.2	17.4	22.4	31.7	3.96
	FF161	145°	10.9	4.89	7.73	9.15	10.9	15.5	18.9	24.5	34.6	4.09
	FF173	145°	12.3	5.50	8.70	10.3	12.3	17.4	21.3	27.5	38.9	4.39

$$\text{Flow Rate (l/min)} = K \sqrt{\text{bar}}$$

### FF Dimensions

Pipe Size	Dim. (mm)			Wt. (g)	
	A	B	C	M	P
1/8	25.4	11.2	12.7	14	3
1/4	35.1	14.2	16.0	35	7.5

**Standard Materials:** Brass, 303 Stainless Steel, 316 Stainless Steel, PVC, and PTFE  
 (PTFE and PVC not available in nozzles FF016 to FF028; PTFE not available in nozzles FF033 to FF065).

Spray angle performance varies with pressure. Contact BETE for specific data on critical applications.



Metal



All 3/8" FFs in Brass have UL approval

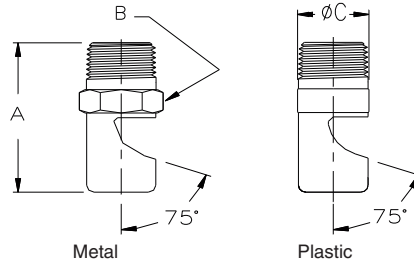

Metal

Plastic

Dimensions are approximate. Check with BETE for critical dimension applications.

FF Flow Rates												FF Dimensions						
Fan, 105° and 145° Spray Angle, 1/8" to 1" Pipe Sizes, BSP or NPT																		
Male Pipe Size	Nozzle Number	Spray Angle	K Factor	LITERS PER MINUTE @ BAR								Approx. Orifice Dia (mm)	Pipe Size	Dim. (mm)			Wt. (g)	
				0.2 bar	0.5 bar	0.7 bar	1 bar	2 bar	3 bar	5 bar	10 bar			A	B	C	M	P
3/8	FF187	145°	13.7	6.11	9.67	11.4	13.7	19.3	23.7	30.6	43.2	4.75	3/8	44.5	17.5	19.1	72	15
	FF196	145°	16.0	7.1	11.3	13.3	16.0	22.6	27.6	35.7	50.4	4.98						
	FF209	145°	17.0	7.6	12.0	14.2	17.0	24.0	29.4	38.0	53.8	5.31						
	FF218	145°	18.2	8.2	12.9	15.3	18.2	25.8	31.6	40.8	57.7	5.54						
	FF221	145°	20.5	9.2	14.5	17.2	20.5	29.0	35.5	45.9	64.9	5.61						
1/2	FF209	145°	17.0	7.6	12.0	14.2	17.0	24.0	29.4	38.0	53.8	5.31	1/2	50.8	22.4	22.4	117	25
	FF218	145°	18.2	8.2	12.9	15.3	18.2	25.8	31.6	40.8	57.7	5.54						
	FF250	145°	23.9	10.7	16.9	20.0	23.9	33.8	41.4	53.5	75.7	6.35						
	FF256	145°	27.3	12.2	19.3	22.9	27.3	38.7	47.4	61.1	86.5	6.55						
	FF281	145°	31.9	14.3	22.6	26.7	31.9	45.1	55.3	71.3	101	7.14						
	FF312	145°	36.5	16.3	25.8	30.5	36.5	51.6	63.2	81.5	115	7.92						
	FF375	145°	54.7	24.5	38.7	45.8	54.7	77.3	94.7	122	173	9.53						
3/4	FF316	145°	41.0	18.3	29.0	34.3	41.0	58.0	71.0	92	130	8.03	3/4	66.8	38.1	38.1	345	73
	FF332	145°	45.6	20.4	32.2	38.1	45.6	64.5	78.9	102	144	8.43						
	FF348	145°	50.1	22.4	35.5	41.9	50.1	70.9	86.8	112	159	8.84						
	FF375	145°	54.7	24.5	38.7	45.8	54.7	77.3	94.7	122	173	9.53						
	FF406	145°	63.8	28.5	45.1	53.4	63.8	90.2	111	143	202	10.3						
	FF437	145°	72.9	32.6	51.6	61.0	72.9	103	126	163	231	11.1						
	FF453	145°	82.0	36.7	58.0	68.6	82.0	116	142	183	259	11.5						
	FF484	145°	95.7	42.8	67.7	80.1	95.7	135	166	214	303	12.3						
	FF500	145°	109	48.9	77.3	91.5	109	155	189	245	346	12.7						
1	FF578	145°	137	61.1	96.7	114	137	193	237	306	432	14.7	1	85.9	50.8	50.8	908	192
	FF625	145°	166	74.4	118	139	166	235	288	372	526	15.9						
	FF703	145°	205	91.7	145	172	205	290	355	459	649	17.9						
	FF750	145°	239	107	169	200	239	338	414	535	757	19.1						

Flow Rate (l/min) = K √bar

Standard Materials: Brass, 303 Stainless Steel, 316 Stainless Steel, PVC, and PTFE

Spray angle performance varies with pressure. Contact BETE for specific data on critical applications.



# EZ FF NF SPN

## EZ Change Quick Connection System

### DESIGN FEATURES

- Nozzles can be changed in seconds without tools
- Three part nozzle, base, gasket and interchangeable tip
- Exclusive ramped engagement for efficient automatic alignment
- Threaded adapters will accommodate other standard BETE nozzles. Shut-off plugs are also available.
- Sanitary EZs are available with weld connection and no knurling

### SPRAY CHARACTERISTICS

- Available in six standard tips: EZFF; EZNF; EZSPN; EZWL; EZTF, and EZWT

#### More EZ tips:

Full Cone: page 38

Hollow Cone: page 54 and 55

**Flow rates:** 0.051 to 125 l/min

#### Spray Angle:

**EZFF:** 105° and 145°

**EZNF:** 0°, 15°, 30°, 50°, 65°, 80°, 90°, 110°, 120°

**EZSPN:** 15°, 25°, 35°, 40° and 50°



EZNF

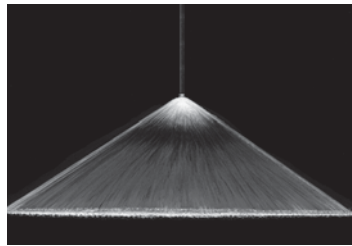

145° Fan

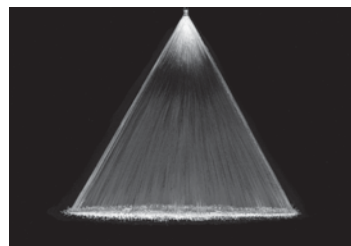

50° Fan

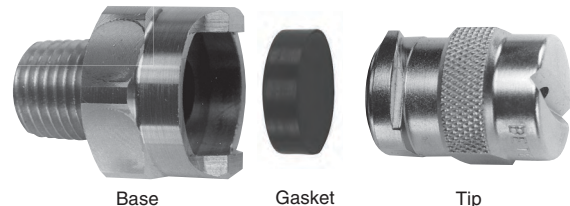

Base

Gasket

Tip

EZNF exploded

Dimensions are approximate. Check with BETE for critical dimension applications.

### EZFF Flow Rates and Dimensions

Deflected Flat Fan 105° and 145° Spray Angles 1/8" to 1/2" BSP or NPT

Pipe Size	Nozzle Number	K Factor	LITERS PER MINUTE @ BAR							Approx. Orifice Dia. (mm)	Pipe Size	Approx. Assembly Dim. (mm) Hex Length	Wt. (g)				
			0.2 bar	0.5 bar	0.7 bar	1 bar	2 bar	3 bar	5 bar								
1/8"	EZFF016*	0.114	0.051	0.081	0.095	0.114	0.161	0.197	0.255	0.406	1/8	22.4 41.4	62				
	EZFF024*	0.228	0.102	0.161	0.191	0.228	0.322	0.395	0.510	0.610							
	EZFF028*	0.342	0.153	0.242	0.286	0.342	0.483	0.592	0.764	0.711							
	EZFF033*	0.456	0.204	0.322	0.381	0.456	0.645	0.789	1.02	0.838							
	EZFF041	0.684	0.306	0.483	0.572	0.684	0.967	1.18	1.53	1.04							
	EZFF046	0.912	0.408	0.645	0.763	0.912	1.29	1.58	2.04	1.17							
	EZFF052	1.14	0.510	0.806	0.953	1.14	1.61	1.97	2.55	1.32							
	EZFF057	1.37	0.611	0.967	1.14	1.37	1.93	2.37	3.06	1.45							
	EZFF065	1.82	0.815	1.29	1.53	1.82	2.58	3.16	4.08	1.65							
TO	EZFF073	2.28	1.02	1.61	1.91	2.28	3.22	3.95	5.10	1.85	1/4"	22.4 44.5	62				
	EZFF093	3.42	1.53	2.42	2.86	3.42	4.83	5.92	7.64	2.36							
	EZFF104	4.56	2.04	3.22	3.81	4.56	6.45	7.89	10.2	2.64							
	EZFF116	5.47	2.45	3.87	4.58	5.47	7.73	9.47	12.2	2.95							
	EZFF125	5.70	2.55	4.03	4.77	5.70	8.06	9.87	12.7	3.18							
	EZFF129	6.84	3.06	4.83	5.72	6.84	9.67	11.8	15.3	3.28							
	EZFF141	8.20	3.67	5.80	6.86	8.20	11.6	14.2	18.3	3.58							
	EZFF148	9.12	4.08	6.45	7.63	9.12	12.9	15.8	20.4	3.76							
	EZFF156	10.0	4.48	7.09	8.39	10.0	14.2	17.4	22.4	3.96							
1/2"	EZFF161	10.9	4.89	7.73	9.15	10.9	15.5	18.9	24.5	4.09	3/8"	22.4 46.0	74				
	EZFF173	12.3	5.50	8.70	10.3	12.3	17.4	21.3	27.5	4.39							
	EZFF187	13.7	6.11	9.67	11.4	13.7	19.3	23.7	30.6	4.75							
	EZFF196	16.0	7.13	11.3	13.3	16.0	22.6	27.6	35.7	4.98							
	1/4"	EZFF218	18.2	8.15	12.9	15.3	18.2	25.8	31.6	40.8				5.31	1/2"	22.4 47.5	82
	TO	EZFF221	20.5	9.17	14.5	17.2	20.5	29.0	35.5	45.9				5.61			
1/2"	EZFF250	23.9	10.7	16.9	20.0	23.9	33.8	41.4	53.5	6.35	1/2"	22.4 47.5	82				
	EZFF256	27.3	12.2	19.3	22.9	27.3	38.7	47.4	61.1	6.55							

Flow Rate (l/min) =  $K \sqrt{\text{bar}}$

\*Available in 105° only; all others 145°

Standard Materials: 303 Stainless Steel, 316 Stainless Steel, and Brass; Viton gaskets standard.

Spray angle performance varies with pressure. Contact BETE for specific data on critical applications.

TO ORDER: specify pipe size, connection type, nozzle number, spray angle, and material.

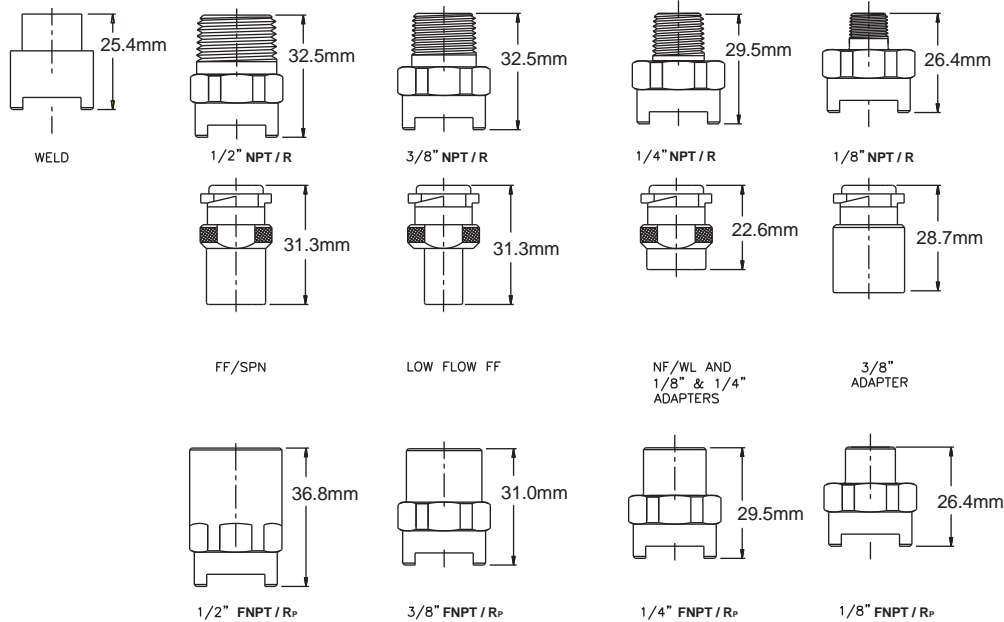

Dimensions are approximate. Check with BETE for critical dimension applications.

### EZNF Flow Rates and Dimensions

Fan and Straight Jet 0°, 15°, 30°, 50°, 65°, 80°, 90°, 110° and 120° Spray Angles 1/8" to 1/2" BSP or NPT

Pipe Size	Nozzle Number	K Factor	LITERS PER MINUTE @ BAR											Equivalent Orifice Dia. (mm)	Approx. Assembly Dim. (mm)		Wt. (g)			
			0.2 bar	0.5 bar	0.7 bar	1 bar	2 bar	3 bar	5 bar	10 bar	15 bar	20 bar	30 bar		35 bar	Hex		Length		
1/8" TO	EZNF01	0.228		0.161	0.191	0.228	0.322	0.394	0.509	0.720	0.882	1.02	1.25	1.35	0.660	1/8"	22.4	41.4	62	
	EZNF015	0.342		0.242	0.286	0.342	0.483	0.592	0.764	1.08	1.32	1.53	1.87	2.02	0.787					
	EZNF02	0.455		0.322	0.381	0.455	0.644	0.789	1.02	1.44	1.76	2.04	2.49	2.69	0.914					
	EZNF025	0.569		0.403	0.476	0.569	0.805	0.986	1.27	1.80	2.20	2.55	3.12	3.37	1.02					
	EZNF03	0.683		0.483	0.572	0.683	0.966	1.18	1.53	2.16	2.65	3.06	3.74	4.04	1.09	1/4"	22.4	44.5	62	
	EZNF04	0.911		0.644	0.762	0.911	1.29	1.58	2.04	2.88	3.53	4.07	4.99	5.39	1.32					
	EZNF05	1.14		0.806	0.953	1.14	1.61	1.97	2.55	3.60	4.41	5.10	6.24	6.74	1.45					
	EZNF06	1.37	0.612	0.967	1.14	1.37	1.93	2.37	3.06	4.33	5.30	6.12	7.49	8.09	1.57					
	1/2"	EZNF08	1.82	0.812	1.28	1.52	1.82	2.57	3.15	4.06	5.74	7.03	8.12	9.95	10.7	1.83	3/8"	22.4	46.0	74
		EZNF10	2.28	1.02	1.61	1.91	2.28	3.22	3.95	5.10	7.21	8.83	10.2	12.5	13.5	2.03				
EZNF15		3.42	1.53	2.42	2.86	3.42	4.83	5.92	7.64	10.8	13.2	15.3	18.7	20.2	2.38					
EZNF20		4.56	2.04	3.22	3.81	4.56	6.45	7.89	10.2	14.4	17.7	20.4	25.0	27.0	2.78					
EZNF30		6.84	3.06	4.83	5.72	6.84	9.67	11.8	15.3	21.6	26.5	30.6	37.4	40.4	3.57					
EZNF40		9.12	4.08	6.45	7.63	9.12	12.9	15.8	20.4	28.8	35.3	40.8	49.9	53.9	3.97					
EZNF50		11.4	5.10	8.06	9.53	11.4	16.1	19.7	25.5	36.0	44.1	51.0	62.4	67.4	4.37					
EZNF60		13.7	6.11	9.67	11.4	13.7	19.3	23.7	30.6	43.2	53.0	61.1	74.9	80.9	4.76					
1/4" -1/2"	EZNF80	18.2	8.15	12.9	15.3	18.2	25.8	31.6	40.8	57.7	70.6	81.5	99.9	108	5.56	1/2"	22.4	47.5	82	
	EZNF90	20.5	9.17	14.5	17.2	20.5	29.0	35.5	45.9	64.9	79.4	91.7	112	121	5.95					

$$\text{Flow Rate (l/min)} = K \sqrt{\text{bar}}$$

Standard Materials: 303 Stainless Steel, 316 Stainless Steel, and Brass; Viton gaskets standard.

### EZSPN Flow Rates and Dimensions

Fan 15°, 25°, 35°, 40° and 50° Spray Angles 1/8" to 1/2" BSP or NPT

Pipe Size	Nozzle Number	Available Spray Angle			K Factor	LITERS PER MINUTE @ BAR											Equiv. Orifice Dia (mm)	Deflection Angle @ Spray Angle					Approx. Assembly Dim. (mm)		Wt. (g)			
		15°	25°	35°		0.3 bar	0.5 bar	0.7 bar	1 bar	2 bar	3 bar	5 bar	7 bar	10 bar	15 bar	20 bar		30 bar	15°	25°	35°	40°	50°	Hex		Length		
1/8" TO	EZSPN10	15°	35°	50°	2.28	1.25	1.61	1.91	2.28	3.22	3.95	4.56	5.10	7.21	8.83	10.2	12.5	1.98	5°	35°	55°	1/8"	22.4	41.4	82			
	EZSPN20	15°	35°	50°	4.56	2.50	3.22	3.81	4.56	6.45	7.89	9.12	10.2	14.4	17.7	20.4	25.0	2.77	5°	35°	45°							
	EZSPN25				5.70	3.12	4.03	4.77	5.70	8.06	9.87	11.4	12.7	18.0	22.1	25.5	31.2	3.05			50°							
1/2"	EZSPN30	15°	35°		6.84	3.74	4.83	5.72	6.84	9.67	11.8	13.7	15.3	21.6	26.5	30.6	37.4	3.18	5°	28°		1/4"	22.4	44.5	82			
	EZSPN40	15°	25°	35°	40°	50°	9.12	4.99	6.45	7.63	9.12	12.9	15.8	18.2	20.4	28.8	35.3	40.8	49.9	3.96	5°					20°	35°	35°
1/4" TO	EZSPN50			35°	40°	11.4	6.24	8.06	9.53	11.4	16.1	19.7	22.8	25.5	36.0	44.1	51.0	62.4	4.34	23°	33°		3/8"	22.4	46.0	98		
	EZSPN60	15°	35°	40°	50°	13.7	7.49	9.67	11.4	13.7	19.3	23.7	27.3	30.6	43.2	53.0	61.1	74.9	4.75	5°	20°	33°					35°	
	EZSPN70			40°		16.0	8.74	11.3	13.3	16.0	22.6	27.6	31.9	35.7	50.4	61.8	71.3	87.4	5.05		29°							
1/2"	EZSPN80	15°	35°	40°	50°	18.2	9.99	12.9	15.3	18.2	25.8	31.6	36.5	40.8	57.7	70.6	81.5	99.9	5.31	5°	25°	26°	35°	1/2"	22.4	47.5	109	
	EZSPN90			40°		20.5	11.2	14.5	17.2	20.5	29.0	35.5	41.0	45.9	64.9	79.4	91.7	112	5.54		28°							
1/2"	EZSPN100	15°	35°	40°	50°	22.8	12.5	16.1	19.1	22.8	32.2	39.5	45.6	51.0	72.1	88.3	102	125	5.94	5°	25°	28°	40°					

$$\text{Flow Rate (l/min)} = K \sqrt{\text{bar}}$$

Standard Materials: 303 Stainless Steel, 316 Stainless Steel, and Brass; Viton gaskets standard.

Spray angle performance varies with pressure. Contact BETE for specific data on critical applications.



Call for the name of your nearest BETE representative.  
CALL 413-772-0846

# SF

## Snap Release Nozzle System

### DESIGN FEATURES

- Nozzles can be quickly changed and aligned by hand without tools
- Clamp-on adapter fits any style nozzle
- Quick set-up system features special "Snap-in" tips
- Polypropylene, resistant to most acids and alkalies
- Double clamp base or adapter available for higher pressure operation

### SPRAY CHARACTERISTICS

- Quick Set-up System can be provided with fan, hollow or full cone spray tips
- Full 45° alignment of spray without tools

#### More SF Nozzle Systems:

Full Cone: page 39

Hollow Cone: page 56

**Flow rates:** 1.61 to 75.6 l/min

#### Spray angles:

**Fan:** 40°, 50°, 65°, 80°, 95°

**Hollow Cone:** 50°, 65°, 90°

**Full Cone:** 35°, 65°, 80°

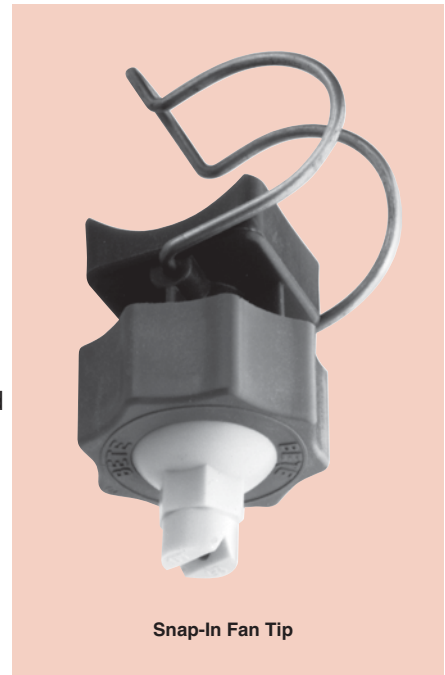

Snap-In Fan Tip

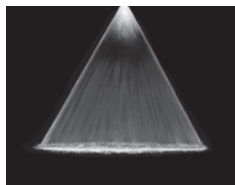

50° Fan

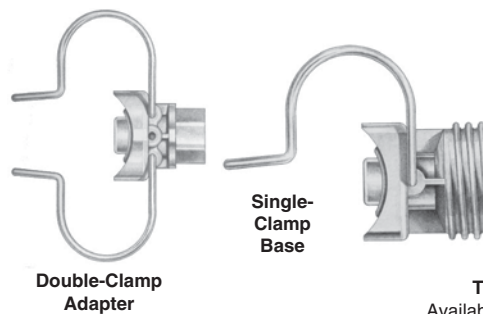
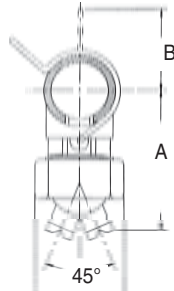

Double-Clamp Adapter

Single-Clamp Base

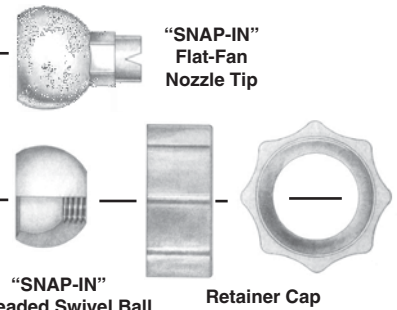

"SNAP-IN" Flat-Fan Nozzle Tip

"SNAP-IN" Threaded Swivel Ball

Retainer Cap

Available with 1/8", 1/4", 3/8", 1/2" NPT or BSP Female threads

### CLAMP-ON ADAPTER

- Available for 1", 1-1/4", 1-1/2" and 2" pipe.
- Available with 1/8", 1/4", 3/8", 1/2" NPT female or 1/8" BSP female threads
- Available with single or double clamp.

### TO ORDER ADAPTER

Specify: Pipe Size, thread size, thread type, number of clamps, materials.

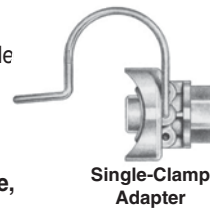

Single-Clamp Adapter

### SF Flow Rates and Dimensions

SF Fan 40°, 50°, 65°, 80° and 90° Spray Angles 1", 1-1/4", 1-1/2" and 2"

Nozzle Number	Available Spray Angles	K Factor	LITERS PER MINUTE @ BAR									Approx. Orifice Dia. (mm)	Pipe Size	Body Color	Pipe O.D. (mm)	Approx. Dim. (mm)		Wt. (g)
			0.5 bar	0.7 bar	1 bar	2 bar	3 bar	5 bar	7 bar	10 bar	A					B		
SF10	80°	2.277	1.61	1.91	2.28	3.22	3.94	5.09	6.03	7.20	2.0	1"	blue	33.40	83.8	43.2	62.4	
SF20	65°	4.556	3.22	3.81	4.55	6.44	7.89	10.2	12.1	14.4	2.8	1-1/4"	red	42.16	86.4	48.3	62.4	
SF30	65°	6.832	4.83	5.72	6.83	9.66	11.8	15.3	18.1	21.6	3.6							
SF40	65°	9.109	6.44	7.62	9.11	12.9	15.8	20.4	24.1	28.8	4.0	1-1/2"	purple	48.26	91.4	50.8	62.4	
SF50	40° 50° 65°	11.40	8.06	9.54	11.4	16.1	19.7	25.5	30.2	36.1	4.4							
SF60	50° 65° 80° 95°	13.68	9.67	11.4	13.7	19.3	23.7	30.6	36.2	43.3	4.8	2"	green	60.33	94.0	55.9	62.4	
SF70	50° 80°	16.00	11.3	13.4	16.0	22.6	27.7	35.8	42.3	50.6	5.2							
SF100	50°	22.7	16.1	19.1	22.8	32.2	39.4	50.9	60.3	72.0	6.4							

$$\text{Flow Rate (l/min)} = K \sqrt{\text{bar}}$$

**Standard Materials:** Polypropylene, 302 Stainless Steel clamp, EPDM seal.

**Optional Materials:** Viton seal.

**NOTE:** Drill 16.7mm (21/32") hole in pipe to install SF.

**NOTE:** Maximum recommended pressures for SF assemblies: With single clamp 5 bar for 1" pipe; 3.5 bar for 1-1/4" and 1-1/2" pipe; and 2 bar for 2" pipe; with double clamp up to 10 bar.

Spray angle performance varies with pressure. Contact BETE for specific data on critical applications.

TO ORDER: specify pipe size, connection type, nozzle number, spray angle, and material.

# SPN

## High Impact/Narrow Fan Spray

### DESIGN FEATURES

- One-piece/heavy construction
- Straight-through orifice minimizes clogging
- Machined from bar stock to exacting standards
- Male connection

### SPRAY CHARACTERISTICS

- Yields highest impact, narrow, flat spray with least atomization
- Spoon-shaped deflector surface efficiently forms a hard driving spray

Spray pattern: Fan

Spray angles: 15°, 25°, 35°, 40°, 50°

Flow rates: 0.76 to 177 l/min

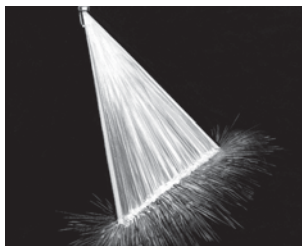
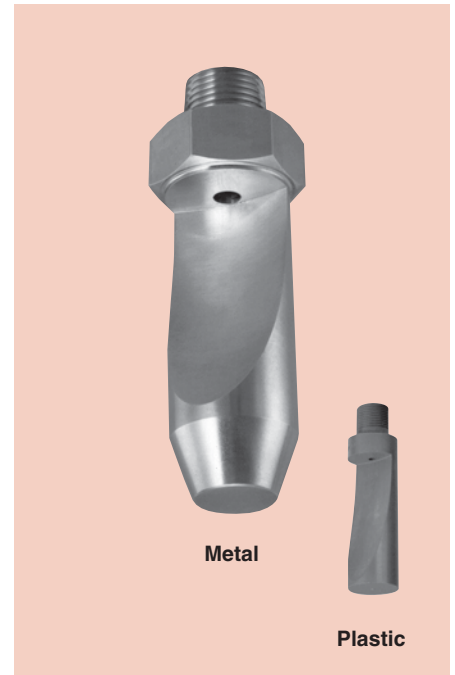

Fan 50°

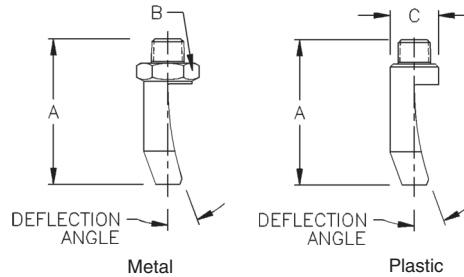

Dimensions are approximate. Check with BETE for critical dimension applications.

### SPN Flow Rates and Dimensions

Fan, 15°, 25°, 35°, 40° and 50° Spray Angles, 1/4" to 3/4" Pipe Sizes, BSP or NPT

Male Pipe Size	Nozzle Number	Available Spray Angles	K Factor	LITERS PER MINUTE @ BAR								Approx. Orifice Dia. (mm)	Deflection Angle @ Spray Angle	Dimensions (mm)			Mass (g) Metal
				0.7 bar	1 bar	2 bar	3 bar	4 bar	5 bar	10 bar	15 bar			Metals Only	A	B	
1/8	SPN 04	35°	0.91	0.76	0.91	1.29	1.58	1.82	2.04	2.88	3.53	1.24	15°	17.8	12.7	14.2	14.1
1/4	SPN 10	15° 35° 50°	2.28	1.91	2.28	3.22	3.95	4.56	5.10	7.21	8.83	1.98	5° 35° 55°	50.8	22.4	19.1	70.9
	SPN 20	15° 35° 50°	4.56	3.81	4.56	6.45	7.89	9.12	10.2	14.4	17.7	2.77	5° 35° 45°				
	SPN 25	50°	5.70	4.77	5.70	8.06	9.87	11.4	12.7	18.0	22.1	3.05	50°				
	SPN 40	25° 50°	9.12	7.63	9.12	12.9	15.8	18.2	20.4	28.8	35.3	3.96	20° 45°				
3/8	SPN 20	35°	4.56	3.81	4.56	6.45	7.89	9.12	10.2	14.4	17.7	2.77	30°	76.2	28.7	25.4	227
	SPN 25	35°	5.70	4.77	5.70	8.06	9.87	11.4	12.7	18.0	22.1	3.05	5° 28° 45°				
	SPN 30	15° 35°	6.84	5.72	6.84	9.67	11.8	13.7	15.3	21.6	26.5	3.18	5° 28°				
	SPN 40	15° 35° 40° 50°	9.12	7.63	9.12	12.9	15.8	18.2	20.4	28.8	35.3	3.96	5° 35° 35° 50°				
	SPN 50	35° 40°	11.4	9.53	11.4	16.1	19.7	22.8	25.5	36.0	44.1	4.34	23° 33°				
	SPN 60	15° 35° 40° 50°	13.7	11.4	13.7	19.3	23.7	27.3	30.6	43.2	53.0	4.75	5° 20° 33° 35°				
	SPN 70	40°	16.0	13.3	16.0	22.6	27.6	31.9	35.7	50.4	61.8	5.16	29°				
	SPN 80	15° 35° 40° 50°	18.2	15.3	18.2	25.8	31.6	36.5	40.8	57.7	70.6	5.31	5° 25° 26° 35°				
	SPN 90	40°	20.5	17.2	20.5	29.0	35.5	41.0	45.9	64.9	79.4	5.54	28°				
	SPN 100	15° 35° 40° 50°	22.8	19.1	22.8	32.2	39.5	45.6	51.0	72.1	88.3	5.94	5° 25° 28° 40°				
	SPN 120	15° 35° 50°	27.3	22.9	27.3	38.7	47.4	54.7	61.1	86.5	106	7.14	5° 25° 40°				
	SPN 125	50°	28.5	23.8	28.5	40.3	49.3	57.0	63.7	90.1	110	6.76	38°				
SPN 160	50°	36.5	30.5	36.5	51.6	63.2	72.9	81.5	115	141	7.54	25° 37°					
SPN 200	50°	45.6	38.1	45.6	64.5	78.9	91.2	102	144	177	8.33	32°					
1/2	SPN 60	15° 35°	13.7	11.4	13.7	19.3	23.7	27.3	30.6	43.2	53.0	4.75	5° 27°	114	35.1	31.8	539
	SPN 80	15° 35° 50°	18.2	15.3	18.2	25.8	31.6	36.5	40.8	57.7	70.6	5.31	5° 25°				
	SPN 100	15° 35°	22.8	19.1	22.8	32.2	39.5	45.6	51.0	72.1	88.3	5.94	5° 19°				
	SPN 140	15° 35° 50°	31.9	26.7	31.9	45.1	55.3	63.8	71.3	101	124	7.52	5° 25° 40°				
	SPN 160	15° 35° 50°	36.5	30.5	36.5	51.6	63.2	72.9	81.5	115	141	7.92	5° 25° 40°				
3/4	SPN 160	35°	36.5	30.5	36.5	51.6	63.2	72.9	81.5	115	141	7.92	23°	124	44.5	42.9	850
	SPN 200	15° 35°	45.6	38.1	45.6	64.5	78.9	91.2	102	144	177	8.33	5° 22°				

Flow Rate (l/min) = K√bar

Standard Materials: Brass, 303 Stainless Steel, 316 Stainless Steel, PVC, and PTFE

Spray angle performance varies with pressure. Contact BETE for specific data on critical applications.

Call for the name of your nearest BETE representative.  
CALL 413-772-0846



# MicroWhirl®

## Fine Atomization

### DESIGN FEATURES

- Outstanding atomization
- Rugged pinless design
- Drip-free performance
- Standard: 70 micron polypropylene filter
  - Optional: 200-mesh 316SS screen
- Safety wire hole available
- Patented design
- Minimum operating pressure 7 bar

### SPRAY CHARACTERISTICS

- Mist at low pressure; fog at high pressure

**Spray pattern:** Cone-shaped Fog

**Flow rates:** 0.032 to 1.413 L/min



MISTING

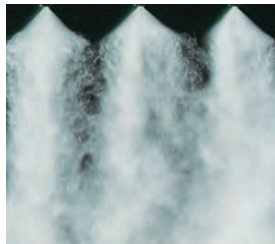

Fog

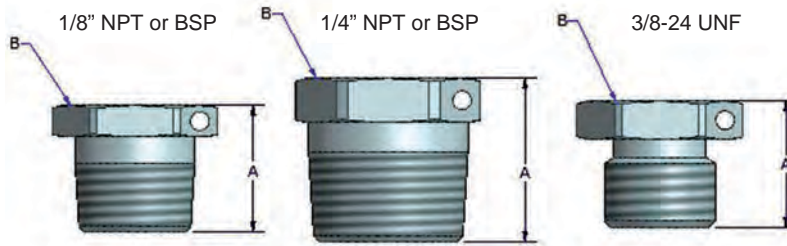

Shown with optional 1.59mm (1/16") diameter safety wire hole

Dimensions (mm)

Pipe Size	A	B
1/8"	12.3	11.1
1/4"	17.5	14.3
3/8-24UNF	10.8	12.7

Dimensions are approximate. Check with BETE for critical dimension applications.

### MicroWhirl Flow Rates and Dimensions

Fogging, 70° Spray Angle, 1/8", 1/4" BSP or NPT or 3/8" - 24 UNF Pipe Sizes

Male Pipe Size	Nozzle Number	K Factor	LITERS PER MINUTE @ BAR								Wt (g)
			7 bar	20 bar	40 bar	70 bar	100 bar	140 bar	170 bar	200 bar	
1/8"	MW085	0.0122	0.032	0.055	0.077	0.102	0.122	0.145	0.160	0.173	7.09
	MW105	0.0151	0.040	0.068	0.096	0.127	0.151	0.179	0.197	0.214	
	or MW125	0.0180	0.048	0.081	0.114	0.151	0.180	0.213	0.235	0.255	
1/4"	MW145	0.0209	0.055	0.093	0.132	0.175	0.209	0.247	0.272	0.296	
	or MW195	0.0281	0.074	0.126	0.178	0.235	0.281	0.332	0.366	0.397	
3/8"-24UNF	MW275	0.0396	0.105	0.177	0.251	0.332	0.396	0.469	0.517	0.560	
	MW695	0.09988	0.264	0.447	0.632	0.836	0.999	1.182	1.302	1.413	

Nominal Angle

Atomization Level



→ Pattern with increasing pressure from nozzle →

$$\text{Flow Rate (l/min)} = K \sqrt{\text{bar}}$$

Standard Materials: 303 and 316 Stainless Steel, Polypropylene filter, and Viton O-ring seal\* (\*supplied for 3/8"-24 UNF connection)

Spray angle performance varies with pressure. Contact BETE for specific data on critical applications.

TO ORDER: specify pipe size, connection type, nozzle number, spray angle, and material.

# PJ

## Smallest Physical Size

### DESIGN FEATURES

- High energy efficiency
- One-piece, compact construction
- No whirl vanes or internal parts
- 1/8" or 1/4" male connection
- Standard: 100-mesh 316SS screen
  - Optional: 200-mesh 316SS screen
  - Optional: 20 micron paper filter
  - Optional: 70 micron polypropylene filter
- Optional welded pin and optional safety wire hole

### SPRAY CHARACTERISTICS

- Finest fog of any direct pressure nozzle

**Spray pattern:** Cone-shaped Fog

**Spray angle:** 90°. For best 90° pattern operate nozzle at or above 4 bar

**Flow rates:** 0.043 to 5.34 L/min



MISTING



Fog

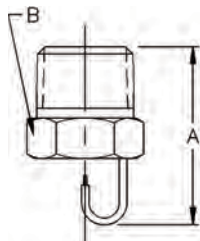

Male

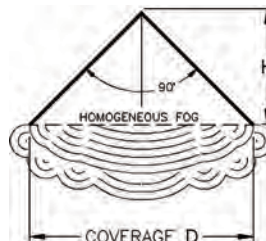

Fog Pattern

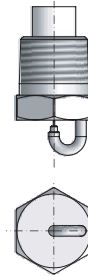

PJ with polypropylene filter

Dimensions are approximate. Check with BETE for critical dimension applications.

### PJ Flow Rates and Dimensions

Impingement, 90° Spray Angle, 1/8" or 1/4" Pipe Sizes, BSP or NPT

Male Pipe Size	Nozzle Number	K Factor	LITERS PER MINUTE @ BAR							Approx. Orifice Dia. (mm)	Approx. Cov. D (mm)	Approx. Spray Height H (mm)	Pipe Size	Dim. (mm)		Wt. (g) Metal	
			2 bar	3 bar	5 bar	10 bar	20 bar	30 bar	50 bar					70 bar	A		B
1/8	PJ6	0.0137			0.031	0.043	0.061	0.075	0.097	0.114	0.152	203	103	1/8	19.1	11.1	7
	PJ8	0.0259			0.058	0.082	0.116	0.142	0.183	0.217	0.203	254	127				
	PJ10	0.0387		0.067	0.087	0.123	0.173	0.212	0.274	0.324	0.254	254	127				
	PJ12	0.0524		0.091	0.117	0.166	0.234	0.287	0.371	0.439	0.305	254	127				
	PJ15	0.0843	0.119	0.146	0.189	0.267	0.377	0.462	0.596	0.705	0.381	254	127				
OR	PJ20	0.153	0.216	0.264	0.341	0.483	0.683	0.836	1.08	1.28	0.508	310	155	1/4	24.6	14.2	
	PJ24	0.228	0.322	0.395	0.510	0.721	1.02	1.25	1.61	1.91	0.610	400	200				
	PJ28	0.296	0.419	0.513	0.662	0.937	1.32	1.62	2.09	2.48	0.711	460	230				
1/4	PJ32	0.410	0.580	0.710	0.917	1.297	1.83	2.25	2.90	3.43	0.813	560	280				
	PJ40	0.638	0.902	1.11	1.43	2.02	2.85	3.49	4.51	5.34	1.02	610	305				

$$\text{Flow Rate (L/min)} = K \sqrt{\text{bar}}$$

Standard Materials: Brass, 303 Stainless Steel, and 316 Stainless Steel

Spray angle performance varies with pressure. Contact BETE for specific data on critical applications.

# P

## Fine Atomization

### DESIGN FEATURES

- High energy efficiency
- No whirl vanes or internal parts
- Highly efficient laminar jet impinges on target pin generating fine fog
- Male connection

### SPRAY CHARACTERISTICS

- Finest fog of any direct pressure nozzle

**Spray pattern:** Cone-shaped Fog

**Spray angle:** 90°. For best 90° pattern operate nozzle at or above 4 bar

**Flow rates:** 0.153 to 30.3 l/min



MISTING



Fog

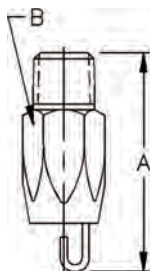

Male

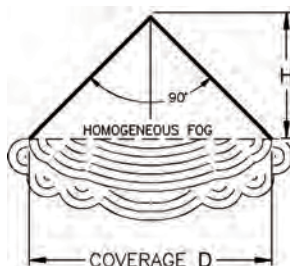

Fog Pattern

Dimensions are approximate. Check with BETE for critical dimension applications.

### P Flow Rates and Dimensions

Cone-Shaped Fog, 90° Spray Angle, 1/4" Pipe Size, BSP or NPT

Male Pipe Size	Nozzle Number	K Factor	LITERS PER MINUTE @ BAR								Approx. Orifice Dia. (mm)	Approx. Coverage D (mm)	Approx. Spray Height H (mm)	Approx. Dim. (mm)		Wt. (g) Metal
			1 bar	2 bar	3 bar	5 bar	7 bar	10 bar	20 bar	30 bar				A	B	
1/4	P20	0.153	0.153	0.216	0.264	0.341	0.404	0.483	0.683	0.836	0.508	300	150	46.5	16.0	57
	P24	0.228	0.228	0.322	0.395	0.510	0.603	0.721	1.02	1.25	0.610	400	200			
	P28	0.296	0.296	0.419	0.513	0.662	0.784	0.937	1.32	1.62	0.711	460	230			
	P32	0.410	0.410	0.580	0.710	0.917	1.09	1.30	1.83	2.25	0.813	560	280			
	P40	0.638	0.638	0.902	1.11	1.43	1.69	2.02	2.85	3.49	1.02	610	305			
	P48	0.912	0.912	1.29	1.58	2.04	2.41	2.88	4.08	4.99	1.22	710	355			
	P54	1.21	1.21	1.71	2.09	2.70	3.20	3.82	5.40	6.62	1.37	760	380			
	P66	1.71	1.71	2.42	2.96	3.82	4.52	5.40	7.64	9.36	1.68	910	455			
	P80	2.46	2.46	3.48	4.26	5.50	6.51	7.78	11.0	13.5	2.03	1200	600			
	P120	5.54	5.54	7.83	9.59	12.4	14.7	17.5	24.8	30.3	3.05	1500	750			

$$\text{Flow Rate (l/min)} = K \sqrt{\text{bar}}$$

Standard Materials: Brass, 303 Stainless Steel, and 316 Stainless Steel

Spray angle performance varies with pressure. Contact BETE for specific data on critical applications.

TO ORDER: specify pipe size, connection type, nozzle number, spray angle, and material.

# L

## Low Flow

### DESIGN FEATURES

- A series of small spiral nozzles with orifice diameters of 1.02mm to 3.05mm
- Male connection

### SPRAY CHARACTERISTICS

**Spray pattern:** Hollow Cone Fog, nearly as fine as P Series  
**Spray angles:** 90° standard (120° available by special order)  
**Flow rates:** 0.534 to 14.7 l/min



MISTING

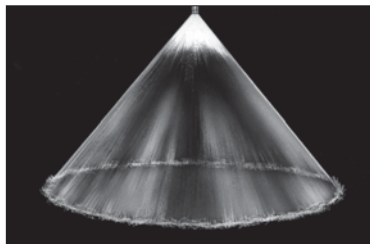

Hollow Cone 90°

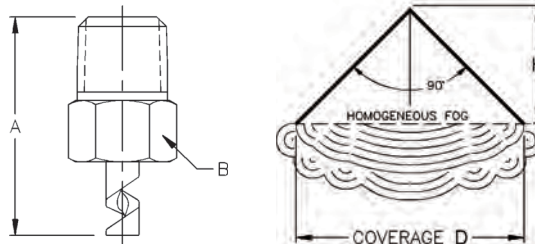

Fog Pattern

Dimensions are approximate. Check with BETE for critical dimension applications.

### L Flow Rates

Hollow Cone, 90° Spray Angle, 1/8" and 1/4" Pipe Sizes, BSP or NPT

Male Pipe Size	Nozzle Number	K Factor	LITERS PER MINUTE @ BAR								Approx. Orifice Dia. (mm)	Spray Dimensions (mm)	
			0.7 bar	1 bar	1.5 bar	2 bar	3 bar	4 bar	5 bar	7 bar		D	H
1/8	L40	0.638	0.534	0.638	0.781	0.902	1.11	1.28	1.43	1.69	1.02	610	305
	L48	0.912	0.76	0.91	1.12	1.29	1.58	1.82	2.04	2.41	1.22	690	345
	L54	1.21	1.01	1.21	1.48	1.71	2.09	2.42	2.70	3.20	1.37	760	380
	L66	1.71	1.43	1.71	2.09	2.42	2.96	3.42	3.82	4.52	1.68	910	455
1/4	L80	2.46	2.06	2.46	3.01	3.48	4.26	4.92	5.50	6.51	2.03	1200	600
	L120	5.54	4.63	5.54	6.78	7.83	9.59	11.1	12.4	14.7	3.05	1500	750

$$\text{Flow Rate (l/min)} = K \sqrt{\text{bar}}$$

Standard Materials: Brass, 303 Stainless Steel, 316 Stainless Steel, and PTFE (L40, L48, L54 not available in PTFE)

Spray angle performance varies with pressure. Contact BETE for specific data on critical applications.

### L Dimensions BSP or NPT

Male Pipe Size	Dimensions (mm)		Wt. (g) Metal
	A	B	
1/8"	28.4	14.3	17
1/4"	33.3	14.3	21

CALL 413-772-0846  
 Call for the name of your nearest BETE representative.



# UltiMist®

## Misting Nozzles

### DESIGN FEATURES

#### Metal:

- 416 Stainless Steel tip
- Brass adapter
- 1/8" and 1/4" sizes
- Male or female connections
- Integral 100 mesh strainer

#### Plastic:

- All plastic construction
- 1/8" male connection

### SPRAY CHARACTERISTICS

- Very fine, fog-like mist
- Produces high number of droplets under 60 microns

**Spray pattern:** Hollow Cone  
Medium angle

**Flow rates:** Metal - (1.5 - 61.1 L/hr)  
Plastic - (2.5 - 32.6 L/hr)

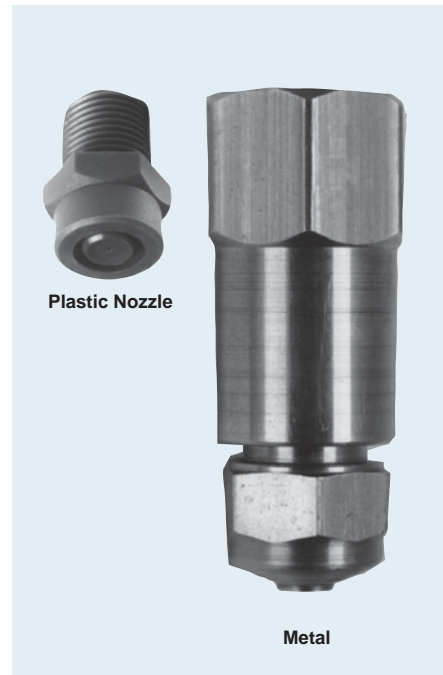

Plastic Nozzle

Metal

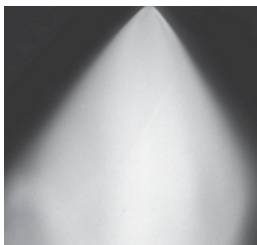

Mist

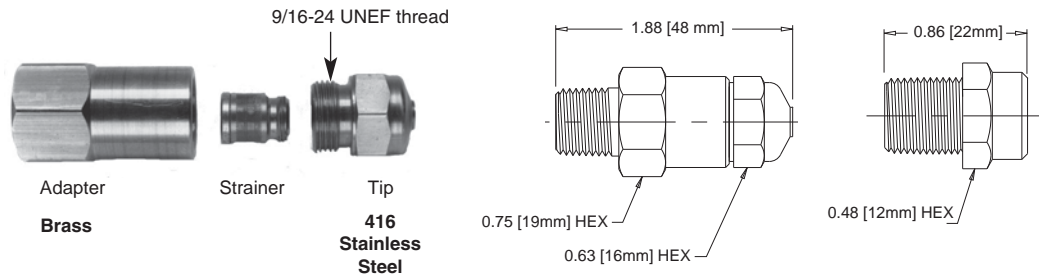

Dimensions are approximate. Check with BETE for critical dimension applications.

### UltiMist Metal Flow Rates and Dimensions Hollow Cone, Medium Spray Angle, 1/8" and 1/4" Pipe Sizes

NPT, BSP Male or Female Pipe Size	Nozzle Number	K Factor	LITERS PER HOUR @ BAR				
			3 bar	10 bar	40 bar	70 bar	80 bar
1/8	UM37M	0.84	1.5	2.7	5.3	7.1	7.5
	UM50M	1.14	2.0	3.6	7.2	9.5	10.2
	UM75M	1.71	3.0	5.4	10.8	14.3	15.3
or	UM100M	2.28	3.9	7.2	14.4	19.1	20.4
	UM150M	3.42	5.9	10.8	21.6	28.6	30.6
	UM200M	4.56	7.9	14.4	28.8	38.1	40.8
1/4	UM250M	5.70	9.9	18.0	36.0	47.7	51.0
	UM300M	6.84	11.8	21.6	43.2	57.2	61.1

Flow Rate (l/hr) =  $K \sqrt{\text{bar}}$

Standard Material: 416 Stainless Steel Tip, Brass Adapter/Body

### UltiMist Plastic Flow Rates Hollow Cone, Medium Spray Angle, 1/8" Pipe Size

NPT Male Pipe Size	Nozzle Number	K Factor	LITERS PER HOUR @ BAR				
			3 bar	5 bar	10 bar	20 bar	70 bar
1/8	UML63M	1.44	2.5	3.2	4.6	6.4	12.1
	UML126M	2.88	5.0	6.4	9.1	12.9	24.1
	UML170M	3.89	6.7	8.7	12.3	17.4	32.6

Flow Rate (l/hr) =  $K \sqrt{\text{bar}}$

Standard Material: Polyacetal

Spray angle performance varies with pressure. Contact BETE for specific data on critical applications.

MISTING

TO ORDER: specify pipe size, connection type, nozzle number, spray angle, and material.

# SS

## Small Droplet Size Dense Mist

### DESIGN FEATURES

- Multiple flat fan patterns
- Solid one-piece construction
- Female connection

### SPRAY CHARACTERISTICS

- Relatively small droplets
- Spray pattern:** Dense Full Cone  
**Flow rates:** 9.16 to 618 l/min  
**Spray angles:**  
**SS4.8 thru SS25** - 35°  
**SS35 thru SS70** - 45°



Fog

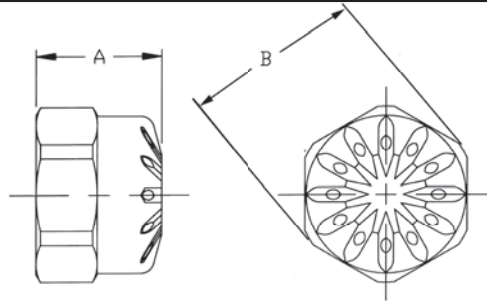

Dimensions are approximate. Check with BETE for critical dimension applications.

### SS Flow Rates and Dimensions

Full Cone, 3/4", 1" and 1-1/4" Pipe Size, BSP or NPT

Female Pipe Size	Nozzle Number	K Factor	LITERS PER MINUTE @ BAR							Dimensions (mm)		Wt. (g)
			0.7 bar	1 bar	2 bar	3 bar	5 bar	10 bar	15 bar	A	B	
3/4	SS4.8	10.9	9.16	10.9	15.5	19.0	24.5	34.6	42.4	25.4	35.1	85.1
	SS9	20.5	17.2	20.5	29.0	35.6	45.9	64.9	79.5			
	SS12	27.4	22.9	27.4	38.7	47.4	61.2	86.5	106			
	SS18	41.1	34.3	41.1	58.1	71.1	91.8	130	159			
1	SS25	57.0	47.7	57.0	80.6	98.8	127	180	221	26.5	42.2	142
	SS35	79.8	66.8	79.8	113	138	178	252	309			
1 1/4	SS50	114	95.4	114	161	198	255	361	442	31.0	53.1	227
	SS70	160	134	160	226	277	357	505	618			

$$\text{Flow Rate (l/min)} = K\sqrt{\text{bar}}$$

Standard Materials: Brass, 303, and 316 Stainless Steel.



MISTING

CALL 413-772-0846  
 Call for the name of your nearest BETE representative.

# XA

## Low Flow Air Atomizing

The XA nozzle system uses the energy in compressed air to produce highly atomized sprays at low flow rates. There are many interchangeable components that can be assembled to achieve a variety of spraying objectives.

### SPRAY SET-UPS

XA nozzles produce eight distinctly different types of sprays, depending on which interchangeable air and fluid caps are selected. The spray type and flow rate are determined by the "set-up" — a specific combination of one air cap and one fluid cap.

#### Internal Mix Set-ups

Liquid and air streams meet within the nozzle and are mixed together and expelled through the same orifice(s). This internal mixing means the streams are not independent; a change in air flow will affect the liquid flow. This makes precise metering of the liquid more difficult than with an External Mix Set-up. Internal Mix Set-ups are able to produce the finest atomization of any of the XA set-ups, but they are generally not suitable for use with liquids which have a viscosity that is above 200 centipoise.

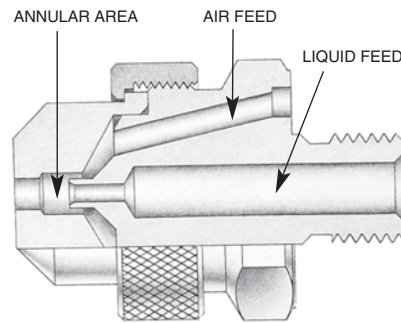

Cutaway View: Internal Mix Set-up

#### External Mix Set-ups

The air and liquid streams exit the nozzle independently and are combined and mixed outside of the nozzle. Because there is no connection between the air and liquid lines within the nozzle, the air and liquid flow rates can be controlled independently, allowing precise metering of the liquid. The atomization can be controlled by adjusting the air flow rate — more air produces finer atomization. In most

cases these set-ups do not atomize as finely as Internal Mix Set-ups.

External Mix Set-ups may be used with liquids having a viscosity above 200 centipoise and for abrasive suspensions. BETE Applications Engineers can provide guidance for

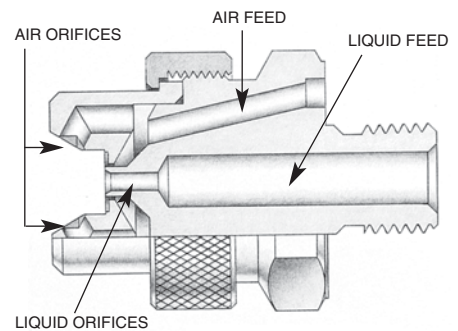

Cutaway View: External Mix Set-up

spraying high viscosity liquids.

#### Siphon Set-ups

Internal and External Mix Set-ups require the liquid to be supplied to the nozzle under pressure from a municipal water supply, pump, or pressure pot. Siphon Set-ups use the flow of compressed air within the nozzle to siphon liquid from a container. Siphon Set-ups are frequently used for spraying additives from a container without the use of a pump. They provide the

AIR ATOMIZING

TO ORDER: specify pipe size, body style, spray set-up #, hardware and mounting assemblies, and material. See page 78.

E. Air Operated Shut-off

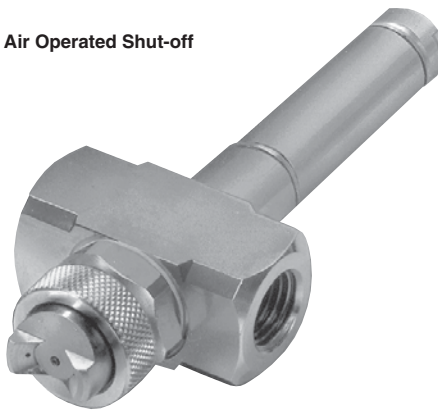

A. End Plug



D. Clean-out/Shut-off



B. Shut-off

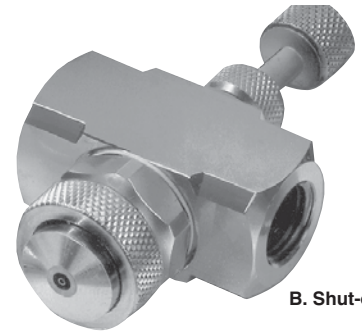

Bold letters (A, B, C, D, E, F) refer to hardware assemblies shown on p. 78.

# XA Components & Options

lowest flow rates available in the XA series (as low as 0.38 L/hr). They are generally not suitable for use with liquids having a viscosity above 200 centipoise.

By supplying the liquid under pressure, SR Set-ups may be used with liquids having a viscosity above 200 centipoise. In this case, the liquid flow rate is regulated by the fluid cap, and can be determined by using the EF chart for the specific fluid cap.

## BASIC OPERATION

The basic XA nozzle assembly consists of a body, a spray set-up, and a "hardware assembly" that can provide shut-off and clean-out capabilities.

### Non-Automatic Operation

The XA00 Square Body is the basic component of a non-automatic XA nozzle. Air and liquid feeds are located at opposite ends, perpendicular to the spray.

The XA03 Body has air and liquid feeds on one side, perpendicular to the spray axis.

The XA05 Body has air and liquid inlets located in-line with the spray. Hardware assemblies cannot be used with the XA05 body.

## Hardware Assemblies for Non-Automatic Operation

**A. Plug.** The minimum option hardware assembly required for XA operation. Provides neither clean-out nor shut-off.

**B. Shut-off.** Turning the knurled knob will stop the flow of liquid to the nozzle. Should not be used to meter the flow of liquid.

**C. Clean-out.** Pressing the spring-loaded plunger will force a small diameter rod through the liquid orifice, cleaning any obstruction. Useful for intermittent spraying of a liquid that may dry in the orifice when not in use.

**D. Clean-out/Shut-off.** Combines functions of hardware assemblies B and C in one unit.



PR Air Cap



Fluid Cap



FF Air Cap



SR Air Cap



ER Air Cap



EF Air Cap



XW Air Cap



PF Air Cap

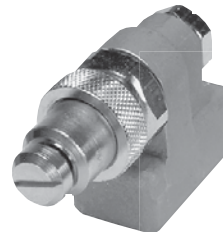

XA03 Body

XA00 Body with C Hardware



XA05 Body

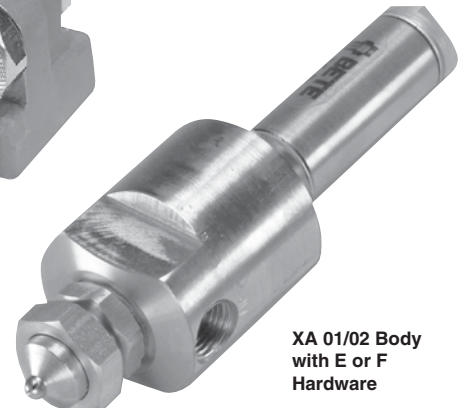

XA 01/02 Body with E or F Hardware



# XA Components & Options

## Spray Set-up

## Body Styles and Seals

## Hardware Assemblies

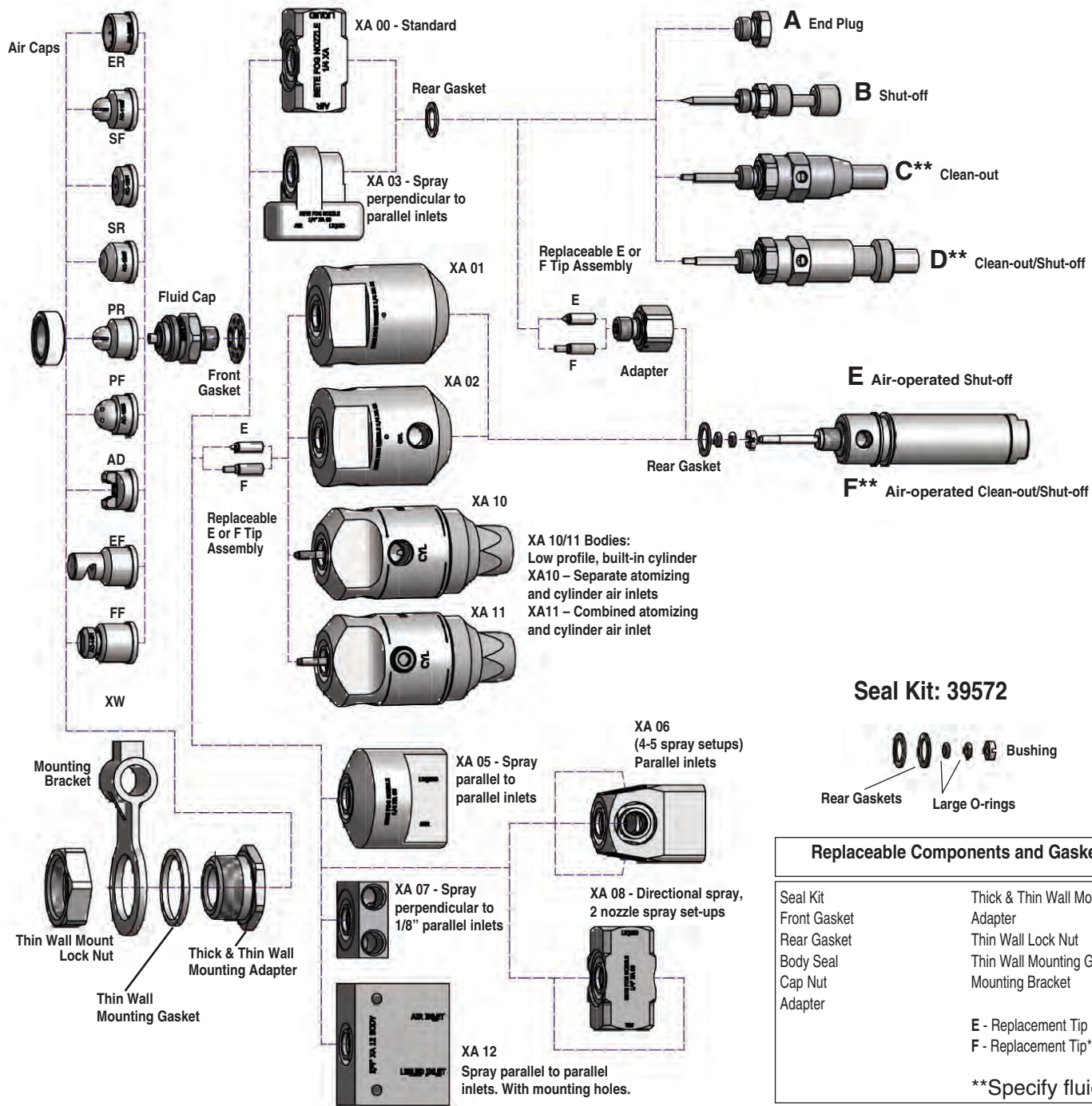

Replaceable Components and Gaskets	
Seal Kit	Thin & Thin Wall Mount
Front Gasket	Adapter
Rear Gasket	Thin Wall Lock Nut
Body Seal	Thin Wall Mounting Gasket
Cap Nut	Mounting Bracket
Adapter	
	E - Replacement Tip
	F - Replacement Tip**
	**Specify fluid cap

### TO ORDER

### Spray Set-up Number

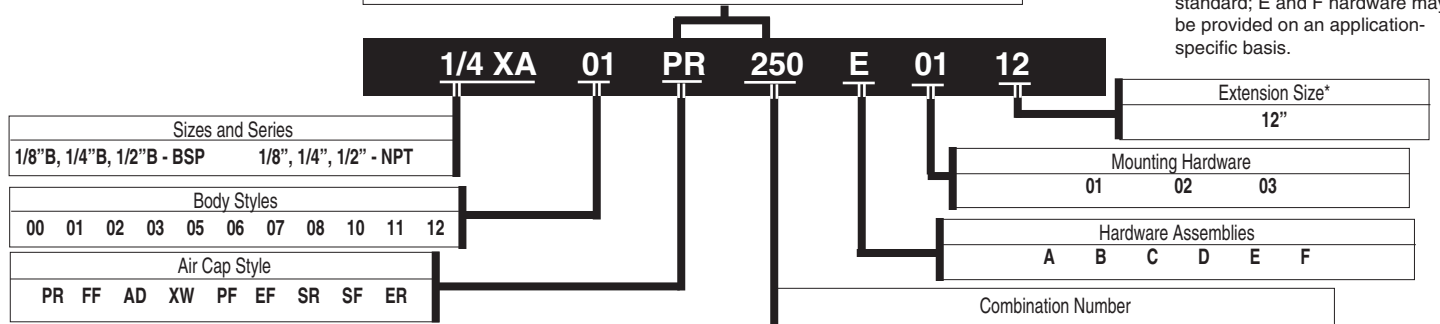

\*For extensions, A hardware is standard; E and F hardware may be provided on an application-specific basis.

AIR ATOMIZING

TO ORDER: specify pipe size, body style, spray set-up #, hardware and mounting assemblies, and material. See page 78.

# XA Components & Options

## AUTOMATIC OPERATION

For critical applications which require automatic, no-drip, or high-speed spray shut-off, the XA can be supplied with an air-cylinder-operated shut-off or clean-out/shut-off. These air cylinders provide virtually instantaneous liquid shut-off at rates of up to 180 cycles per minute. *The air cylinders require a minimum of 5.5 bar to run that fast.*

### Bodies for Automatic Operation

The XA01, XA02, XA10, and XA11 Round Bodies are rugged, highly reliable, and well-suited to the rigors of high-cycle automatic operation. They have been designed to simplify the feed piping required for installing automatic nozzles by providing a constant location for the air inlet piping. With their neat, professional appearance, they are particularly recommended for OEM applications.

The XA01 Round Body has one inlet for air and one for liquid. Because the air inlet supplies air for both cylinder movement and liquid atomization, spraying during start-up and shut-off is not as crisp and precise as with the XA02. *The XA01 body cannot be used with atomizing air pressure under 2 bar.*

The XA02 Round Body has two inlets for air and one inlet for liquid. One of the air inlets supplies the cylinder and the other supplies

atomizing air. The XA02 body must be used when the air cylinder operates at a different pressure from the atomizing air or where the atomizing air is supplied below 2 bar. *NOTE: The XA00 Square and XA03 Bodies used for non-automatic operation can also be used, with hardware assemblies E or F, for automatic operation. Special design features allow field upgrading to automatic operation.*

The XA10 and XA11 Bodies have a built in air-operated cylinder. The integral cylinder provides a smaller profile for use where space is limited.

### Hardware Assemblies for Automatic Operation

**E. Air-Operated Shut-off.** Removal of air pressure to the cylinder causes a spring-loaded poppet valve actuator to shut off liquid flow.

**F. Air-Operated Clean-out/Shut-off.** Operation similar to E, but includes a clean-out needle.

## SOLENOID VALVES

Electrically operated solenoid valves can be used to control the operation of any XA nozzle. BETE can supply solenoid valves matched to your specific application.

### Solenoids for Automatic XA Nozzles.

A 3-way, quick-exhaust solenoid valve is required to operate the E or F hardware assembly. The valve is

located in the line that supplies air to the cylinder, as close to the nozzle as possible. Independent control of the atomizing air of an XA02 or square body requires an additional 2-way solenoid valve.

### Solenoids for Non-Automatic XA Nozzles.

Two-way solenoid valves can be used to stop and start the flow of air and liquid to any non-automatic XA nozzle.

## FILTERS, REGULATORS AND STRAINERS

For optimum reliability, every XA nozzle should have a strainer and regulator in the liquid feed line and a filter and regulator in the air feed line. Every XA nozzle with a Siphon Feed Set-up should have a filter and regulator in the air line. The size and type of each of these components depends on the application, and can be determined by your BETE sales representative. BETE maintains an inventory of filters, strainers, and regulators that can be supplied with your XA nozzle to ensure reliable operation. These components can be purchased individually or in kit form.



Simple piping and robust design describe this multiple nozzle XA lance.



The XA06 manifold body can be fitted with up to five nozzle setups and is often used for humidification of large areas.



Corrosion-resistant XA in PVC



# XA Components & Options

## SPRAY EXTENSIONS

The spray set-up can be moved away from the nozzle body by using optional 152mm or 305mm extensions. These allow the spray to be moved closer to the target while keeping the nozzle body and associated piping at a distance.

## MOUNTING HARDWARE

In many XA installations the nozzle is supported by the rigid metal pipe that supplies air or liquid. There are several components which can provide support for the XA Bodies when it isn't appropriate to suspend the nozzle from piping; for example, when the nozzle will spray through the wall of a tank or duct, or when the air and liquid will be supplied through flexible tubing. All XA bodies except the XA03 can be used with any of the mounting hardware described here.

### Thin Wall 02 Adapter

Three-piece adapter used to support an XA nozzle with the body located outside a tank or duct having a relatively thin (less than 10mm) wall and the spray directed into the interior. To use this adapter, a 27mm diameter hole must be drilled through the wall. This adapter both secures the air cap and attaches the nozzle body to the tank wall.

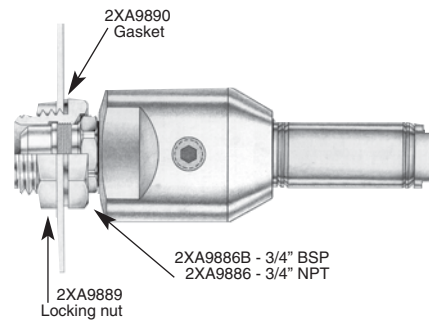

XA02 with Thin Wall 02 Adapter

### Thick Wall 01 Adapter

Similar in design and function to the Thin Wall Adapter, but intended for use with tanks or ducts with walls that are thick enough (10mm or over) to be drilled and tapped for a 3/4" NPT thread.

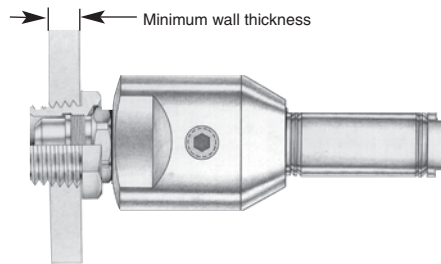

XA02 with Thick Wall 01 Adapter

### Mounting Bracket 03 Adapter

This bracket is used in combination with a Thin Wall Adapter to support an XA nozzle from a 13mm-diameter metal rod. The bracket allows flexibility in aiming the spray.

## MATERIALS

### Bodies, Fluid Caps, Air Caps, Hardware Assemblies, Mounting Hardware

The standard materials for the XA series are nickel-plated brass and 303 and 316 stainless steels. Other metals and plastics can be supplied on request. See page 12 for a complete material list.

### Air Cylinders

The air cylinders used for XA hardware assemblies E and F have rods and cylinders made of stainless steel and end caps made of anodized aluminum. All metal parts in contact with the spray liquid are 316 stainless steel.

### Seals

The standard material for XA gaskets is compressed fiber with a neoprene binder. For installations requiring FDA approval, SBR gaskets are available. Other elastomeric and metallic gasket materials can be supplied on request.

The standard material for O-rings in XA automatics is Viton®. Other materials available on request.



XA03 Mounting Bracket

**BETE can fabricate XA nozzles into any number of lance assembly variations**

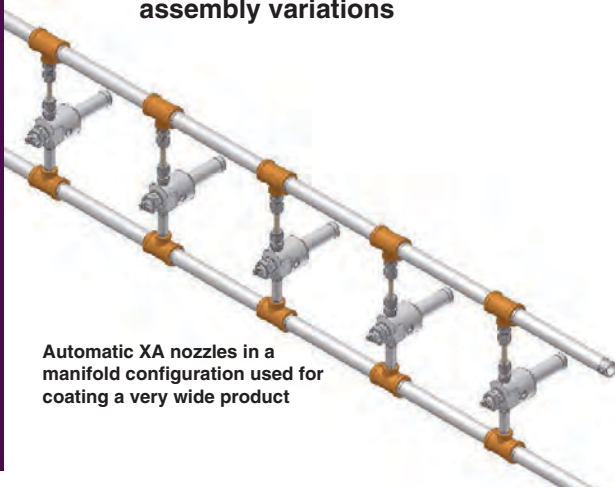

Automatic XA nozzles in a manifold configuration used for coating a very wide product

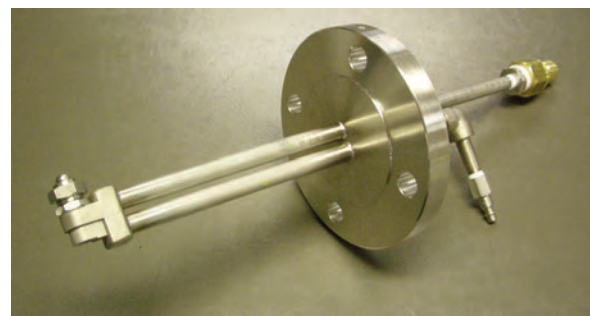

Spray lance (see pages 18, 19) with a right angle XA and quick-connect fittings

# XA Components & Options

## Spray Set-up Numbers

SPRAY SET-UP	PIPE SIZE BSP or NPT	SET-UP NO.	FLUID CAP	AIR CAP		
EF	FLAT FAN (EXTERNAL MIX)	1/8	EF 050	FC7	AC1001	
			EF 100		AC1003	
			EF 150	FC4	AC1001	
			EF 200		AC1003	
			EF 250		AC1001	
			EF 300	FC3	AC1003	
			EF 350	FC6	AC1002	
		OR	1/4	EF 400		AC1004
				EF 450	FC2	AC1002
				EF 500		AC1004
				EF 550	FC1	AC1002
				EF 600		AC1004
				EF 650	FC8	AC1005
				EF 700	FC9	AC1005
EF 750	FC5	AC1005				
	1/2	EF 5050	FC501	AC5001		
SF	SIPHON FLAT FAN	1/8	SF 050	FC3	AC1101	
			SF 100	FC6	AC1102	
		OR	1/4	SF 150	FC2	AC1103
				SF 200	FC2	AC1104
SR	SIPHON ROUND	1/8	SR 050	FC7	AC1201	
			SR 150	FC4	AC1201	
			SR 200	FC4	AC1202	
		OR	1/4	SR 250	FC3	AC1202
				SR 400	FC1	AC1204
				SR 450	FC5	AC1205
	1/2	SR 5050	FC501	AC5201		
PF	PRESSURE FLAT FAN	1/8	PF 050	FC4	AC1301	
			PF 100	FC3	AC1303	
			PF 150	FC3	AC1301	
		OR	1/4	PF 200	FC3	AC1302
				PF 250	FC2	AC1304
				PF 300	FC1	AC1304
		PF 350	FC1	AC1305		
		PF 400	FC5	AC1306		
XW	EXTRA WIDE-ANGLE ROUND	1/2	PF 5050	FC501	AC5301	
			PF 5100	FC502	AC5302	
		1/8 OR 1/4	XW 050	FC8	AC1401	
	1/2	XW 5050	FC502	AC5401		
PR	PRESSURE ROUND	1/8	PR 050	FC4	AC1501	
			PR 100	FC4	AC1502	
			PR 150	FC3	AC1502	
			PR 200	FC2	AC1503	
		OR	1/4	PR 250	FC1	AC1503
				PR 300	FC5	AC1504
				PR 5050	FC501	AC5501
				PR 5100	FC502	AC5502
AD	WIDE ANGLE ROUND	1/8	AD 050	FC4	AC1601	
			AD 100	FC2	AC1603	
			AD 150	FC2	AC1602	
			AD 200	FC1	AC1603	
			AD 250	FC1	AC1604	
		OR	1/4	AD 300	FC5	AC1605
				AD 5050	FC501	AC5601
	1/2	AD 5100	FC501	AC5602		
		AD 5150	FC501	AC5603		
		AD 5200	FC502	AC5604		
FF	DEFLECTED FLAT FAN	1/8 OR 1/4	FF 050	FC10	AC1701	
ER	NARROW ANGLE ROUND	1/8	ER 050	FC7	AC1801	
			ER 150	FC4		
			ER 250	FC3		
			ER 350	FC6	AC1802	
		OR	1/4	ER 450	FC2	
				ER 550	FC1	
				ER 650	FC3	AC1803
				ER 750	FC9	
		ER 850	FC5			

## Dimensions with Hardware Options for XA00 Body, BSP or NPT

Pipe Size	Hardware Option	Dimensions in (mm)			
		W	X	Y	Max. "Z"
1/8 OR 1/4	A				14.3
	B				42.3
	C	22.2	42.9	49.2	63.5
	D				77.0
	E				103
	F				103
1/2	A	31.8	63.5	68.3	25.4

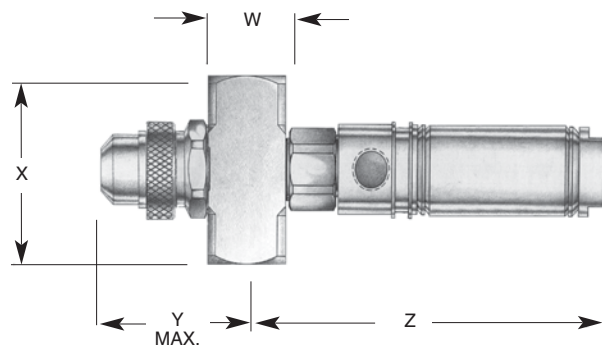

Overall Dimensions of XA Assemblies with XA00 Body (Shown with E or F Hardware)

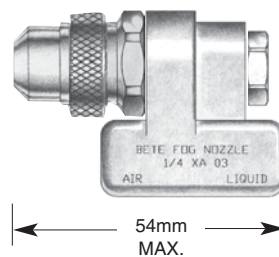
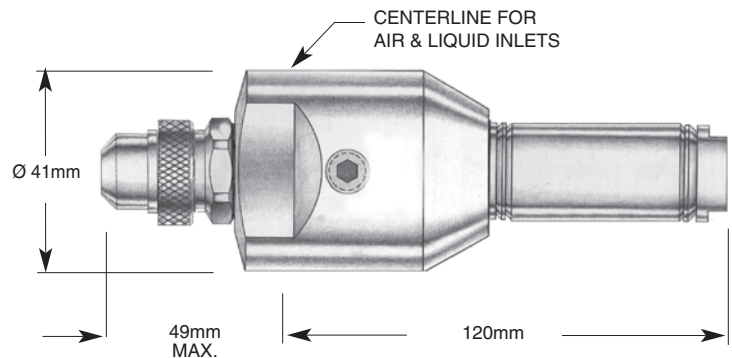

Overall Dimensions for Assemblies with XA05 Bodies

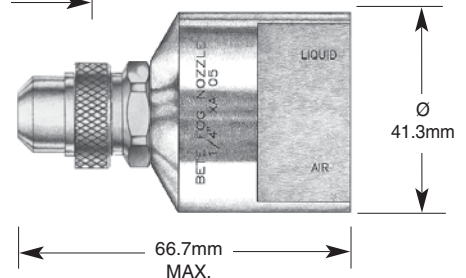

AIR ATOMIZING

CALL 413-772-0846  
Call for the name of your nearest BETE representative.



# XA Components & Options

## SYSTEM SET-UPS AND ACCESSORIES

BETE carries a complete line of controls and accessories required for setting up a system using the XA Series nozzles.

Contact your BETE representative for details.

### Pressure System Set-up

In a pressure-fed system, the liquid is supplied under pressure to either internal or external mix BETE XA Series nozzles.

Air and liquid regulators control the fluid delivery pressure, while the air filter and liquid strainer ensure that the supplied fluids are of high quality.

Operational control is maintained by manual or solenoid valves used in conjunction with the various hardware assemblies.

### Siphon System Set-up

In a siphon-fed system, the liquid is supplied by either a siphon or gravity feed.

An air regulator controls the air delivery pressure, while the air filter ensures that the compressed air is of high quality.

Operational control is maintained by manual or solenoid valves used in conjunction with the various hardware assemblies.

When used as a gravity feed set-up, a positive liquid shutoff capability should be provided.

Filters, regulators, and strainers matched to your XA application are available from stock.

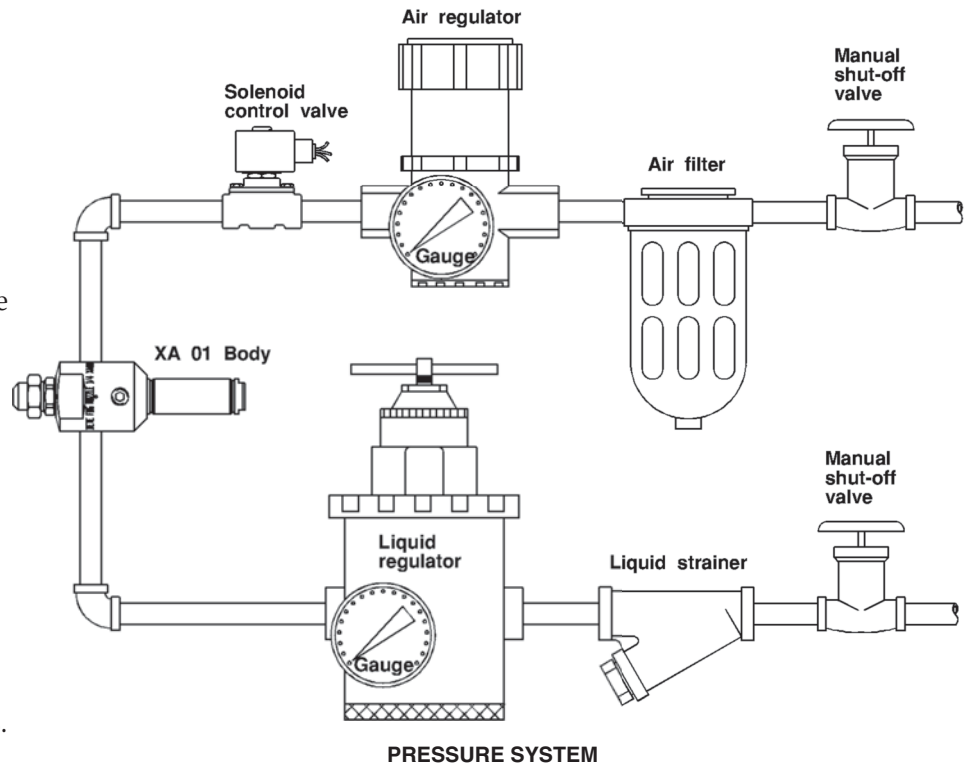

PRESSURE SYSTEM

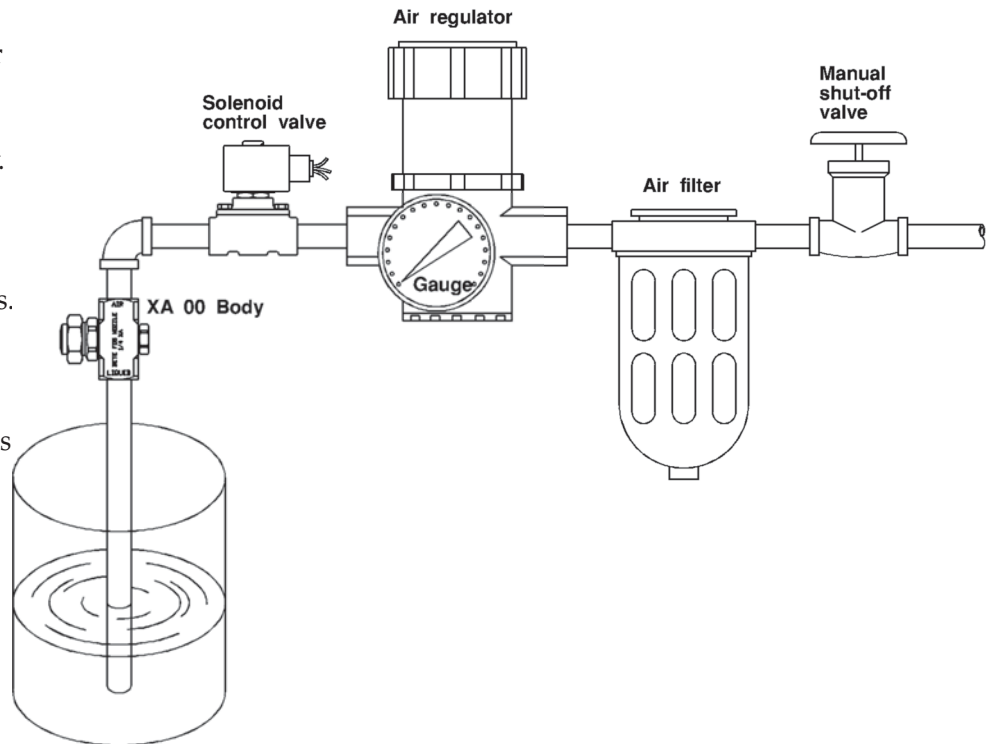

SIPHON SYSTEM

# XAAD

## Pressure-fed/Int. Mix/Wide Angle Round

### DESIGN/SPRAY CHARACTERISTICS

- Internal mix
- Very fine atomization
- 70° Hollow Cone spray pattern
- Moderate forward spray projection

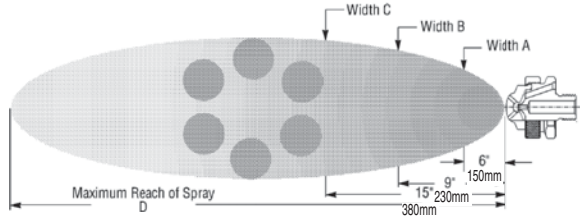

Dimensions are approximate. Check with BETE for critical dimension applications.

### XA AD Set-up Flow Rates and Dimensions

Pressure-fed, Internal Mix, Wide Angle Round Spray Pattern, 1/8" and 1/4" Pipe Sizes, BSP or NP T

Pipe Size	Spray Set-up Number	Fluid and Air Cap Numbers	0.7 Bar Liquid			1.5 Bar Liquid			2.0 Bar Liquid			3.0 Bar Liquid			4.0 Bar Liquid			Spray Dimensions						
			Air (bar)	l/h	Nm <sup>3</sup> /h	Air (bar)	l/h	Nm <sup>3</sup> /h	Air (bar)	l/h	Nm <sup>3</sup> /h	Air (bar)	l/h	Nm <sup>3</sup> /h	Air (bar)	l/h	Nm <sup>3</sup> /h	air	liquid	A (mm)	B (mm)	C (mm)	D (mm)	
1/8	AD 050	Fluid Cap FC4 & Air Cap AC1601	0.6	5.3	0.60	1.1	8.1	0.79	1.5	8.1	0.92	2.4	8.9	1.24	3.1	10.5	1.44	0.7	0.7	140	180	230	1.5	
			0.7	4.3	0.72	1.3	7.0	0.88	1.8	6.6	1.09	2.7	8.1	1.40	3.4	9.7	1.68	1.4	1.5	150	190	240	1.8	
			0.9	3.0	0.84	1.4	6.4	0.94	2.1	4.9	1.32	3.0	6.4	1.66	3.9	7.8	2.16	1.8	2.0	160	200	250	2.1	
	AD 100	Fluid Cap FC2 & Air Cap AC1603	1.0	1.7	1.02	1.5	5.5	1.01	2.4	3.2	1.68	3.2	4.9	1.92	4.2	6.1	2.52	3.0	3.0	160	200	260	2.7	
			1.7	4.5	1.16	1.7	4.5	1.16	3.4	4.2	2.13	4.6	4.4	2.82	4.6	4.4	2.82	3.9	4.0	190	230	300	4.0	
			1.8	3.5	1.30	1.8	3.5	1.30	3.5	3.4	2.33	4.9	2.8	3.24	4.9	2.8	3.24	4.9	2.8	3.24	4.9	2.8	3.24	4.9
1/4	AD 150	Fluid Cap FC2 & Air Cap AC1602	0.9	7.0	3.00	1.7	13.2	4.08	2.0	18.5	4.08	2.8	25.0	5.04	3.7	31.0	5.76							
			1.0	2.1	3.72	1.8	9.8	4.74	2.1	15.1	4.56	3.0	22.0	5.52	3.8	28.0	6.30							
			2.2	11.7	5.10	2.2	11.7	5.10	3.1	18.5	6.06	3.9	26.0	6.78	4.1	23.0	7.32	0.9	0.7	180	240	310	1.8	
	AD 200	Fluid Cap FC1 & Air Cap AC1603	3.1	12.1	7.14	3.2	15.1	7.14	3.4	12.1	7.14	4.2	20.0	7.80	4.6	13.6	9.18	2.1	2.0	190	250	330	3.2	
			3.5	9.1	7.80	3.5	9.1	7.80	3.5	9.1	7.80	4.6	13.6	9.18	4.6	13.6	9.18	3.2	3.0	200	260	340	4.1	
			3.7	6.1	8.52	3.7	6.1	8.52	3.7	6.1	8.52	4.9	6.8	11.0	4.1	4.0	190	240	280	370	5.9			
1/4	AD 250	Fluid Cap FC1 & Air Cap AC1604	1.1	12.3	2.40	2.2	16.3	3.72	2.7	21.0	4.14	4.2	19.3	6.00	5.6	22.0	7.80							
			1.3	9.9	2.70	2.5	12.1	4.26	3.0	16.3	4.68	4.6	14.6	6.78	6.0	17.6	8.52							
			1.4	7.9	3.00	2.8	8.9	4.74	3.2	12.3	5.16	4.9	10.8	7.44	6.3	14.0	9.12	1.5	0.7	150	190	230	2.7	
	AD 300	Fluid Cap FC5 & Air Cap AC1605	1.5	6.1	3.24	3.0	7.6	4.98	3.4	10.7	5.46	5.3	8.1	8.10	6.7	11.4	9.78	3.0	1.5	160	200	240	4.6	
			1.7	4.9	3.48	3.1	6.4	5.22	3.5	9.3	5.64	5.6	6.2	8.76	7.0	9.1	10.4	3.4	2.0	160	200	240	5.5	
			1.8	3.9	3.72	3.2	5.5	5.46	3.9	6.4	6.30	6.0	4.9	9.42	6.3	4.0	10.0	5.3	3.0	180	220	250	7.3	
1/4	AD 200	Fluid Cap FC1 & Air Cap AC1603	2.0	3.1	4.02	3.4	4.7	5.70	4.2	4.7	6.90	6.3	4.0	10.0	7.0	9.1	10.4	6.3	4.0	190	240	280	9.4	
			0.7	23.1	1.70	1.4	37.1	2.38	2.1	26.9	3.91	2.8	49.2	3.91	3.7	57.2	4.59							
			0.9	8.30	2.89	1.5	30.3	2.89	2.2	22.3	4.42	3.0	40.1	4.59	3.8	53.0	5.10							
	AD 250	Fluid Cap FC1 & Air Cap AC1604	1.0	3.40	3.40	1.7	18.2	3.74	2.4	11.4	5.44	3.1	32.9	5.10	4.0	44.7	5.95	0.9	0.7	190	250	360	2.1	
			1.8	11.7	4.42	2.5	7.20	5.95	3.2	28.8	5.44	4.2	34.4	6.80	4.2	34.4	6.80	1.5	1.5	200	270	370	3.2	
			3.4	20.1	6.63	3.4	20.1	6.63	3.5	15.5	7.14	4.9	7.90	10.7	4.9	7.90	10.7	2.4	2.0	200	270	370	4.1	
AD 300	Fluid Cap FC5 & Air Cap AC1605	3.5	15.5	7.14	3.5	15.5	7.14	3.7	7.60	8.33	3.7	7.60	8.33	3.7	7.60	8.33	3.9	4.0	200	280	380	5.0		
		3.7	6.3	10.0	6.3	4.0	10.0	6.3	4.0	10.0	6.3	4.0	10.0	6.3	4.0	10.0	3.9	4.0	200	280	380	6.8		
		1.3	26.1	5.27	2.1	45.0	7.14	3.1	42.4	10.0	4.2	55.6	11.8	5.6	59.8	14.7								
1/4	AD 250	Fluid Cap FC1 & Air Cap AC1604	1.5	21.2	5.95	2.4	38.6	8.16	3.2	40.1	10.7	4.9	42.0	13.8	6.0	52.4	15.6							
			1.8	13.6	7.14	2.7	30.7	9.17	3.4	35.6	11.0	5.6	28.4	15.9	6.3	46.8	16.8	2.0	0.7	200	250	330	5.5	
			2.0	9.50	7.82	3.0	23.8	10.2	3.5	33.3	11.2	6.0	20.6	17.1	6.7	39.4	17.7	3.0	1.5	200	270	340	6.4	
	AD 300	Fluid Cap FC5 & Air Cap AC1605	2.1	7.60	8.16	3.2	19.3	10.9	3.9	24.6	12.6	6.3	14.8	18.0	7.0	33.9	18.9	3.9	2.0	220	280	370	8.2	
			2.3	4.20	8.83	3.5	12.9	11.9	4.6	11.0	15.0	6.7	7.00	19.2	6.0	3.0	230	290	380	9.1				
			2.4	2.60	9.17	4.2	1.50	14.1	4.9	6.40	16.0	7.0	1.20	20.1	6.3	4.0	240	320	400	10.4				

Standard Materials: Nickel-plated Brass, 303 Stainless Steel, and 316 Stainless Steel

AIR ATOMIZING

Call for the name of your nearest BETE representative. CALL 413-772-0846

# XAPR

## Pressure-fed/Int. Mix/Narrow Angle Round

### DESIGN/SPRAY CHARACTERISTICS

- Internal mix
- Very fine atomization
- Narrow spray angle (12°- 22°)
- Full cone pattern
- Large forward projection (up to 8.5 m)

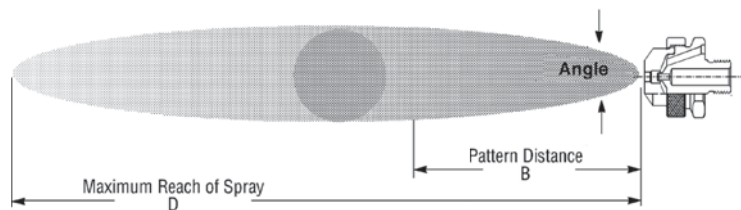

1/4" XA 02 PR050 E  
XA 02 Body; E Hardware

Dimensions are approximate. Check with BETE for critical dimension applications.

### XA PR Set-up Flow Rates and Dimensions

Pressure-fed, Internal Mix, Round Spray Pattern, 1/8" and 1/4" Pipe Sizes, BSP or NPT

Pipe Size	Spray Set-up Number	Fluid and Air Cap Numbers	0.7 Bar Liquid			1.5 Bar Liquid			2.0 Bar Liquid			3.0 Bar Liquid			4.0 Bar Liquid			Spray Dimensions							
			Air (bar)	l/h	Nm <sup>3</sup> /h	Air (bar)	l/h	Nm <sup>3</sup> /h	Air (bar)	l/h	Nm <sup>3</sup> /h	Air (bar)	l/h	Nm <sup>3</sup> /h	Air (bar)	l/h	Nm <sup>3</sup> /h	air	liquid	Spray Angle (deg.)	B (mm)	D (m)			
1/8 OR	PR 050	Fluid Cap FC4 & Air Cap AC1501	0.7	2.5	0.960	1.1	6.4	0.720	1.4	6.4	0.840	2.7	6.2	1.38	3.5	7.8	1.68								
			0.9	1.8	1.14	1.4	5.0	0.900	1.7	5.5	1.02	2.8	5.7	1.50	3.7	7.3	1.74	0.9	0.7	13	300	3			
			1.0	1.4	1.32	1.7	4.1	1.14	2.0	4.5	1.20	3.0	5.2	1.62	3.9	6.4	1.98	1.7	1.5	13	330	3			
						1.8	3.4	1.20	2.2	3.4	1.44	3.1	4.7	1.74	4.2	5.5	2.28	2.5	2.0	13	360	3			
						2.0	3.0	1.38	2.4	3.0	1.56	3.2	4.3	1.86	4.5	4.5	2.58	3.1	3.0	14	390	4			
						2.1	2.6	1.50	2.5	2.5	1.68	3.4	3.9	1.98	4.6	4.1	2.70	4.5	4.0	15	440	4			
				2.2	2.0	1.62	2.7	2.3	1.86	3.7	3.0	2.28	4.8	3.7	2.82										
		PR 100	Fluid Cap FC4 & Air Cap AC1502	0.7	2.5	1.14	1.4	5.7	1.62	1.7	6.7	1.74	2.2	9.2	2.04	2.8	11.9	2.34							
	0.9			2.0	1.32	1.5	5.2	1.74	1.8	6.4	1.86	2.5	8.2	2.34	3.1	11.0	2.58	0.9	0.7	12	430	4			
	1.0			1.6	1.56	1.7	4.8	1.92	2.0	5.9	2.04	2.8	7.2	2.64	3.4	10.1	2.82	1.5	1.5	13	460	4			
						1.8	4.3	2.10	2.1	5.2	2.22	3.0	6.7	2.82	3.7	9.2	3.12	2.4	2.0	13	480	4			
						2.0	3.9	2.22	2.2	4.8	2.40	3.1	6.3	2.94	3.9	8.4	3.48	3.0	3.0	13	510	5			
					2.1	3.4	2.40	2.4	4.3	2.58	3.2	5.9	3.12	4.2	7.6	3.72	3.9	4.0	15	560	5				
1/4	PR 150	Fluid Cap FC3 & Air Cap AC1502	0.9	4.8	1.26	1.7	8.4	1.86	2.0	10.7	1.98	2.7	16.5	2.22	3.4	20.0	2.58								
			1.1	4.1	1.62	1.8	7.5	2.10	2.1	9.8	2.22	2.8	15.4	2.28	3.7	18.4	2.82	1.5	0.7	12	480	4			
			1.4	3.4	1.98	2.0	7.0	2.22	2.4	8.2	2.52	3.1	13.6	2.58	3.9	16.8	3.00	2.5	1.5	13	510	4			
			1.5	3.1	2.10	2.2	5.7	2.64	2.7	6.8	2.88	3.4	11.8	2.94	4.2	15.2	3.30	3.0	2.0	13	530	5			
			1.7	3.0	2.34	2.5	4.8	2.94	3.0	5.9	3.30	3.7	10.4	3.30	4.5	13.8	3.60	3.4	3.0	14	560	5			
			1.8	2.9	2.46	2.8	4.1	3.24	3.2	5.0	3.54	3.9	9.1	3.66	4.8	12.4	3.90	4.2	4.0	15	600	5			
		PR 200	Fluid Cap FC2 & Air Cap AC1503	2.0	2.8	2.64	3.1	3.6	3.54	3.5	4.1	3.90	4.2	7.9	3.90	4.9	11.8	4.08							
	1.1			13.0	4.56	2.2	17.8	6.96	2.8	20.0	8.16	3.4	32.0	8.94	4.6	37.0	11.6								
	1.4			8.9	5.46	2.5	13.1	7.80	3.1	16.3	8.94	3.9	25.0	10.2	5.3	29.0	13.2	1.7	0.7	18	660	5			
	1.5			7.2	5.88	2.8	9.5	8.58	3.4	11.9	9.78	4.6	15.9	12.3	5.6	25.0	14.1	2.8	1.5	20	760	6			
	1.7			5.8	6.30	3.1	7.0	9.42	3.9	7.0	11.2	5.3	9.1	14.4	6.0	21.0	15.0	3.9	2.0	20	810	7			
	1.8			4.7	6.72	3.4	4.9	10.3	4.2	4.7	12.3	5.6	6.8	15.3	6.3	17.4	16.2	5.3	3.0	21	910	8			
	PR 250	Fluid Cap FC1 & Air Cap AC1503	2.0	3.6	7.14	3.5	4.2	10.7	4.6	3.0	13.2	6.0	5.0	16.5	6.7	14.0	17.4								
2.1			2.7	7.62								6.3	3.6	17.4	7.0	11.0	18.3								
0.9			31.0	3.42	1.4	61.0	4.14	2.1	53.0	5.76	2.7	80.0	6.18	3.8	88.0	8.10									
1.0			25.0	3.96	1.5	54.0	4.56	2.4	41.0	6.72	3.0	69.0	7.02	4.2	73.0	9.36	1.0	0.7	17	610	5				
1.1			18.5	4.50	1.7	48.0	5.10	2.7	31.0	7.62	3.2	59.0	7.80	4.6	61.0	10.6	1.8	1.5	18	690	6				
1.3			12.9	5.10	1.8	41.0	5.58	2.8	26.0	8.16	3.5	49.0	8.76	4.9	48.0	11.8	2.8	2.0	20	760	7				
	PR 300	Fluid Cap FC5 & Air Cap AC1504	2.0	2.0	35.0	6.12	3.0	22.0	8.64	3.7	44.0	9.24	5.3	39.0	12.9	3.5	3.0	20	790	7					
					2.1	30.0	6.60				3.8	37.0	9.66	5.6	31.0	14.4	4.9	4.0	21	910	9				
					2.2	25.0	7.14				3.9	35.0	10.2	6.0	23.0	15.6									
1.0			44.0	5.16	1.4	125	4.74	2.0	123	6.48	2.2	199	5.28	3.0	250	5.94									
1.1			32.0	6.12	1.5	106	5.46	2.1	108	7.14	2.5	174	6.60	3.2	225	7.20	1.0	0.7	19	890	6				
					1.7	87.0	6.30	2.2	95.0	7.80	2.8	146	7.98	3.5	205	8.46	1.7	1.5	20	990	7				

Standard Materials: Nickel-plated Brass, 303 Stainless Steel, and 316 Stainless Steel

# XAPF

## Pressure-fed/Internal Mix/Flat Fan

### DESIGN/SPRAY CHARACTERISTICS

- Internal mix
- Flat fan, wide angle spray patterns (between 80° and 90°)
- Very fine atomization

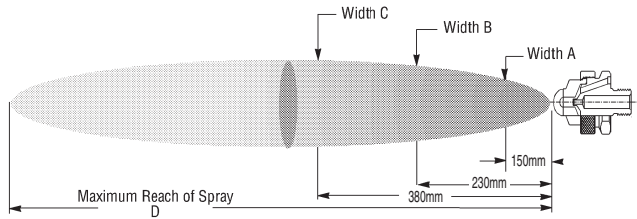

Dimensions are approximate. Check with BETE for critical dimension applications.

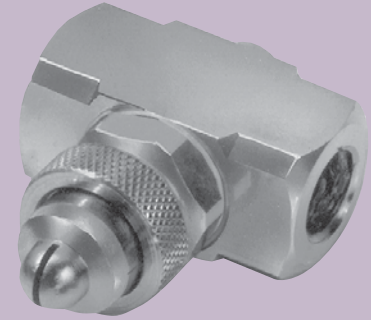

1/4" XA PF300 A  
XA 00 Body; A Hardware

### XA PF Set-up Flow Rates and Dimensions

Pressure-fed, Internal Mix, Flat Spray Pattern, 1/8" and 1/4" Pipe Sizes, BSP or NPT

Pipe Size	Spray Set-up Number	Fluid and Air Cap Numbers	0.7 Bar Liquid			1.5 Bar Liquid			2.0 Bar Liquid			3.0 Bar Liquid			4.0 Bar Liquid			Spray Dimensions					
			Air (bar)	l/h	Nm <sup>3</sup> /h	Air (bar)	l/h	Nm <sup>3</sup> /h	Air (bar)	l/h	Nm <sup>3</sup> /h	Air (bar)	l/h	Nm <sup>3</sup> /h	Air (bar)	l/h	Nm <sup>3</sup> /h	air	liquid	A (mm)	B (mm)	C (mm)	D (m)
1/8 OR 1/4	PF 050	Fluid Cap FC4 & Air Cap AC1301	0.7	5.5	1.44	1.3	9.1	1.86	2.0	8.6	2.52	2.7	11.2	3.12	3.9	12.0	4.14	1.1	0.7	250	360	460	2.6
			0.9	4.7	1.62	1.5	7.7	2.16	2.2	7.5	2.82	3.0	10.1	3.36	4.6	9.7	4.86	2.1	1.5	360	480	660	3.0
			1.0	4.1	1.86	1.8	6.5	2.52	2.5	6.2	3.12	3.2	9.1	3.72	5.3	7.5	5.58	2.8	2.0	380	530	760	3.2
			1.1	3.5	2.04	2.1	5.4	2.82	2.8	5.2	3.42	3.5	8.1	3.96	6.0	5.3	6.24	3.5	3.0	470	610	860	3.4
			1.3	3.0	2.22	2.4	4.3	3.12	3.1	4.2	3.78	4.2	5.4	4.74	6.3	4.3	6.60	6.0	4.0	560	740	940	4.0
	PF 100	Fluid Cap FC3 & Air Cap AC1303	1.3	3.0	1.80	2.1	7.4	2.40	3.0	6.1	3.12	3.9	9.4	3.60	5.3	10.2	4.68	1.5	0.7	250	330	460	1.8
			1.4	3.0	1.98	2.4	5.3	2.70	3.1	5.3	3.24	4.2	7.2	4.02	5.6	8.3	5.04	2.7	1.5	360	510	690	2.0
			1.5	2.3	2.10	2.5	4.4	2.82	3.2	4.5	3.42	4.6	5.3	4.38	6.0	6.6	5.34	3.2	2.0	480	580	740	2.0
			1.7	1.8	2.28	2.7	3.7	3.00	3.4	3.8	3.54	4.9	3.8	4.80	6.3	5.1	5.88	4.2	3.0	610	740	940	2.1
			1.8	1.3	2.46	2.8	3.1	3.12	3.5	3.2	3.72							5.6	4.0	640	760	970	2.3
	PF 150	Fluid Cap FC3 & Air Cap AC1301	0.9	8.2	1.20	1.4	14.4	1.62	2.1	13.5	2.16	2.7	19.1	2.52	4.6	16.1	4.14	1.1	0.7	360	460	710	2.1
			1.0	6.8	1.38	1.7	11.9	1.92	2.4	11.4	2.52	3.0	17.1	2.76	4.9	13.8	4.56	2.1	1.5	430	610	810	2.4
1.1			5.5	1.62	2.0	9.5	2.22	2.7	9.2	2.82	3.2	15.1	3.12	5.3	11.5	4.98	3.0	2.0	510	660	890	2.6	
1.3			4.1	1.80	2.1	8.3	2.40	3.0	7.1	3.18	3.5	13.1	3.42	5.6	9.3	5.40	3.5	3.0	580	760	970	2.7	
1.4			2.9	2.04	2.2	7.1	2.58	3.2	5.0	3.54	4.2	8.1	4.32	6.0	7.3	5.82	5.6	4.0	580	760	970	3.2	
PF 200	Fluid Cap FC3 & Air Cap AC1302	1.0	9.0	1.50	2.0	10.4	2.46	2.4	11.6	2.88	3.1	15.6	3.36	4.2	17.1	4.38	1.4	0.7	100	130	170	3.0	
		1.1	7.8	1.80	2.1	9.3	2.70	2.5	10.4	3.06	3.2	14.6	3.54	4.6	15.0	4.80	2.5	1.5	130	150	200	3.7	
		1.3	6.6	1.92	2.2	8.2	2.88	2.7	9.4	3.24	3.4	13.7	3.72	4.9	12.8	5.22	3.2	2.0	130	170	220	4.0	
		1.4	5.2	2.16	2.5	6.1	3.30	3.0	7.3	3.66	3.8	10.8	4.26	5.3	11.0	5.64	3.8	3.0	150	220	280	4.2	
		1.7	3.1	2.64	2.8	4.3	3.72	3.2	5.5	4.08	4.2	8.5	4.92	5.6	9.4	6.18	5.3	4.0	200	250	330	4.8	
PF 250	Fluid Cap FC2 & Air Cap AC1304	1.1	11.2	3.24	2.1	18.0	4.74	2.7	19.6	5.58	3.5	27.0	6.72	4.6	33.0	8.22	1.4	0.7	150	180	200	3.0	
		1.3	8.5	3.60	2.2	15.8	5.04	2.8	17.3	5.88	3.7	25.0	6.96	4.9	28.0	8.94	2.4	1.5	230	280	330	3.2	
		1.4	6.5	3.90	2.4	13.6	5.34	3.0	15.2	6.18	3.8	23.0	7.26	5.3	24.0	9.66	3.0	2.0	250	330	400	3.4	
		1.5	5.0	4.26	2.5	11.6	5.70	3.1	13.2	6.54	3.9	21.0	7.56	5.6	19.7	10.4	3.7	3.0	300	380	460	3.5	
		1.7	3.8	4.62														5.3	4.0	330	410	480	4.0
PF 300	Fluid Cap FC1 & Air Cap AC1304	0.9	27.0	1.98	1.8	38.0	3.30	2.4	39.0	4.02	3.2	58.0	4.56	4.6	59.0	6.36	1.1	0.7	180	230	300	3.4	
		1.0	20.0	2.28	2.1	28.0	3.96	2.7	30.0	4.62	3.5	47.0	5.22	5.3	40.0	7.92	2.4	1.5	230	300	410	3.5	
		1.1	15.9	2.70	2.2	24.0	4.26	3.0	24.0	5.22	3.8	38.0	5.82	5.6	32.0	8.70	3.2	2.0	250	330	430	3.7	
		1.3	12.5	2.88	2.4	21.0	4.56	3.2	17.8	5.88	3.9	34.0	6.18	6.0	26.0	9.48	3.9	3.0	300	380	480	3.8	
		1.4	10.2	3.36	2.5	17.8	4.92	3.4	15.1	6.18	4.2	27.0	6.78	6.3	20.0	10.3	3.2	4.0	330	410	510	4.4	
PF 350	Fluid Cap FC1 & Air Cap AC1305	1.0	17.0	1.38	2.0	24.0	2.64	2.4	28.0	3.06	3.4	38.0	4.32	3.9	65.0	4.50	1.1	0.7	100	130	150	2.4	
		1.1	11.0	1.62	2.1	18.9	3.00	2.5	23.0	3.54	3.5	33.0	4.80	4.2	53.0	5.34	2.1	1.5	100	130	170	3.0	
		1.3	7.6	1.98	2.2	14.4	3.36	2.7	18.9	3.96	3.7	28.0	5.34	4.6	40.0	6.48	2.8	2.0	130	170	220	3.4	
		1.4	3.2	2.40	2.4	10.6	3.78	2.8	15.1	4.44	3.8	23.0	5.82	4.9	30.0	7.62	3.7	3.0	150	200	280	3.6	
					2.5	7.2	4.26	3.0	11.7	4.74	4.2	13.1	7.20	5.6	13.8	10.4	4.9	4.0	200	250	350	4.0	
PF 400	Fluid Cap FC5 & Air Cap AC1306	1.0	29.0	5.40	1.8	56.0	7.02	2.1	100	7.14	3.0	126	8.40	4.1	140	10.9	1.0	0.7	180	200	250	3.4	
		1.1	18.9	6.48	2.0	40.0	7.98	2.2	79.0	7.98	3.1	110	9.06	4.2	125	11.6	1.8	1.5	250	300	430	3.8	
																		2.4	2.0	250	300	460	4.3
																		3.4	3.0	330	410	530	4.6
																		4.9	4.0	360	430	580	5.2

Standard Materials: Nickel-plated Brass, 303 Stainless Steel, and 316 Stainless Steel



# XASR

## Siphon-fed Round

### DESIGN FEATURES

- Lowest flow available
- Very fine atomization
- Narrow spray angle (12°- 22°)
- Full cone pattern
- Short to moderate forward spray projection

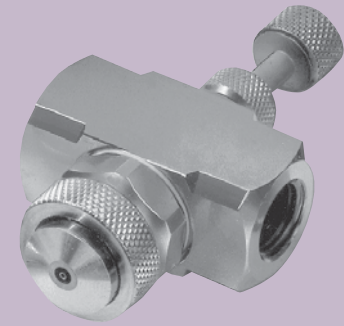
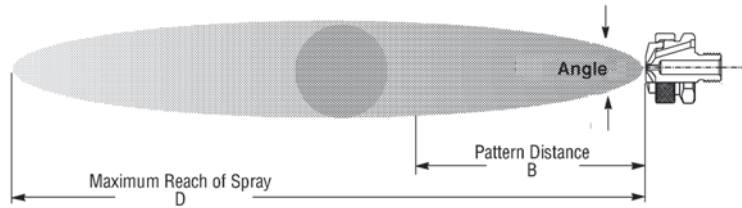

1/4"XA SR 200 B  
XA 00 Body; B Hardware

Dimensions are approximate. Check with BETE for critical dimension applications.

### XA SR Set-up Flow Rates and Dimensions

Siphon-fed, External Mix, Round Spray Pattern, 1/8" and 1/4" Pipe Sizes, BSP or NPT

Pipe Size	Spray Set-up Number	Fluid and Air Cap Numbers	ATOMIZING AIR		Liquid Capacity in l/h (Liters Per Hour)								Spray Dimensions at 200 mm. Siphon Height				
			Air (bar)	Air Capacity (Nm <sup>3</sup> /h)	Gravity Head			Siphon Height					Air (bar)	Spray Angle (deg.)	B (mm)	D (m)	
					450 mm	300 mm	150 mm	100 mm	200 mm	300 mm	600 mm	900 mm					
1/8 or 1/4	SR 050	Fluid Cap FC7 & Air Cap AC 1201	0.7	0.66	1.5	1.3	1.1	0.9	0.7	0.5				0.7	18	280	1.8
			1.5	1.02	1.8	1.7	1.5	1.3	1.2	1.1	0.6			1.5	18	280	1.9
			3.0	1.68	2.1	1.9	1.7	1.5	1.4	1.3	1.1	0.8		3.0	18	300	2.3
				4.0	2.16	2.2	2.0	1.8	1.6	1.5	1.4	1.2	0.9	4.0	18	360	2.6
		SR 150	Fluid Cap FC4 & Air Cap AC1201	0.7	0.78	2.4	2.1	1.7	1.5	1.2	0.8			0.7	18	300	2.1
	1.5			1.20	2.8	2.6	2.4	2.1	1.9	1.6	0.9			1.5	18	330	2.3
3.0	1.92			3.4	3.1	2.9	2.8	2.6	2.4	1.7	1.1		3.0	18	380	2.6	
			4.0	2.46	3.7	3.4	3.3	3.1	2.9	2.7	2.1	1.5	4.0	19	430	3.0	
	SR 200	Fluid Cap FC4 & Air Cap AC1202	0.7	1.38	2.5	2.3	2.0	1.6	1.4	1.1			0.7	18	300	2.4	
1.5			2.16	2.9	2.8	2.5	2.2	2.0	1.7	0.9			1.5	18	330	2.7	
3.0			3.48	3.4	3.3	3.2	2.9	2.8	2.5	1.9	1.2		3.0	19	380	3.4	
			4.0	4.44	3.7	3.6	3.5	3.4	3.3	3.0	2.5	2.0	4.0	20	430	4.0	
	SR 250	Fluid Cap FC3 & Air Cap AC1202	0.7	1.14	4.5	4.0	3.4	21	1.8	1.4			0.7	21	380	3.0	
1.5			1.86	5.3	4.9	4.4	3.5	2.9	2.7	1.8			1.5	21	410	3.4	
3.0			3.00	6.0	5.6	5.0	4.4	4.0	3.4	2.4	1.2		3.0	21	460	4.0	
			4.0	3.90	5.7	5.4	5.0	4.2	3.9	3.5	2.8	1.9	4.0	22	510	4.6	
	SR 400	Fluid Cap FC1 & Air Cap AC 1204	1.5	3.48	22	19.9	16.3	12.3	10.5	8.3	2.8		1.5	17	460	3.7	
3.0			5.28	25	23	19.5	16.7	14.2	11.5	6.4	2.8		3.0	18	510	4.3	
4.0			6.66	26	24	21	18.4	15.7	12.9	7.9	4.5	2.8		4.0	18	530	4.9
			5.6	8.82	26	24	22	19.7	17	14.6	9.8	6.1	5.6	19	580	5.5	
	SR 450	Fluid Cap FC5 & Air Cap AC 1205	2.0	8.64				27	22	16.8			2.0	20	510	6.7	
3.0			11.4				30	26	21				3.0	20	530	7.0	
4.0			14.4		43	40	31	28	23				4.0	21	580	7.6	
			5.6	18.9	44	42	39	31	28	24	11.0	8.3	5.6	22	630	8.2	

Standard Materials: Nickel-plated Brass, 303 Stainless Steel, and 316 Stainless Steel

# XA SF

## Siphon-fed Flat Fan

### DESIGN/SPRAY CHARACTERISTICS

- Lowest flow available
- Very fine atomization
- Flat fan spray pattern
- Moderate spray angle (60° - 85°)
- Small forward projection
- Siphon-fed

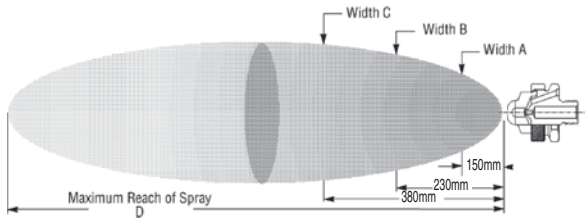

1/4"XA02 SF 050 F  
XA 02 Body; F Hardware

Dimensions are approximate. Check with BETE for critical dimension applications.

### XA SF Set-up Flow Rates and Dimensions

Siphon-fed, Internal Mix, Flat Fan Spray Pattern, 1/8" and 1/4" Pipe Sizes, BSP or NPT

Pipe Size	Spray Set-up Number	Fluid Cap and Air Cap Numbers	ATOMIZING AIR		Liquid Capacity in l/h (Liters Per Hour)								Spray Dimensions at 200 mm Siphon Height				
			Air (bar)	Air Capacity (Nm <sup>3</sup> /h)	Gravity Head			Siphon Height					Air (bar)	A (mm)	B (mm)	C (mm)	D (m)
					450 mm	300 mm	150 mm	100 mm	200 mm	300 mm	600 mm	900 mm					
1/8	SF 050	Fluid Cap FC3 & Air Cap AC1101	0.7	1.68	1.3	1.2	1.1	1.0	1.0	0.8	0.6	0.5	0.7	200	260	380	2.1
			1.5	2.58	1.2	1.1	1.0	0.9	0.9	0.8	0.7	0.5	1.5	210	290	380	2.1
			2.0	3.00	0.8	0.8	0.7	0.6	0.5					2.0	230	300	380
or	SF 100	Fluid Cap FC6 & Air Cap AC1102	1.5	3.36	3.7	3.5	3.3	2.9	2.8	2.5	2.3	2.1	1.5	230	320	380	2.7
			2.0	3.90	3.4	3.3	3.1	2.8	2.7	2.6	2.4	2.2	2.0	240	340	420	2.7
			3.0	5.22	2.8	2.7	2.5	2.4	2.2	2.1	1.9	1.7	3.0	270	370	460	3.0
1/4	SF 150	Fluid Cap FC2 & Air Cap AC1103	1.5	4.08	5.1	4.8	4.5	3.8	3.7	3.5	3.0	2.4	1.5	190	230	270	3.4
			2.0	4.68	4.9	4.7	4.4	3.6	3.4	3.2	2.9	2.3	2.0	200	250	280	3.4
			3.0	6.18	3.4	3.2	3.0	2.2	2.0	1.7				3.0	220	270	300
	SF 200	Fluid Cap FC2 & Air Cap AC1104	1.5	3.78	7.6	7.2	6.6	5.7	5.4	5.1	4.6	3.7	1.5	170	220	270	3.4
			2.0	4.38	7.6	7.3	6.8	5.9	5.7	5.5	5.0	4.2	2.0	180	230	290	3.4
			3.0	5.76	6.4	6.1	5.7	5.0	4.5	4.1	3.3			3.0	200	270	330
			3.5	6.60	4.2	3.7	3.2	2.6									

Standard Materials: Nickel-plated Brass, 303 Stainless Steel, and 316 Stainless Steel

AIR ATOMIZING

CALL 413-772-0846  
Call for the name of your nearest BETE representative.

# XAEF

## Pressure-fed/External Mix/Flat Fan

### DESIGN FEATURES

- External mix: allows spraying of viscous materials
- Variable atomization
- Moderate spray angle (60°- 90°)
- Precise metering of the liquid flow rate



1/4"XA EF 150 E  
XA 00 Body; E Hardware

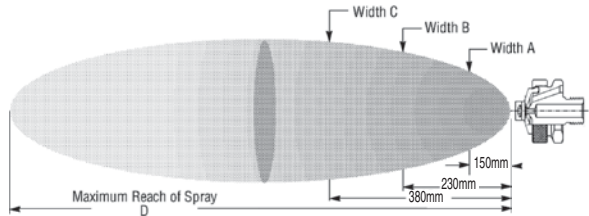

Dimensions are approximate. Check with BETE for critical dimension applications.

### XA EF Set-up Flow Rates and Dimensions

Pressure-fed, External Mix, Flat Fan Spray Pattern, 1/8" and 1/4" Pipe Sizes, BSP or NPT

Pipe Size	Spray Set-up Number	Fluid and Air Cap Numbers	0.2 Bar Liquid			0.3 Bar Liquid			0.7 Bar Liquid			1.5 Bar Liquid			3.0 Bar Liquid			Spray Dimensions									
			Air (bar)	l/h	Nm <sup>3</sup> /h	Air (bar)	l/h	Nm <sup>3</sup> /h	Air (bar)	l/h	Nm <sup>3</sup> /h	Air (bar)	l/h	Nm <sup>3</sup> /h	Air (bar)	l/h	Nm <sup>3</sup> /h	air	Bar liquid	A (mm)	B (mm)	C (mm)	D (m)				
1/8	EF 050	Fluid Cap FC7 & Air Cap AC1001	0.4		1.32	0.4		1.32	0.4		1.50	0.6		1.68	0.7		2.04	0.7		2.04	0.6	0.7	200	280	330	1.2	
			0.4		1.50	0.4		1.50	0.6		1.68	0.7		2.04	1.1		2.70	1.1		2.70	0.6	1.5	280	350	460	1.8	
			0.5	3	1.62	0.6	4	1.68	0.7	5	2.04	1.1	8	2.70	1.8	11	3.72	1.4	1.5	250	300	410	2.7				
			0.6		1.68	0.7		2.04	0.9		2.40	1.4		3.24	2.5		4.74	1.1	2.0	280	350	480	2.6				
																			1.4	3.0	300	380	510	2.7			
1/8	EF 100	Fluid Cap FC7 & Air Cap AC1003	0.2		1.51	0.4		1.58	0.7		1.87	1.4		2.72	2.8		4.38	0.2	0.2	90	150	230	0.9				
			0.4		1.58	0.7		1.87	1.1		2.38	1.8		3.23	3.5		5.10	1.1	0.2	90	150	230	1.2				
			0.7	3	1.87	1.1	4	2.38	1.4	5	2.72	2.1	8	3.57	4.2	11	6.12	1.4	0.4	100	150	230	1.2				
			1.1		2.38	1.4		2.72	1.8		3.23	2.8		3.56	5.3		7.65	1.4	1.4	120	180	250	1.5				
			1.4		2.72	1.8		3.23	2.1		3.56	3.5		5.10	5.3		7.65	1.8	0.7	120	150	240	1.5				
			1.8		3.23	2.1		3.56	2.8		4.42	4.2		6.12	5.6		8.34	2.8	1.4	130	180	280	1.8				
2.1		3.56	2.8		4.42	3.5		5.10	5.6		8.34	6.3		9.54	4.9	2.8	150	180	240	2.4							
1/8	EF 150	Fluid Cap FC4 & Air Cap AC1001	0.4		1.32	0.4		1.32	0.6		1.68	0.7		2.04	1.1		2.70	0.7	0.3	280	330	400	1.5				
			0.6		1.68	0.7		2.04	0.7		2.04	1.4		3.24	1.4		3.24	0.7	1.5	300	380	480	2.1				
			0.7	5	2.04	1.1	6	2.70	1.4	8	3.24	2.1	12	4.26	2.1	17	4.26	1.4	1.5	350	430	560	2.4				
			1.1		2.70	1.4		3.24	2.1		4.26	2.5		4.74	2.5		4.74	2.5	1.5	330	400	510	3.0				
																			1.8	2.0	380	460	580	2.7			
																			1.8	3.0	410	480	660	2.9			
1/4	EF 200	Fluid Cap FC4 & Air Cap AC1003	0.4		1.58	0.7		1.87	1.1		2.38	1.8		3.23	3.5		4.92	0.4	0.2	80	140	220	1.0				
			0.7		1.87	1.1		2.38	1.4		2.72	2.1		3.56	3.5		5.10	1.4	0.2	90	150	220	1.7				
			1.1	5	2.38	1.4	6	2.72	1.8	8	3.23	2.8	12	4.42	4.2	17	6.12	1.8	0.4	100	170	230	1.8				
			1.4		2.72	1.8		3.23	2.1		3.56	3.5		5.10	4.9		7.14	1.8	1.4	130	190	290	2.1				
			1.8		3.23	2.1		3.56	2.8		4.42	4.2		6.12	5.3		7.62	2.1	0.7	130	180	250	1.8				
			2.1		3.56	2.8		4.42	3.5		5.10	4.9		7.14	6.3		9.54	3.5	1.4	130	220	300	2.4				
2.8		4.42	3.5		5.10	4.2		6.12	6.3		9.54	6.7		9.84	5.3	2.8	150	190	250	3.0							
1/4	EF 250	Fluid Cap FC3 & Air Cap AC1001	0.4		1.50	0.4		1.50	0.4		1.50	0.7		2.04	1.4		3.24	0.6	0.3	350	480	610	1.8				
			0.5		1.65	0.6		1.68	0.6		1.68	0.9		2.40	1.8		3.72	0.7	1.5	380	480	630	1.8				
			0.6	9	1.68	0.7	10	1.86	0.7	16	2.04	1.1	23	2.70	2.1	33	4.26	1.1	1.5	410	510	660	2.1				
			0.7		2.04	0.7		2.04	0.9		2.40	1.4		3.24	2.5		4.74	1.4	1.5	430	530	660	2.4				
																		1.8	2.0	410	510	690	2.7				
																		2.1	3.0	410	510	690	2.9				
1/4	EF 300	Fluid Cap FC3 & Air Cap AC1003	0.7		1.87	1.1		2.38	1.4		2.72	2.5		4.08	3.5		5.10	0.7	0.2	130	170	250	1.2				
			1.1		2.38	1.4		2.72	1.8		3.23	2.8		4.42	4.2		6.12	1.8	0.2	130	170	250	1.8				
			1.4	9	2.72	1.8	10	3.23	2.1	16	3.56	3.5	23	5.10	4.9	33	7.14	2.1	0.4	130	180	240	1.8				
			1.8		3.23	2.1		3.56	2.8		4.42	4.2		6.12	5.3		7.62	2.5	1.4	140	200	320	1.8				
			2.1		3.56	2.8		4.42	3.5		5.10	4.9		7.14	5.6		8.34	2.8	0.7	140	190	300	2.3				
			2.8		4.42	3.5		5.10	4.2		6.12	5.6		8.34	6.3		9.54	4.2	1.4	140	200	360	3.0				
3.5		5.10	4.2		6.12	4.9		7.14	6.3		9.54	7.0		10.56	5.3	2.8	170	200	300	4.0							

Standard Materials: Nickel-plated Brass, 303 Stainless Steel, and 316 Stainless Steel

AIR ATOMIZING

TO ORDER: specify pipe size, body style, spray set-up #, hardware and mounting assemblies, and material. See page 78.

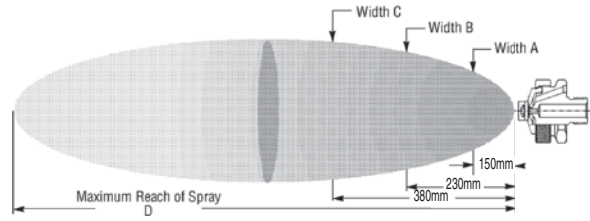

Dimensions are approximate. Check with BETE for critical dimension applications.

**XA EF Set-up Flow Rates and Dimensions**  
 Pressure-fed, External Mix, Flat Fan Spray Pattern, 1/8" and 1/4" Pipe Sizes, BSP or NPT

Pipe Size	Spray Set-up Number	Fluid and Air Cap Numbers	0.2 Bar Liquid			0.3 Bar Liquid			0.7 Bar Liquid			1.5 Bar Liquid			3.0 Bar Liquid			Spray Dimensions					
			Air (bar)	l/h	Nm <sup>3</sup> /h	Air (bar)	l/h	Nm <sup>3</sup> /h	Air (bar)	l/h	Nm <sup>3</sup> /h	Air (bar)	l/h	Nm <sup>3</sup> /h	Air (bar)	l/h	Nm <sup>3</sup> /h	air	liquid	A (mm)	B (mm)	C (mm)	D (m)
1/8 OR 1/4	EF 350	Fluid Cap FC6 & Air Cap AC1002	0.6		5.46	0.7		6.12	1.4		9.36	2.1		12.6	3.2		17.1	1.4	0.3	330	380	480	3.8
			0.7		6.12	1.1		7.80	2.1		12.6	2.8		15.6	4.2		21.6	2.1	0.7	330	400	560	4.3
			1.1	13	7.80	1.8		11.0	2.5		14.1	3.5		18.6	5.3		25.8	3.2	1.5	380	480	660	4.6
	1.4			9.36	2.1		12.6	2.8		15.6	3.5		21.6	5.6		27.3	4.2	1.5	380	480	640	5.2	
	1.4			9.36	2.1		12.6	2.8		15.6	4.2		21.6	5.6		27.3	3.9	2.0	410	510	690	4.6	
	1.4			9.36	2.1		12.6	2.8		15.6	4.2		21.6	5.6		27.3	3.9	2.0	410	510	690	4.6	
	EF 400	Fluid Cap FC6 & Air Cap AC1004	0.7		5.10	1.0		6.12	1.4		6.96	2.5		10.7	3.2		12.7	0.7	0.2	130	190	250	1.7
			1.0		6.12	1.4		6.96	1.8		8.34	2.8		11.7	3.5		13.9	1.8	0.2	130	190	250	2.7
			1.4	13	6.96	1.8		8.34	2.1		9.36	3.5		13.6	3.9		15.3	2.1	0.4	150	190	280	3.0
	1.8			8.34	2.1		9.36	2.5		10.7	4.2		16.0	4.2		16.5	2.5	0.7	150	220	280	3.5	
	2.1			9.36	2.8		11.7	2.8		11.7	4.9		18.7	4.9		18.8	2.5	1.4	170	230	360	3.7	
	2.8			11.7	3.5		13.6	3.5		13.6	5.6		21.6	5.6		21.6	4.2	1.4	170	230	370	4.3	
3.5		13.6	4.2		16.0	4.2		16.0	6.3		24.7	6.3		24.7	4.9	2.8	170	220	320	4.9			
EF 450	Fluid Cap FC2 & Air Cap AC1002	0.6		5.46	0.7		6.12	1.1		7.80	2.5		14.1	3.5		18.6	1.1	0.2	330	380	510	3.5	
		1.1		7.80	1.4		9.36	1.8		11.0	3.2		17.1	4.6		22.8	1.8	0.7	350	480	640	3.0	
		1.4	18	9.36	1.8		11.0	2.5		14.1	3.9		19.8	6.0		28.5	3.2	1.5	330	430	610	4.3	
1.8			11.0	2.1		12.6	2.8		15.6	4.2		21.6	6.7		31.5	4.2	2.0	300	430	580	4.9		
1.8			11.0	2.1		12.6	2.8		15.6	4.2		21.6	6.7		31.5	4.9	3.0	330	430	600	4.0		
1.8			11.0	2.1		12.6	2.8		15.6	4.2		21.6	6.7		31.5	4.9	3.0	330	430	600	4.0		
EF 500	Fluid Cap FC2 & Air Cap AC1004	0.7		5.10	1.4		6.96	1.8		8.34	2.8		11.7	3.5		13.9	0.7	0.4	150	190	270	2.1	
		1.0		6.12	1.8		8.34	2.1		9.36	3.2		12.7	4.2		16.5	1.8	0.7	150	190	270	3.0	
		1.4	18	6.96	2.1		9.36	2.5		10.7	3.5		13.6	4.9		18.8	2.5	1.4	150	220	330	3.4	
1.8			8.34	2.5		10.7	2.8		11.7	4.2		16.0	5.3		20.4	2.8	1.4	150	220	360	3.8		
2.1			9.36	2.8		11.7	3.5		13.6	4.9		18.7	5.6		21.6	2.8	1.4	170	250	370	4.0		
2.8			11.7	3.5		13.6	4.2		16.0	5.6		21.6	6.3		24.7	4.2	2.1	170	250	370	4.9		
3.5		13.6	4.2		16.0	4.9		18.7	6.3		24.7	6.6		25.7	5.3	2.8	180	230	360	5.8			
EF 550	Fluid Cap FC1 & Air Cap AC1002	0.7		6.12	1.1		7.80	1.8		11.0	3.2		17.1	5.3		25.8	2.1	0.3	400	560	760	3.0	
		1.1		7.80	1.4		9.36	2.1		12.6	3.5		18.6	6.0		28.5	2.8	0.7	460	580	810	4.0	
		1.4	36	9.36	2.1		12.6	2.8		15.6	4.9		24.3	6.7		31.5	4.6	1.5	430	530	760	4.9	
1.8			11.0	2.5		14.1	3.2		17.1	5.9		27.3	7.0		33.0	5.6	1.5	380	510	660	5.8		
1.8			11.0	2.5		14.1	3.2		17.1	5.9		27.3	7.0		33.0	6.3	2.0	480	640	840	4.3		
1.8			11.0	2.5		14.1	3.2		17.1	5.9		27.3	7.0		33.0	6.3	3.0	410	560	790	5.8		
EF 600	Fluid Cap FC1 & Air Cap AC1004	1.0		6.12	1.8		8.34	2.5		10.7	3.2		12.7	3.9		15.3	1.0	0.2	150	200	250	2.7	
		1.4		6.96	2.1		9.36	2.8		11.7	3.5		13.6	4.2		16.5	2.1	0.2	150	220	290	3.0	
		1.8	36	8.34	2.5		10.7	3.2		12.7	3.9		14.8	4.6		17.8	2.8	0.4	180	240	360	3.5	
2.1			9.36	2.8		11.7	3.5		13.6	4.2		16.0	4.9		18.8	3.2	1.4	200	280	390	3.7		
2.5			10.7	3.2		12.7	4.2		16.0	4.9		18.7	5.6		21.6	3.5	0.7	190	270	380	4.0		
2.8			11.7	3.5		13.6	4.9		18.7	5.6		21.6	6.3		24.7	4.2	1.4	200	280	390	4.3		
3.5		13.6	4.2		16.0	5.6		21.6	6.3		24.7	7.0		27.2	5.6	2.8	180	240	380	5.9			
EF 650	Fluid Cap FC8 & Air Cap AC1005	1.8		14.1	1.8		14.1	2.5		18.0	3.9		24.6				1.8	0.2	150	200	290	3.0	
		2.1		15.6	2.1		15.6	2.8		19.8	4.2		26.7				2.8	0.2	150	200	300	3.4	
		2.5	36	18.0	2.5		18.0	3.2		21.3	4.6		28.8				2.8	0.3	150	200	300	4.0	
2.8			19.8	2.8		19.8	3.5		22.8	4.9		31.2				3.5	0.7	170	220	320	4.3		
3.2			21.3	3.2		21.3	3.9		24.6	5.3		33.9				3.9	1.5	170	220	340	4.6		
3.5			22.8	3.5		22.8	4.2		26.7	5.6		36.0				4.2	1.0	170	230	330	4.7		
4.2		26.7	4.2		26.7	4.9		31.2	6.3		41.1				4.9	1.5	170	230	340	5.5			
EF 700	Fluid Cap FC9 & Air Cap AC1005	2.1		15.6	2.8		19.8	3.9		24.6	4.9		31.2				2.1	0.2	170	240	340	3.5	
		2.5		18.0	3.2		21.3	4.2		26.7	5.3		33.9				3.2	0.2	180	240	360	4.3	
		2.8	64	19.8	3.5		22.8	4.6		28.8	5.6		36.0				3.9	0.3	180	250	360	4.9	
3.2			21.3	3.9		24.6	4.9		31.2	6.0		38.4				4.9	0.7	180	250	360	5.5		
3.5			22.8	4.2		26.7	5.3		33.9	6.3		41.1				4.9	1.5	200	250	380	5.5		
4.2			26.7	4.9		31.2	5.6		36.0	6.3		41.1				5.3	1.0	180	250	380	5.8		
4.9		31.2	5.6		36.0	6.3		41.1	6.3		41.1				5.6	1.5	200	250	380	6.1			
EF 750	Fluid Cap FC5 & Air Cap AC1005	2.8		19.8	3.5		22.8	4.6		28.8	5.6		36.0				2.8	0.2	190	250	360	4.6	
		3.2		21.3	3.9		24.6	4.9		31.2	6.0		38.4				3.9	0.2	200	250	370	4.9	
		3.5	102	22.8	4.2		26.7	5.3		33.9	6.3		41.1				4.6	0.3	200	250	370	5.2	
3.9			24.6	4.6		28.8	5.6		36.0	6.3		41.1				5.3	0.7	220	270	380	5.5		
4.2			26.7	4.9		31.2	6.0		38.4	6.3		41.1				5.6	1.0	220	270	410	5.5		
4.6			28.8	5.3		33.9	6.3		41.1	6.3		41.1				5.6	1.5	220	270	410	5.8		
4.9		31.2	5.6		36.0	6.3		41.1	6.3		41.1				6.0	1.5	220	270	410	6.1			

Standard Materials: Nickel-plated Brass, 303 Stainless Steel, and 316 Stainless Steel

AIR ATOMIZING

CALL 413-772-0846  
 Call for the name of your nearest BETE representative.



# XAER

## Pressure-fed/Ext. Mix/Narrow Angle Round

- DESIGN/SPRAY CHARACTERISTICS**
- External mix: allows spraying of viscous liquids
  - Variable atomization
  - Narrow spray angle (10°- 30°)
  - Precise metering of liquid flow rate

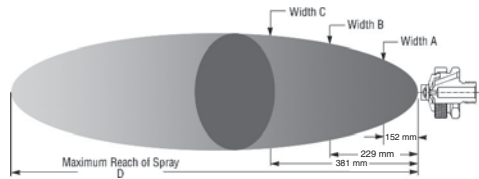

Dimensions are approximate. Check with BETE for critical dimension applications.



1/4" XAER850A  
XA 00 Body; A Hardware

### XA ER Set-up Flow Rates and Spray Dimensions Pressure-fed, External Mix, Narrow Round Spray Pattern, 1/8" and 1/4" Pipe Sizes

Pipe Size	Spray Set-up Number	Fluid and Air Cap Numbers	0.2 BAR Liquid			0.3 BAR Liquid			0.7 BAR Liquid			1.5 BAR Liquid			3 BAR Liquid			Spray Dimensions								
			BAR air	L/h	Nm <sup>3</sup> /h	BAR air	L/h	Nm <sup>3</sup> /h	BAR air	L/h	Nm <sup>3</sup> /h	BAR air	L/h	Nm <sup>3</sup> /h	BAR air	L/h	Nm <sup>3</sup> /h	Liquid	AIR	A mm	B mm	C mm	D mm			
1/8"	ER 050	Fluid Cap FC7 & Air Cap AC1801	0.3	2.7	1.3	0.3	3	1.3	0.3	4.4	1.3	0.7	1.9	1.4	1.4	2.9	1.4	2.9	2.9	0.2	0.7	50	90	130	2.3	
			0.7	1.9	0.7	1.9	1.4	2.9	2.1	2.9	2.1	2.9	2.1	3.7	2.8	3.4	4.6	3.4	4.6	0.3	1.4	60	90	110	3	
			1.4	2.9	1.4	2.9	2.1	3.7	2.8	4.6	3.4	4.6	3.4	5.6	4.1	5.6	4.1	6.5	4.1	6.5	0.7	2.8	40	90	130	3.7
			2.1	3.7	2.1	3.7	2.8	4.6	3.4	5.6	4.1	5.6	4.1	8.5	6.2	9.4	6.2	9.4	3.0	4.1	70	70	100	60	80	4.3
1/8"	ER 150	Fluid Cap FC4 & Air Cap AC1801	0.3	3.7	1.3	0.3	4.5	1.3	0.7	7.4	1.9	1.4	2.9	2.1	2.1	3.7	2.8	4.6	2.9	0.2	0.7	50	60	80	3	
			0.7	1.9	0.7	1.9	1.4	2.9	2.1	3.7	2.8	3.4	4.6	3.4	4.6	3.4	5.6	4.1	6.5	0.3	1.4	60	60	110	4.9	
			1.4	2.9	1.4	2.9	2.1	3.7	2.8	4.6	3.4	5.6	4.1	6.5	4.1	6.5	4.1	7.6	4.8	6.5	0.7	2.8	60	80	100	5.5
			2.1	3.7	2.8	4.6	3.4	5.6	4.1	6.5	4.1	6.5	4.1	9.4	6.2	9.4	6.2	9.4	3.0	4.1	80	80	100	100	140	6.1
1/8"	ER 250	Fluid Cap FC3 & Air Cap AC1801	0.4	7.7	1.4	0.7	9.5	1.9	0.7	15	1.9	1.4	2.9	2.1	2.1	3.7	2.8	4.6	4.6	0.2	0.7	80	90	100	3	
			0.7	1.9	0.7	1.9	1.4	2.9	2.1	3.7	2.8	3.4	4.6	3.4	4.6	3.4	5.6	4.1	6.5	0.3	1.4	80	80	130	4.3	
			1.4	2.9	1.4	2.9	2.1	3.7	2.8	4.6	3.4	5.6	4.1	6.5	4.1	6.5	4.1	7.6	4.8	6.5	0.7	2.8	70	80	120	4.3
			2.1	3.7	2.8	4.6	3.4	5.6	4.1	6.5	4.1	6.5	4.1	9.4	6.2	9.4	6.2	9.4	3.0	4.1	80	90	130	5.2		
1/8"	ER 350	Fluid Cap FC6 & Air Cap AC1802	0.7	12	5.5	0.7	15	5.5	1.4	22	8.8	2.1	11.6	3.4	3.4	4.6	3.4	5.5	2.8	0.2	0.7	80	130	150	2.7	
			1.0	7.2	1.4	1.0	1.4	8.8	2.1	11.6	3.4	4.1	19.6	4.8	4.8	5.5	25.1	6.2	26.9	0.3	1.4	80	100	150	3.4	
			1.4	11.6	2.8	14.3	3.4	17	4.1	19.6	4.1	19.6	4.1	22.3	4.8	25.1	6.2	26.9	3.0	4.1	80	100	150	4.9		
			2.8	14.3	3.4	17	4.1	19.6	4.1	19.6	4.1	19.6	4.1	25.1	6.2	26.9	6.2	26.9	3.0	4.1	80	130	180	5.2		
1/4"	ER 450	Fluid Cap FC2 & Air Cap AC1802	0.7	19	5.5	0.7	23	5.5	1	33	7.2	2.1	11.6	3.4	3.4	4.6	3.4	5.5	2.8	0.2	0.7	100	140	210	4.3	
			1.4	11.6	2.1	1.4	1.4	8.8	2.1	11.6	3.4	4.1	19.6	4.8	4.8	5.5	25.1	6.2	26.9	0.3	1.4	110	130	150	5.5	
			2.1	11.6	2.1	14.3	3.4	17	4.1	19.6	4.1	19.6	4.1	22.3	4.8	25.1	6.2	26.9	3.0	4.1	80	100	140	6.4		
			2.8	14.3	3.4	17	4.1	19.6	4.1	19.6	4.1	19.6	4.1	25.1	6.2	26.9	6.2	26.9	3.0	4.1	100	130	180	6.7		
1/4"	ER 550	Fluid Cap FC1 & Air Cap AC1802	1	39	7.2	1.4	46	8.8	2.8	68	11.6	3.4	14.3	3.4	3.4	4.6	3.4	5.5	2.8	0.2	1.4	140	150	220	4.9	
			1.4	8.8	2.1	1.4	1.4	11.6	2.8	14.3	3.4	4.1	19.6	4.8	4.8	5.5	25.1	6.2	26.9	0.3	1.4	130	150	230	4.6	
			2.1	11.6	2.8	14.3	3.4	17	4.1	19.6	4.1	19.6	4.1	22.3	4.8	25.1	6.2	26.9	3.0	4.1	100	130	180	6.4		
			2.8	14.3	3.4	17	4.1	19.6	4.1	19.6	4.1	19.6	4.1	25.1	6.2	26.9	6.2	26.9	3.0	4.1	130	170	240	6.7		
1/4"	ER650	Fluid Cap FC8 & Air Cap AC1803	1.0	39	11.6	1.4	46	14.1	2.1	68	18.8	3.4	27.7	4.1	4.1	5.5	6.2	6.2	6.2	0.2	1.4	130	150	200	5.2	
			1.4	14.1	1.7	1.4	1.4	16.6	2.8	18.8	3.4	4.1	23.2	3.8	4.1	4.1	4.1	4.1	4.1	0.3	2.1	150	140	150	6.7	
			1.7	16.6	2.1	1.4	1.4	18.8	2.8	23.2	3.8	4.1	27.7	4.1	4.1	4.1	4.1	4.1	4.1	0.3	3.4	120	130	160	6.7	
			2.1	18.8	2.8	23.2	3.4	27.7	4.1	29.8	4.5	31.9	4.8	36.1	6.2	44.8	4.8	4.8	4.8	0.7	4.1	130	140	170	6.7	
1/4"	ER750	Fluid Cap FC9 & Air Cap AC1803	1.4	65	14.1	2.1	76	18.8	2.8	110	23.2	3.4	34	4.5	4.5	4.5	4.5	4.5	4.5	0.2	1.4	150	150	220	5.8	
			2.1	18.8	2.8	2.1	2.1	23.2	3.4	27.7	4.1	31.9	4.1	3.4	4.5	4.5	4.5	4.5	4.5	0.3	2.1	140	160	200	6.4	
			2.8	23.2	3.4	2.1	2.1	27.7	4.1	31.9	4.1	31.9	4.1	36.1	4.8	40.5	5.5	44.8	4.8	0.7	4.1	150	170	180	6.7	
			3.4	27.7	4.1	2.1	2.1	31.9	4.5	34	4.8	36.1	4.8	40.5	5.5	44.8	4.8	4.8	4.8	1.5	3.4	130	130	200	6.7	
1/4"	ER850	Fluid Cap FC5 & Air Cap AC1803	2.8	95	23.2	3.8	109	29.8	4.5	158	34	5.5	40.5	6.2	6.2	6.2	6.2	6.2	6.2	0.2	2.8	150	160	180	6.7	
			3.4	27.7	4.1	3.8	3.8	31.9	4.8	34	5.5	36.1	4.8	40.5	6.2	44.8	6.2	44.8	6.2	0.3	4.8	90	110	150	5.8	
			3.8	29.8	4.5	3.8	3.8	34	5.5	36.1	4.8	36.1	4.8	40.5	6.2	44.8	6.2	44.8	6.2	0.7	6.2	80	100	150	5.5	
			4.1	31.9	4.8	3.8	3.8	36.1	5.5	36.1	4.8	36.1	4.8	40.5	6.2	44.8	6.2	44.8	6.2	1.5	5.5	90	100	150	5.5	
1/4"	ER850	Fluid Cap FC5 & Air Cap AC1803	4.5	34	5.5	5.5	40.5	6.2	40.5	6.2	40.5	6.2	44.8	6.2	44.8	6.2	44.8	6.2	1.5	6.2	80	100	140	5.8		
			4.5	34	5.5	5.5	40.5	6.2	40.5	6.2	40.5	6.2	44.8	6.2	44.8	6.2	44.8	6.2	44.8	6.2	1.5	6.2	80	100	140	5.8

Standard Materials: Nickel Plated Brass, 303 Stainless Steel, and 316 Stainless Steel.

AIR ATOMIZING

TO ORDER: specify pipe size, body style, spray set-up #, hardware and mounting assemblies, and material. See page 78.

# XAFF

## Pressure-fed/Int. Mix/Deflected Flat Fan

### DESIGN/SPRAY CHARACTERISTICS

- Internal mix
- Very fine atomization
- Deflected flat fan spray pattern

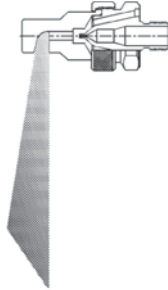

1/4" XA 01 FF050 F  
XA01 Body; F Hardware

### XA FF Set-up Flow Rates

Pressure-fed, Internal Mix, Deflected Flat Fan Spray Pattern, 1/8" and 1/4" Pipe Sizes, BSP or NPT

Pipe Size	Spray Set-up Number	Fluid and Air Cap Numbers	0.7 Bar Liquid			1.5 Bar Liquid			2.0 Bar Liquid			3.0 Bar Liquid			4.0 Bar Liquid		
			Air (bar)	l/hr	Nm <sup>3</sup> /hr	Air (bar)	l/hr	Nm <sup>3</sup> /hr	Air (bar)	l/hr	Nm <sup>3</sup> /hr	Air (bar)	l/hr	Nm <sup>3</sup> /hr	Air (bar)	l/hr	Nm <sup>3</sup> /hr
1/8 or 1/4	FF 050	Fluid Cap FC10 & Air Cap AC1701	0.4	11.0	2.70	1.1	14.5	4.74	1.5	15.7	5.76	2.1	20.0	6.84	2.7	26.0	7.98
			0.6	9.5	3.24	1.3	13.2	5.16	1.7	14.3	6.24	2.2	19.2	7.26	3.2	22.0	9.60
			0.7	7.6	3.90	1.4	11.8	5.70	1.8	12.9	6.72	2.7	15.8	8.76	3.8	17.7	11.2
			0.8	5.7	4.62	1.5	10.0	6.18	2.1	9.8	7.80	3.1	11.8	10.4	4.4	13.1	13.8
						1.7	8.7	6.78	2.2	8.3	8.52	3.2	10.3	11.0	4.6	10.2	15.0

# XAxw

## Pressure-fed/Int. Mix/Extra-wide Angle

### DESIGN/SPRAY CHARACTERISTICS

- Internal mix
- Very fine atomization
- 180° Extra-wide Hollow Cone

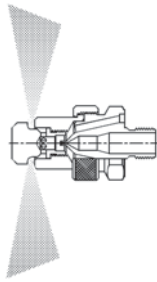

1/4" XA 03 XW050 A  
XA 03 Body; A Hardware

### XA XW Set-up Flow Rates

Pressure-fed, Internal Mix, Extra-wide Spray Pattern, 1/8" and 1/4" Pipe Sizes, BSP or NPT

Pipe Size	Spray Set-up Number	Fluid and Air Cap Numbers	0.7 Bar Liquid			1.5 Bar Liquid			2.0 Bar Liquid			3.0 Bar Liquid			4.0 Bar Liquid		
			Air (bar)	l/h	Nm <sup>3</sup> /h	Air (bar)	l/h	Nm <sup>3</sup> /h	Air (bar)	l/h	Nm <sup>3</sup> /h	Air (bar)	l/h	Nm <sup>3</sup> /h	Air (bar)	l/h	Nm <sup>3</sup> /h
1/8 or 1/4	XW 050	Fluid Cap FC8 & Air Cap AC1401	1.4	15.1	4.14	2.8	19.5	8.52	3.5	21.0	11.1	4.2	48.0	12.6	6.0	45.0	20.4
			1.5	10.6	4.62	3.0	16.1	9.18	3.7	17.6	11.8	4.6	37.0	14.4	6.3	37.0	22.5
			1.7	7.6	5.04	3.1	13.2	9.90	3.8	14.8	12.6	4.9	28.0	16.5	6.7	30.0	24.3
			1.8	5.7	5.58	3.2	10.6	10.6	3.9	12.5	13.2	5.6	15.5	20.4	7.0	24.0	26.4
			2.0	4.2	6.18	3.4	8.3	11.3	4.2	8.1	14.7	6.3	7.8	25.5			

Standard Materials: Nickel-plated Brass, 303 Stainless Steel, and 316 Stainless Steel

AIR ATOMIZING

CALL 413-772-0846  
Call for the name of your nearest BETE representative.

# 1/2 XA

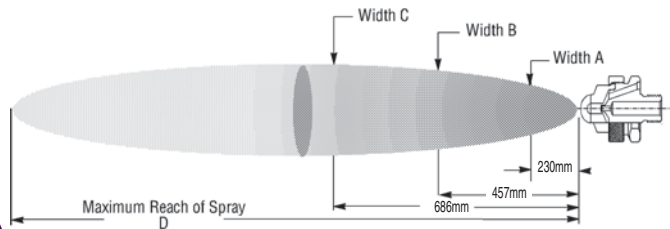

## Air Atomizing

Dimensions are approximate. Check with BETE for critical dimension applications.

### AD 1/2" XA AD Set-up Flow Rates and Dimensions Pressure-fed, Internal Mix, Wide Angle Round Spray Pattern, 1/2" Pipe Size, BSP or NPT

Pipe Size	Spray Set-up Number	Fluid and Air Cap Numbers	0.35 Bar Liquid			1.0 Bar Liquid			2.0 Bar Liquid			3.0 Bar Liquid			4.0 Bar Liquid			Spray Dimensions						
			Air (bar)	l/h	Nm <sup>3</sup> /h	Air (bar)	l/h	Nm <sup>3</sup> /h	Air (bar)	l/h	Nm <sup>3</sup> /h	Air (bar)	l/h	Nm <sup>3</sup> /h	Air (bar)	l/h	Nm <sup>3</sup> /h	air	liquid	A (mm)	B (mm)	C (mm)	D (m)	
1/2	AD 5050	Fluid Cap FC501 & Air Cap AC5601							2.1	213	10.6	3.1	316	12.8	4.2	238	21.1	2.1	2.0	360	480	690	6.7	
									2.3	127	14.9	3.2	195	17.5	4.3	154	26.3	3.2	3.0	360	480	690	7.3	
												3.4	107	22.3	4.5	100	31.3	4.3	4.0	360	480	690	8.5	
	AD 5100	Fluid Cap FC501 & Air Cap AC5602	0.6	102	11.0	1.1	215	9.18	2.5	185	21.3	3.7	192	33.6	5.0	230	49.8	0.7	0.35	330	470	650	6.1	
			0.7	57	13.8	1.3	124	13.8	2.7	146	24.6	3.9	150	37.2	5.3	158	56.4	1.3	1.0	340	480	670	7.9	
			0.85	32	16.8	1.4	84	16.8	2.8	112	27.9	4.0	119	40.8	5.6	108	64.8	2.8	2.0	330	470	650	6.4	
									3.0	86	31.2	4.2	86	46.2				4.0	3.0	340	480	670	7.3	
									3.1	65	34.8	4.6	51					5.3	4.0	360	480	690	8.2	
	AD 5150	Fluid Cap FC501 & Air Cap AC5603	0.7	129	19.5	1.7	182	32.4	3.1	265	48.6	4.3	350	60.0				0.85	0.35	360	500	690	7.9	
			0.85	82	22.2	1.8	143	35.4	3.2	215	51.6	4.6	260	64.8				1.7	1.0	330	480	660	7.3	
			1.0	45	24.9				3.4	173	54.6	5.0	186	72.0				3.4	2.0	330	470	660	7.0	
									3.5	136	57.0							4.6	3.0	360	500	690	8.5	
									3.6	120	58.8													
	AD 5200	Fluid Cap FC502 & Air Cap AC5604	0.7	134	18.9	1.3	320	26.4	2.1	575	34.2	3.0	740	42.6	3.9	840	51.6	0.7	0.35	330	640	910	3.4	
			0.85	100	22.8	1.4	255	31.2	2.2	505	38.4	3.1	690	46.2	4.1	790	55.8	1.4	1.0	330	660	910	4.9	
						1.5	200	35.4	2.4	440	43.2	3.2	630	50.4	4.2	740	59.4	2.5	2.0	280	560	810	6.1	
					1.7	154	40.2	2.5	380	47.4	3.4	570	54.6	4.4	690	64.2	3.4	3.0	280	530	740	6.7		
								2.7	330	51.6	3.5	520	58.8	4.5	650	68.4	4.5	4.0	280	560	790	7.6		
								2.8	275	55.8	3.7	470	63.0	4.6	600	72.6								
								3.0	235	60.6	3.8	420	67.2	4.8	550	76.8								
								3.1	195	64.8	3.9	345	71.4	4.9	510	81.0								
											4.1	325	75.6	5.1	465	85.8								
														5.2	425	89.4								
														5.3	390	93.6								
												5.5	350	98.4										

### PR 1/2" XA PR Set-up Flow Rates and Dimensions Pressure-fed, Internal Mix, Round Spray Pattern, 1/2" Pipe Size, BSP or NPT

Pipe Size	Spray Set-up Number	Fluid and Air Cap Numbers	0.35 Bar Liquid			1.0 Bar Liquid			2.0 Bar Liquid			3.0 Bar Liquid			4.0 Bar Liquid			Spray Dimensions							
			Air (bar)	l/h	Nm <sup>3</sup> /h	Air (bar)	l/h	Nm <sup>3</sup> /h	Air (bar)	l/h	Nm <sup>3</sup> /h	Air (bar)	l/h	Nm <sup>3</sup> /h	Air (bar)	l/h	Nm <sup>3</sup> /h	air	liquid	A (mm)	B (mm)	C (mm)	D (m)		
1/2	PR 5050	Fluid Cap FC501 & Air Cap AC5501	1.3	34	21.0	1.7	146	21.9	3.0	230	30.6							1.4	0.35					6.7	
			1.4	25	23.4	1.8	121	23.7	3.1	200	33.0				2.0	1.0								7.3	
			1.5	20	24.9	2.0	102	25.8	3.2	176	35.4				3.2	2.0		90	160	250				8.2	
						2.1	86	27.6	3.4	154	37.2														
						2.3	72	29.4	3.5	135	39.6														
	PR 5100	Fluid Cap FC502 & Air Cap AC5502	0.7	134	18.9	1.3	320	26.4	2.1	575	34.2	3.0	740	42.6	3.9	840	51.6	0.7	0.35	100	180	230	7.0		
			0.85	100	22.8	1.4	255	31.2	2.2	505	38.4	3.1	690	46.2	4.1	790	55.8	1.4	1.0	150	250	330	6.4		
						1.5	200	35.4	2.4	440	43.2	3.2	630	50.4	4.2	740	59.4	2.5	2.0	130	200	250	11.3		
						1.7	154	40.2	2.5	380	47.4	3.4	570	54.6	4.4	690	64.2	3.4	3.0	100	180	250	12.5		
									2.7	330	51.6	3.5	520	58.8	4.5	650	68.4	4.5	4.0	100	180	250	14.3		
						2.8	275	55.8	3.7	470	63.0	4.6	600	72.6											
						3.0	235	60.6	3.8	420	67.2	4.8	550	76.8											
						3.1	195	64.8	3.9	345	71.4	4.9	510	81.0											
									4.1	325	75.6	5.1	465	85.8											
												5.2	425	89.4											
												5.3	390	93.6											
												5.5	350	98.4											

Standard Materials: Nickel-plated Brass, 303 Stainless Steel, and 316 Stainless Steel

AIR ATOMIZING

TO ORDER: specify pipe size, body style, spray set-up #, hardware and mounting assemblies, and material. See page 78.

Dimensions are approximate. Check with BETE for critical dimension applications.

**EF**

**1/2" XA EF Set-up Flow Rates and Dimensions**

Pressure-fed, External Mix, Flat Fan Spray Pattern, 1/2" Pipe Size, BSP or NPT

Pipe Size	Spray Set-up Number	Fluid and Air Cap Numbers	0.2 Bar Liquid			0.35 Bar Liquid			0.5 Bar Liquid			0.7 Bar Liquid			1.0 Bar Liquid			Spray Dimensions					
			Air (bar)	l/h	Nm <sup>3</sup> /h	Air (bar)	l/h	Nm <sup>3</sup> /h	Air (bar)	l/h	Nm <sup>3</sup> /h	Air (bar)	l/h	Nm <sup>3</sup> /h	Air (bar)	l/h	Nm <sup>3</sup> /h	bar air	bar liquid	A (mm)	B (mm)	C (mm)	D (m)
1/2	EF 5050	Fluid Cap FC501 & Air Cap AC5001	2.1		52.6	2.8		64.5	3.2		70.4	3.9		81.5	5.6		110	2.5	0.2	216	368	520	5.80
			2.5		57.7	3.2		70.4	3.5		76.4	4.2		87.4	6.0		117	3.5	0.4	229	420	550	6.71
			2.8	522	64.5	3.5	681	76.4	3.9	795	81.5	4.9	953	98.4	6.3	1158	122	3.9	0.5	241	445	580	7.02
			3.2		70.4	3.9		81.5	4.2		87.4	4.6		93.3	5.6		110	4.9	0.7	241	460	610	7.63
									4.2		4.9		117	6.0		132	6.3	1.0	254	480	660	8.85	

**PF**

**1/2" XA PF Set-up Flow Rates and Dimensions**

Pressure-fed, Internal Mix, Flat Fan Spray Pattern, 1/2" Pipe Size, BSP or NPT

Pipe Size	Spray Set-up Number	Fluid and Air Cap Numbers	0.35 Bar Liquid			1.0 Bar Liquid			2.0 Bar Liquid			3.0 Bar Liquid			4.0 Bar Liquid			Spray Dimensions								
			Air (bar)	l/h	Nm <sup>3</sup> /h	Air (bar)	l/h	Nm <sup>3</sup> /h	Air (bar)	l/h	Nm <sup>3</sup> /h	Air (bar)	l/h	Nm <sup>3</sup> /h	Air (bar)	l/h	Nm <sup>3</sup> /h	bar air	bar liquid	A (mm)	B (mm)	C (mm)	D (m)			
1/2	PF 5050	Fluid Cap FC501 & Air Cap AC5301				1.8	154	35.4	3.4	184	57.0							2.0	1.0	460	740	910	5.8			
						2.0	119	38.4	3.5	157	60.6								3.5	2.0	510	790	970	7.0		
						2.1	93	41.4	3.7	133	63.6	3.8	112	66.6												
	PF 5100	Fluid Cap FC502 & Air Cap AC5302	0.7	134	18.9	1.3	320	26.4	2.1	575	34.2	3.0	740	40.8	3.9	840	51.6	0.7	0.35	510	860	1190	4.0			
			0.85	100	22.8	1.4	255	31.2	2.2	505	38.4	3.1	690	43.2	4.1	790	55.8	1.4	1.0	860	1570	2110	4.6			
						1.5	200	35.4	2.4	440	43.2	3.2	630	46.1	4.2	740	59.4	2.5	2.0	860	1570	2080	5.2			
						1.7	154	40.2	2.5	380	47.4	3.4	570	50.8	4.4	690	64.2	3.4	3.0	910	1680	2160	5.8			
									2.7	330	51.6	3.5	520	54.1	4.5	650	68.4	4.5	4.0	910	1700	2260	6.4			
									2.8	275	55.8	3.7	470	59.3	4.6	600	72.6									
									3.0	235	60.6	3.8	420	63.3	4.8	550	76.8									
									3.1	195	64.8	3.9	345	69.2	4.9	510	81.0									
												4.1	325	74.1	5.1	465	85.8									
												5.2	425	89.4												
												5.3	390	93.6												
												5.5	350	98.4												

AIR ATOMIZING

**SR**

**1/2" XA SR Set-up Flow Rates and Dimensions**

Siphon-fed, External Mix, Round Spray Pattern, 1/2" Pipe Size, BSP or NPT

Pipe Size	Set-up Number	Fluid and Air Cap Numbers	ATOMIZING AIR		Liquid Capacity in l/h (Liters Per Hour)							Spray Dimensions at 200 mm Siphon Ht.					
			Air (bar)	Air Capacity (Nm <sup>3</sup> /h)	Gravity Head			Siphon Height				Air (bar)	B (mm)	D (m)			
					450 mm	300 mm	150 mm	100 mm	200 mm	300 mm	600 mm						
1/2	SR 5050	Fluid Cap FC501 & Air Cap AC5201	0.7	21.6						40					1.5		6.1
			1.5	34.2					97	64				2.0		6.7	
			2.0	39.6					117	90				3.0		7.3	
			3.0	52.2					150	123	90			3.5	150	7.9	
			3.5	59.4	300	260	225	163	133	104				4.0		8.8	
			4.0	66.0	305	270	240	170	143	115				5.0		9.8	
			5.0	78.0	315	280	250	183	157	129		53		5.6		10.7	
			5.6	87.0	320	290	255	188	164	136		62					

**XW**

**1/2" XA XW Set-up Flow Rates and Dimensions**

Pressure-fed, Internal Mix, Extra-wide Angle, Hollow Cone Spray Pattern, 1/2" Pipe Size, BSP or NPT

Pipe Size	Spray Set-up Number	Fluid and Air Cap Numbers	0.7 Bar Liquid			1.4 Bar Liquid			2.1 Bar Liquid			2.8 Bar Liquid			4.2 Bar Liquid		
			Air (bar)	l/h	Nm <sup>3</sup> /h	Air (bar)	l/h	Nm <sup>3</sup> /h	Air (bar)	l/h	Nm <sup>3</sup> /h	Air (bar)	l/h	Nm <sup>3</sup> /h	Air (bar)	l/h	Nm <sup>3</sup> /h
1/2	XW 5050	Fluid Cap FC502 & Air Cap AC5401	1.0	213	20.7	1.7	394	27.2	2.5	439	38.0	3.4	462	47.2	5.0	484	68.3
			1.1	145	25.1	1.8	324	31.6	2.7	372	42.1	3.5	416	50.6	5.2	439	71.8
			1.3	98	34.5	2.0	275	34.4	2.8	322	45.0	3.7	372	53.4	5.3	409	75.2
			1.4	59	32.3	2.1	207	38.5	3.0	277	49.1	3.8	325	57.3	5.5	366	78.6
						2.3	159	42.1	3.1	272	52.4	3.9	282	61.1	5.6	325	82.0
						2.4	116	45.5	3.2	188	55.8	4.1	250	65.0	5.8	297	85.7
						2.5	93	49.7	3.4	145	59.4	4.2	209	68.1	5.9	257	89.1
						2.7	27	54.0	3.5	114	63.0	4.4	168	71.3	6.0	232	93.0
									4.5	141	75.5	6.3	182	100			
									4.6	77	77.7						

Standard Materials: Nickel-plated Brass, 303 Stainless Steel, and 316 Stainless Steel

CALL 413-772-0846  
or  
Call for the name of your nearest BETE representative.



# SAM

## External Mix/Flat Fan or Narrow Round

### DESIGN FEATURES

- Separate atomizing and fan air lines provide variable coverage and fine control of drop size without affecting liquid flow rates. Higher atomizing air pressure yields finer drop size; higher fan air pressure yields broader patterns
- Pneumatically-controlled shut-off and clean-out built in
- External mix; allows spraying of viscous materials
- Liquid flow rates are independent of air
- Precise metering of the liquid flow rate
- Removable plug provided for liquid recirculation port

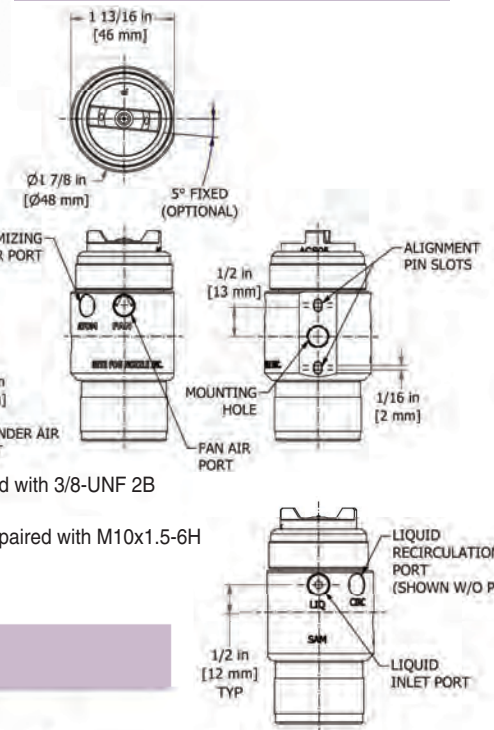
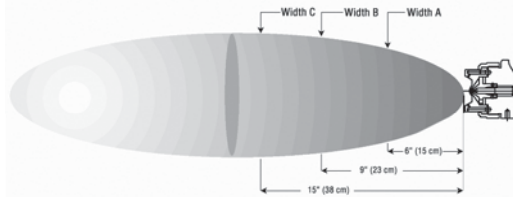

- 1/8" NPT air & liquid ports paired with 3/8-UNF 2B mounting threads
- 1/8" Rp (BSP) air & liquid ports paired with M10x1.5-6H mounting threads

SAM		Liquid Flow Rates						
Pipe Size	Spray Set-up Number	Fluid Cap and Air Cap No.	0.2 bar	0.3 bar	0.5 bar	0.7 bar	1 bar	1.5 bar
1/8	SAM-01-02	FCS 01 & ACS 02	2.7	3.3	4.3	5.1	6.2	7.6
	SAM-02-02	FCS 02 & ACS 02	4.5	5.5	7.2	8.5	10.2	12.5
	SAM-03-02	FCS 03 & ACT 02	8.8	10.8	14.0	16.6	19.9	24
	SAM-04-03	FCS 04 & ACS 03	13.5	16.5	21	25	30	37
	SAM-05-03	FCS 05 & ACS 03	17.2	21	27	32	38	46
	SAM-06-04	FCS 06 & ACS 04	37	46	60	72	86	107
	SAM-07-05	FCS 07 & ACS 05	59	74	97	116	140	174

SAM		Air Flow Rates												
Pipe Size	Spray Set-up Number	Fluid Cap and Air Cap No.	Atomizing Air Capacity Nm <sup>3</sup> /h @ bar								Fan Air Capacity Nm <sup>3</sup> /h @ bar			
			0.7 bar	1 bar	1.5 bar	2 bar	2.5 bar	3 bar	4 bar	5 bar	6 bar	2.5 bar	3 bar	
1/8	SAM-01-02	FCS 01 & ACS 02												
	SAM-02-02	FCS 02 & ACS 02	0.8	1.0	1.3	1.6	1.9	2.2	2.8	3.3	3.9			
	SAM-03-02	FCS 03 & ACS 02												
	SAM-04-03	FCS 04 & ACS 03	2.8	3.3	4.1	5.0	5.8	6.7	8.3	10.0	11.7			
	SAM-05-03	FCS 05 & ACS 03												
	SAM-06-04	FCS 06 & ACS 04	3.5	4.1	5.1	6.2	7.2	8.2	10.2	12.3	14.3			
	SAM-07-05	FCS 07 & ACS 05	4.5	5.3	6.7	8.0	9.3	10.6	13.3	15.9	18.5			
1/8	SAM-01-02	FCS 01 & ACS 02												
	SAM-02-02	FCS 02 & ACS 02	2.7	3.2	4.1	4.9	5.8	6.6	8.3	10.0	11.8			
	SAM-03-02	FCS 03 & ACS 02												
	SAM-04-03	FCS 04 & ACS 03	5.0	6.1	7.8	9.6	11.3	13.1	16.6	20	24			
	SAM-05-03	FCS 05 & ACS 03												
	SAM-06-04	FCS 06 & ACS 04	5.7	6.9	9.0	11.2	13.3	15.4	19.6	24	28			
	SAM-07-05	FCS 07 & ACS 05	5.9	7.2	9.3	11.4	13.6	15.7	20.0	24	29			

Standard Materials: 303 Stainless Steel, Blue-Gard® Gasket, Viton® O-rings

Spray angle performance varies with pressure. Contact BETE for specific data on critical applications.

**Note:** Spray set-ups consist of fluid and air caps. Set-ups are interchangeable but each clean-out/shut-off needle uses a different needle size.

**Pneumatically-Controlled Clean-out/Shut-off.** Removal of air pressure to the cylinder causes a spring loaded poppet valve actuator to shut off liquid flow and extends a clean-out needle through the nozzle orifice.

Replacement air caps include replacement Blue-Gard® gaskets.

Dimensions are approximate. Check with BETE for critical dimension applications.

**SAM Coverage Chart**

Variable Spray, Pressure Fed, Flat Fan or \*Narrow Round Spray Pattern

Pipe Size	Spray Set-up Number	Fluid Cap and Air Cap No.	Spray Dimensions with Varied Fan Air Pressure													
			bar air	bar liquid	0* bar			0.7 bar			2.5 bar			4 bar		
					A (mm)	B (mm)	C (mm)	A (mm)	B (mm)	C (mm)	A (mm)	B (mm)	C (mm)	A (mm)	B (mm)	C (mm)
1/8	SAM-01-02	FCS 01 & ACS 02	0.7	0.2	50	80	100	180	230	250	150	200	280	150	200	280
				0.7	60	90	110	180	250	300	180	200	280	180	200	300
				1.5	50	80	100	200	300	360	230	280	360	200	250	330
			2	0.2	50	80	110	130	150	180	200	250	360	200	280	360
				0.7	50	60	130	150	180	250	200	250	330	200	250	300
				1.5	50	80	100	180	230	330	250	300	380	240	290	370
			2.5	0.2	60	90	150	130	150	200	200	250	360	230	280	360
				0.7	50	80	130	150	180	250	230	280	360	230	280	330
				1.5	50	80	110	180	200	300	250	300	360	250	300	380
			4	0.2	60	90	150	100	130	150	200	280	330	230	280	360
				0.7	50	80	130	110	130	180	200	250	360	230	300	380
				1.5	50	80	110	130	180	230	230	300	410	250	330	430
1/8	SAM-02-02	FCS 02 & ACS 02	0.7	0.2	50	80	100	200	250	300	160	220	280	150	230	300
				0.7	60	90	110	200	300	380	230	360	460	180	250	330
				1.5	50	80	100	200	300	380	200	300	380	200	250	330
			2	0.2	50	80	110	140	180	200	200	250	360	200	280	360
				0.7	50	80	130	180	230	300	250	300	360	230	250	330
				1.5	50	80	100	180	250	300	330	410	460	240	290	370
			2.5	0.2	60	90	150	130	180	230	200	250	360	230	280	360
				0.7	50	80	130	180	200	160	240	300	360	230	300	380
				1.5	50	80	110	160	230	320	290	380	430	280	360	460
			4	0.2	60	90	150	110	140	180	200	270	330	230	280	360
				0.7	60	100	140	130	150	220	230	280	360	250	300	380
				1.5	50	80	110	140	190	240	250	360	460	280	360	460
1/8	SAM-03-02	FCS 03 & ACS 02	0.7	0.2	50	80	130	230	300	380	180	230	280	180	230	300
				0.7	50	60	100	300	380	530	300	510	580			
				1.5	50	80	100	250	300	410						
			2	0.2	60	80	110	150	200	230	200	250	330	200	250	330
				0.7	50	80	130	200	280	380	280	330	330	250	280	330
				1.5	50	60	100	200	300	360	410	510	560			
			2.5	0.2	60	90	130	130	180	250	200	250	330	200	280	330
				0.7	50	80	130	180	200	280	280	330	380	250	300	330
				1.5	50	80	130	180	230	370	330	460	530	300	430	530
			4	0.2	60	90	140	130	150	200	200	250	330	200	250	330
				0.7	60	90	140	150	180	240	250	330	410	280	330	380
				1.5	50	80	110	150	200	250	300	460	560	330	460	530
1/8	SAM-04-03	FCS 04 & ACS 03	0.7	0.2	60	90	130	230	330	480						
				0.7	50	80	110	150	360	410	460	610	740			
				1.5	60	90	140	230	330	480						
			2	0.2	60	80	130	100	130	180	280	380	460	300	380	460
				0.7	60	90	130	130	180	230	330	430	560	200	530	660
				1.5	60	90	140	130	150	230	330	510	610	180	560	690
			2.5	0.2	60	80	130	90	110	160	230	300	360	280	330	460
				0.7	60	90	130	100	130	180	250	360	460	130	460	560
				1.5	60	90	130	100	140	200	280	380	530	150	510	630
			4	0.2	60	90	130	80	100	150	200	250	330	250	300	430
				0.7	60	90	110	80	100	150	200	280	360	280	380	460
				1.5	60	90	110	80	110	180	250	300	410	300	430	560
1/8	SAM-05-03	FCS 05 & ACS 03	0.7	0.2	80	100	150	230	300	460						
				0.7				200	280	380	610	740	890			
				1.5				230	300	380	530	710				
			2	0.2	60	90	150	100	150	200	300	380	480	300	380	480
				0.7	60	90	130	110	150	200	360	460	580	430	560	630
				1.5	50	80	130	110	150	230	380	480	690	460	580	690
			2.5	0.2	60	90	150	90	130	180	250	330	430	300	360	460
				0.7	60	90	140	100	150	200	300	410	510	380	460	560
				1.5	60	90	140	90	130	230	330	430	560	410	510	610
			4	0.2	60	90	150	60	100	180	230	280	360	250	300	430
				0.7	60	90	140	80	100	150	250	330	410	330	410	510
				1.5	60	90	140	80	100	150	230	330	430	300	430	580
1/8	SAM-06-04	FCS 06 & ACS 04	0.7	0.2	80	100	130	180	250	330	530	660	840			
				0.7				430	560	760	560	690	860			
				1.5												
			2	0.2	80	100	130	100	150	200	300	360	530	380	480	560
				0.7	60	90	130	100	150	220	330	410	560	410	530	580
				1.5							280	410	530	460	460	610
			2.5	0.2	80	100	140	40	130	180	250	300	430	300	430	530
				0.7	60	90	130	100	130	180	280	360	510	360	460	640
				1.5	60	90	130	80	130	200	230	330	430	330	460	660
			4	0.2	80	100	150	80	100	150	200	250	330	250	330	460
				0.7	80	100	130	90	110	180	230	300	410	300	410	530
				1.5	80	90	130	80	100	140	200	250	380	300	410	530
1/8	SAM-07-05	FCS 07 & ACS 05	0.7	0.2	80	100	130	200	280	380						
				0.7							530	690	890			
				1.5							480	610	840			
			2	0.2	80	100	130	130	160	230	330	460	580	430	630	690
				0.7				150	180	250	330	430	560	460	560	740
				1.5							360	430	610			
			2.5	0.2	80	100	140	140	150	230	280	380	480	430	610	760
				0.7	80	90	130	110	180	190	300	380	510	410	510	740
				1.5							300	360	530	360	480	690
			4	0.2	80	100	150	100	150	200	230	300	410	360	430	530
				0.7	80	100	160	130	160	190	250	330	430	330	430	580
				1.5	60	80	130	90	110	150	180	360	380	310	410	610

AIR ATOMIZING

CALL 413-772-0846  
Call for the name of your nearest BETE representative.

Spray angle performance varies with pressure. Contact BETE for specific data on critical applications.

# SpiralAir®

## High-flow Air Atomizing

### DESIGN FEATURES

- A two-fluid nozzle using any gas as the atomizing fluid
- Three-stage atomization for highest performance
- Designed for high reliability in extremely hostile environments
- Efficient design reduces compressed air consumption

### SPRAY CHARACTERISTICS

- Spray patterns:** Full Cone and Flat Fan  
**Spray angles:** 20° to 90°  
 (Other angles available by special order)  
**Flow rates:** 2.0 to 80 L/min



1 1/2" SA (Set-up #) - A - 00

AIR ATOMIZING

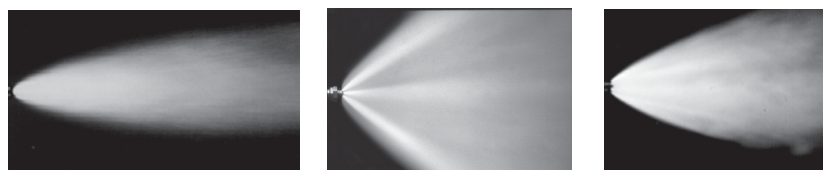

Narrow Round 20°

Wide Round 90°

Flat Fan 60°

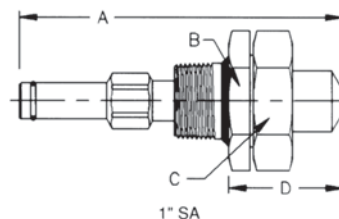

1 SA (Set-up #) - A -00

Dimensions are approximate. Check with BETE for critical dimension applications.

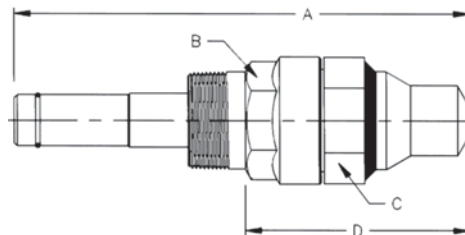

1 1/2" SA (Set-up #) - A -00

### SpiralAir Spray Set-up, Spiral Tip and Dimensions

Pipe Size	Spray Set-up Number	Spiral Tip No.	Spray Angle	Approx. Spray Type	Free Pass. Dia. (mm)	Pipe Size	Dimensions (mm)				Wt. (Kg)						
							A	B	C	D							
1"	SA 101	14	20°	Narrow Round	4.83	1	148	50.8	50.8	50.8	0.64						
	SA 308		90°	Wide Round	2.74												
	SA 310		60°	Wide Round	2.74												
	SA 402	20	90°	Flat Fan	4.22												
	SA 404		60°	Flat Fan	4.22												
	SA 103	20	20°	Narrow Round	7.14							1	148	50.8	50.8	50.8	0.64
	SA 307		90°	Wide Round	3.48												
	SA 309		60°	Wide Round	3.48												
SA 401	90°		Flat Fan	5.21													
SA 403	60°		Flat Fan	5.21													
SA 2100	28		20°	Narrow Round	9.27	1 1/2	229	50.8	55.6	113	1.5						
SA 2300		90°	Wide Round	5.41													
SA 2301		60°	Wide Round	5.41													

Larger sizes and flow rates available upon request.

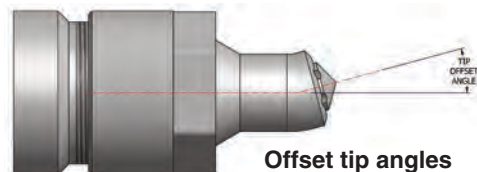
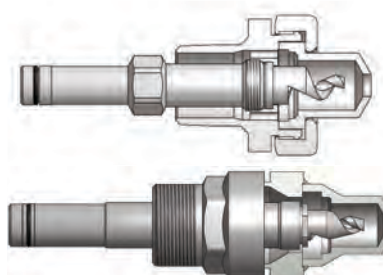

Offset tip angles available upon request

Standard Materials: 316 Stainless Steel with optional Cobalt Alloy 6 wear components.

Spray angle performance varies with pressure. Contact BETE for specific data on critical applications.

TO ORDER: specify pipe size, spray set-up #, hardware and material.

The SpiralAir can be configured to fit any installation requirement. The examples shown are just a few of the custom assemblies available. For more information, contact BETE Applications Engineering.

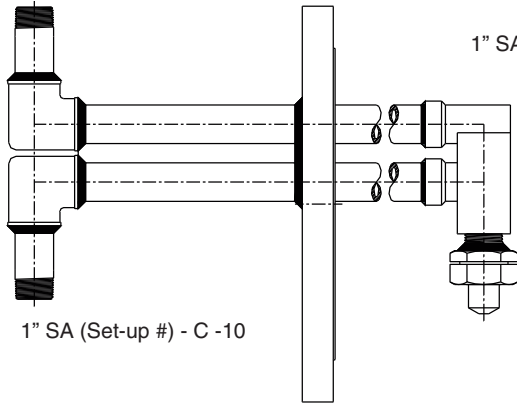
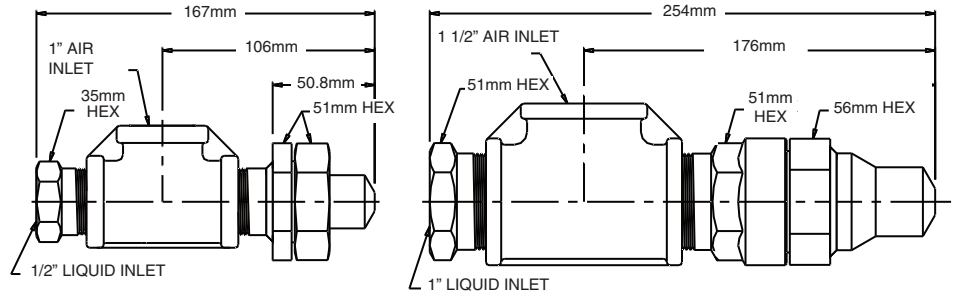

1" SA (Set-up #) - B - 00

1 1/2" SA (Set-up #) - B - 00

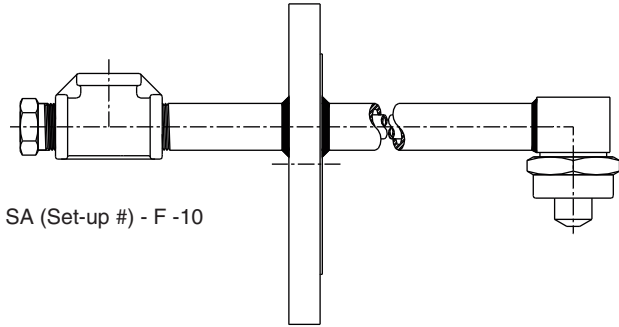

1" SA (Set-up #) - F - 10

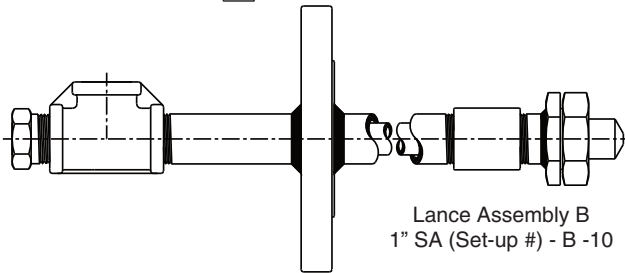

Lance Assembly B  
1" SA (Set-up #) - B - 10

Since very small variations in liquid pressure produce large variations in liquid flow, BETE recommends using a metering pump or other flow metering device to control the liquid flow.

**SpiralAir Set-Up Flow Rates**

Narrow, Wide and Flat Fan Patterns 1" and 1 1/2" BSP or NPT

BSP NPT	Spiral Tip Rating	2.0 bar air			3.0 bar air			4.0 bar air			5.0 bar air			6.0 bar air			7.0 bar air		
		liquid (l/min)	liquid (bar)	air (Nm <sup>3</sup> /h)	liquid (l/min)	liquid (bar)	air (Nm <sup>3</sup> /h)	liquid (l/min)	liquid (bar)	air (Nm <sup>3</sup> /h)	liquid (l/min)	liquid (bar)	air (Nm <sup>3</sup> /h)	liquid (l/min)	liquid (bar)	air (Nm <sup>3</sup> /h)	liquid (l/min)	liquid (bar)	air (Nm <sup>3</sup> /h)
1"	14	2	1.8	47.1	2	2.7	77.9	2	3.7	110.3	2	4.7	144.0	2	5.9	179.2	2	7.1	215.8
		3	1.9	36.1	3	2.8	59.8	3	3.8	84.6	3	4.8	110.5	3	6.0	137.5	3	7.2	165.7
		4	2.0	29.9	4	2.9	49.6	4	3.9	70.1	4	4.9	91.6	4	6.1	114.0	4	7.3	137.3
		5	2.1	25.8	5	3.0	42.8	5	4.0	60.6	5	5.0	79.2	5	6.2	98.6	5	7.4	118.7
		6	2.1	22.9	6	3.1	38.0	6	4.1	53.8	6	5.1	70.3	6	6.3	87.5	6	7.5	105.4
		7	2.2	20.7	7	3.1	34.4	7	4.1	48.7	7	5.2	63.6	7	6.4	79.1	7	7.6	95.3
		8	2.3	19.0	8	3.2	31.5	8	4.2	44.6	8	5.3	58.3	8	6.5	72.5	8	7.7	87.4
		9	2.3	17.6	9	3.3	29.2	9	4.3	41.3	9	5.4	54.0	9	6.5	67.2	9	7.8	80.9
		10	2.4	16.4	10	3.3	27.2	10	4.3	38.5	10	5.4	50.4	10	6.6	62.7	10	7.9	75.5
		11	2.4	15.4	11	3.4	25.6	11	4.4	36.2	11	5.5	47.3	11	6.7	58.9	11	7.9	71.0
		12	2.4	14.6	12	3.4	24.2	12	4.4	34.2	12	5.6	44.7	12	6.8	55.7	12	8.0	67.1
		20	4	1.8	61.9	4	2.6	94.4	4	3.4	127.2	4	4.3	160.3	4	5.2	193.7	4	6.2
	8		2.0	43.0	8	2.7	65.4	8	3.6	88.1	8	4.5	111.0	8	5.4	134.1	8	6.4	157.5
	11		2.1	36.4	11	2.9	55.3	11	3.7	74.4	11	4.6	93.8	11	5.6	113.3	11	6.6	133.0
	15		2.2	30.9	15	3.0	46.9	15	3.8	63.2	15	4.8	79.5	15	5.7	96.1	15	6.7	112.8
	19		2.3	27.3	19	3.1	41.4	19	4.0	55.7	19	4.9	70.2	19	5.9	84.8	19	6.9	99.5
	23		2.4	24.7	23	3.2	37.5	23	4.1	50.4	23	5.0	63.4	23	6.0	76.6	23	7.0	89.9
	28	26	2.5	23.1	26	3.3	35.1	26	4.2	47.2	26	5.1	59.4	26	6.1	71.8	26	7.1	84.2
30		2.5	21.5	30	3.4	32.6	30	4.2	43.8	30	5.2	55.1	30	6.1	66.5	30	7.2	78.1	
34		2.6	20.1	34	3.4	30.5	34	4.3	41.0	34	5.2	51.5	34	6.2	62.2	34	7.2	73.1	
38		2.6	19.0	38	3.5	28.7	38	4.4	38.6	38	5.3	48.6	38	6.3	58.7	38	7.3	68.9	
1 1/2"		28	40	3.4	67.2	40	4.3	104.7	40	5.3	147.2	40	6.3	194.6	40	7.4	247.0		
			45	3.5	61.3	45	4.4	95.6	45	5.4	134.4	45	6.4	177.7	45	7.5	225.5		
	50		3.5	56.5	50	4.4	88.2	50	5.4	123.9	50	6.5	163.8	50	7.6	207.9			
	55		3.6	52.5	55	4.5	81.9	55	5.5	115.2	55	6.5	152.2	55	7.6	193.1			
	60		3.6	49.0	60	4.6	76.6	60	5.6	107.7	60	6.6	142.3	60	7.7	180.5			
	65		3.7	46.1	65	4.6	72.0	65	5.6	101.3	65	6.7	133.8	65	7.8	169.7			
	70		3.7	43.5	70	4.7	68.0	70	5.7	95.6	70	6.7	126.4	70	7.8	160.2			
	75		3.8	41.2	75	4.7	64.5	75	5.7	90.7	75	6.8	119.8	75	7.9	151.9			
80	3.8	39.2	80	4.7	61.4	80	5.7	86.3	80	6.8	114.0	80	8.0	144.5					

Standard Materials: 316 Stainless Steel with optional Cobalt Alloy 6 wear components

Spray angle performance varies with pressure. Contact BETE for specific data on critical applications.



# CHOOSING A TANK WASHING NOZZLE

Adequate coverage and effective scrubbing are of prime importance in equipment and tank washing. When selecting BETE nozzles, you should consider the following vessel characteristics and nozzle design criteria: size and shape of the vessel, internals, vessel opening, type of residue to remove, and spray coverage.

## Size and Shape of the Vessel to Clean

BETE's tank washing nozzles can be used to clean, wash, and rinse every size vessel from small bottles to a wide variety of process tanks and railroad tankers.

The HydroWhirl® S and TW series offer the best options for cleaning small bottles, kegs, and barrels due to their compact design.

The free passage of the HydroClaw® is an ideal solution for small tanks up to 3m where clogging can lead to downtime. Medium-sized tanks up to 6m are best cleaned using the HydroWhirl® S, or the residue-resistant HydroWhirl® Poseidon® up to 7.6m.

Where higher impact for hard to clean residues or coverage distance for large tanks is needed, BETE's tank washing machines, the HydroWhirl® Orbitor 100 and HydroWhirl® Orbitor, are an excellent choice.

Tank Washing Nozzle	up to	Coverage Distance in Meters (Diameter)												
		2	3	4	5	7	9	12	16	18	20	25+		
HydroClaw	3.0 m													
TW 1	3.6 m													
HydroWhirl S	6.0 m													
HydroWhirl Poseidon	7.6 m													
HydroWhirl Orbitor 100	17 m													
HydroWhirl Orbitor	40 m													up to 40 m



### What is ATEX (Ex)?

ATEX is an acronym that stands for 'ATmosphere EXplosible'. BETE products are reviewed and approved under ATEX Directive 2014/34/EU concerning equipment and protective systems intended for use in potentially explosive atmospheres.

**All HydroWhirl Orbitor, HydroWhirl Orbitor 100, and HydroWhirl S nozzles are available with ATEX approval.**

# HydroWhirl® S

## Tank Washing - Slotted Spray Nozzle

### DESIGN FEATURES

- Cleans more quickly, and uses less spray media and lower pressure than static tank washers
- Surface finish of 0.8 µm (microns) R<sub>a</sub> or better: ideal for sanitary applications
- Laser-welded design for durability
- Stainless steel construction - corrosion-resistant material
- Three connections: threaded, clip-on, and welded
- Made from FDA compliant materials for use in Clean-In-Place (CIP) applications.

### SPRAY CHARACTERISTICS

- Self-cleaning bearings
- Vigorous moving spray action
- Spray Angles: 360°, 90° Down\*, 180° Up\*, 180° Down, 270° Up, 270° Down, \*Not available in all flow rates

**Flow rates:** 4.39 – 338 L/min

All HydroWhirl S nozzles are available with ATEX approval for Zone 0



### STANDARD CONNECTION SIZES

Additional connection sizes available on request

Connection Type	Nozzle Number														
	HWS-20-3 HWS-20-4 HWS-20		HWS-30-5 HWS-30-6 HWS-30		HWS-40-7.5 HWS-40-8 HWS-40-9 HWS-40			HWS-40HF-11 HWS-40HF		HWS-50-16 HWS-50					
FNPT/G	-	-	1/4"	-	-	1/2"	-	1/2"	-	-	1"	-	-		
Pipe Clip On	1/8"	-	-	3/8"	-	-	3/4"	-	-	3/4"	-	-	1-1/4"	1-1/2"	-
Pipe Weld	-	1/4"	1/4"	-	1/2"	1/2"	-	1"	1/2"	-	1"	1"	-	-	2"
Dim F (mm)	10.3	13.7	13.7	17.1	21.3	21.3	26.7	33.5	21.3	26.7	33.5	33.4	42.2	48.3	60.3
Tube Clip On	-	-	-	-	-	-	-	-	-	-	-	-	-	-	-
Tube Weld	3/8"	1/2"	3/8"	1/2"	3/4"	3/4"	1"	3/4"	1"	1"	1"	1"	1-1/4"	1-1/2"	2"
Dim F (mm)	9.5	12.7	9.7	12.7	19.1	19.1	25.4	19.1	25.4	25.4	25.4	31.8	38.1	50.8	
DIN Clip On**	DN8	-	-	DN15	-	DN15	DN20	DN25	-	DN15	DN20	DN25	DN40	DN50	
DIN Weld**	-	DN10	DN10	-	DN15	DN15	DN20	DN25	DN15	DN20	DN25	DN40	DN50		
Dim F (mm)	10	13	13	19	19	23	29	19	23	29	41	53			

Optimal cleaning performance achieved between 2-3.5 bar; maximum operating pressure is 10 bar.

### HydroWhirl S Flow Rates and Dimensions

Nozzle Number	LITERS PER MINUTE @BAR						Dimensions (mm)					Wt. (g)	Coverage Diameter (m) @2.75 bar
	0.5 bar	0.7 bar	1 bar	2 bar	3 bar	4 bar	A	B (NPT) B (G)	C	D MAX	E		
HWS-20-3	4.39	4.79	5.40	7.05	8.19	9.11	16.7	42.7	69.1	3.81	2.18	24.9	1.5
HWS-20-4	7.41	8.10	9.20	12.2	14.2	15.9		49.8					
HWS-20	10.8	12.0	13.9	20.2	25.3	29.1							
HWS-30-5	7.71	8.80	10.4	15.3	18.9	21.9	27.9	60.3	83.3	5.33	2.18	93.0	2.4
HWS-30-6	19.5	21.0	23.4	29.8	34.2	37.6		66.5					
HWS-30	19.1	21.7	25.7	37.0	45.4	53.1							
HWS-40-7.5	18.8	21.3	25.1	35.7	43.8	50.7	38.9	92.7	108	8.89	3.96	306	3.4
HWS-40-8	21.5	24.3	28.6	40.6	49.6	57.2		100					
HWS-40-9	26.6	30.2	35.7	51.5	63.0	72.7							
HWS-40	30.2	34.6	41.2	59.9	71.8	82.5							
HWS-40HF-11	40.9	46.4	54.5	77.3	95.0	109	38.9	92.7	108	8.89	3.96	302	4.0
HWS-40HF	50.4	57.3	67.5	97.0	116	132		100					
HWS-50-16	81.6	92.0	108	154	188	218	69.1	158	180	8.89	5.56	1524	5.5
HWS-50	125	142	167	238	293	338		164					

Standard Materials: Nozzle: 316L Stainless Steel; Ball Bearings: 316 Stainless Steel

\*Flow rates represent threaded connections with a 360° spray angle. Flow rates may vary for other connection types and spray angles, please contact BETE for more information.

\*\*Per DIN 11866 Part A / DIN 11850 Part B

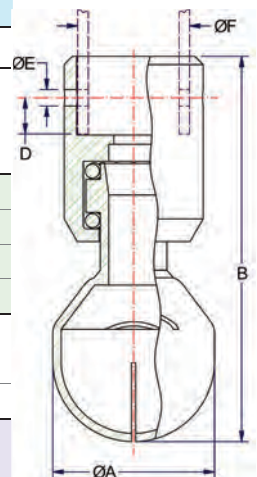

Threaded and Clip On Connections

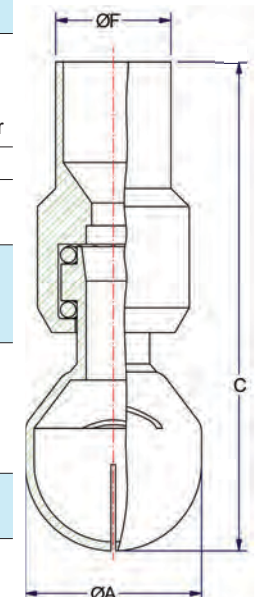

Weld On Connections

TANK WASHING

CALL 413-772-0846  
Call for the name of your nearest BETE representative.

# HydroWhirl® Poseidon®



## Tank Washing - PTFE Spray Nozzle

### DESIGN FEATURES

- Cleans more quickly and uses less water and lower pressure than static tank washers
- PTFE construction:
  - Ideal for harsh chemical environments
  - Corrosion resistant
- Available in threaded, pipe, tube, or DIN clip-on connections
- Made from FDA compliant materials for use in Clean-In-Place (CIP) applications.

### SPRAY CHARACTERISTICS

- Slow spinning produces longer spray dwell time on the target surface, increasing impact over conventional rotating designs
- Complete 360° omnidirectional spray pattern, other spray angles available upon request

**Flow rates:** 14.3 to 307 L/min

TANK WASHING

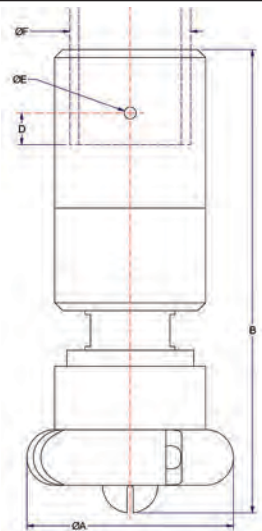

### STANDARD CONNECTION SIZES

Connection Type	Nozzle Number											
	HWP-10			HWP-23 HWP-28			HWP-32 HWP-37			HWP-48 HWP-55 HWP-65 HWP-73		
FNPT/BSP	1/4"	3/8"	1/2"	3/8"	1/2"	3/4"	1/2"	3/4"	1"	1"	1-1/4"	1-1/2"
Pipe Clip-On							X					
Dim F (mm)	13.7	17.3	21.3	17.3	21.3	26.7	21.3	26.7	33.5	33.5	42.2	48.3
Tube Clip-On	1/2"	3/4"	3/4"	3/4"	1"	1"	1"	1-1/4"	1-1/4"	1-1/2"	1-3/4"	1-3/4"
Dim F (mm)	12.7	19.1	19.1	19.1	25.4	25.4	25.4	31.8	31.8	38.1	44.5	44.5
DIN Clip On**	DN10	DN15	DN15	DN15	DN20	DN20	DN20	DN25	DN25	DN25	DN40	DN40
Dim F (mm)	13	19	19	19	23	23	23	29	29	29	41	41

### HydroWhirl Poseidon Nozzle Flow Rates\* and Dimensions

Nozzle Number	Spray Angle	LITERS PER MINUTE @BAR						Dimensions (mm)				Mass (g)	Coverage Diameter (m) @2.8 bar
		0.5 bar	1 bar	1.5 bar	2 bar	3 bar	4 bar	A	B	D MAX	E		
HWP-10	360°	14.3	20.3	24.9	28.8	35.4	40.9	42.7	100.1	12.7	2.4	85.0	2.7
HWP-23		30.3	43.1	52.9	61.2	75.2	87.0	49.5	104.6	12.7	4.1	113	3.4
HWP-28		34.6	49.0	60.0	69.3	84.9	98.0	49.5	104.6	12.7	4.1	113	4.3
HWP-32		37.5	53.8	66.5	77.2	95.4	111	76.2	162.6	12.7	4.8	595	4.3
HWP-37		48.5	69.2	85.2	98.7	122	141	76.2	162.6	12.7	4.8	595	4.9
HWP-48		66.0	94.0	116	134	165	191	83.8	185.4	12.7	4.8	822	7.3
HWP-55		75.4	107	132	153	188	218						7.3
HWP-65		98.7	140	171	198	243	281						7.6
HWP-73		108	153	187	216	265	307						

Standard Materials: Nozzle: PTFE; Retaining Clip: 316 stainless steel

\*Flow rates represent threaded connections with a 360° spray angle. Flow rates may vary for other connection types and spray angles, please contact BETE for more information.

\*\*Per DIN 11866 Part A / DIN 11850 Part B

[www.BETE.com](http://www.BETE.com)

TO ORDER: specify pipe size, connection type, nozzle number, spray angle, and material.



# HydroWhirl® Orbitor

## High Impact Rotary Tank Cleaning Machine

### DESIGN FEATURES

- Easily field-serviced to reduce maintenance costs
- Minimum moving parts to extend operating life
- Self-cleaning; self-lubricating
- High-impact jets; orbital wash pattern = high efficiency cleaning process
- Compact design
- 2 or 4 nozzle configurations = wash pattern variable up to super intense
- Male or female connections

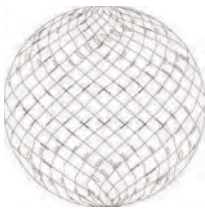

Orbitor 2 nozzle spray pattern

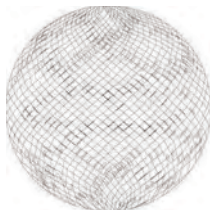

Orbitor 4 nozzle spray pattern

### SPRAY CHARACTERISTICS

- 360° wash pattern.
- 180° patterns available on request

- Variable cycle times
- High impact cleaning

**Flow rates:** 80 - 600 L/min

**Working Pressure:** 3 - 10 bar

### Materials:

Housing and Nozzle Head: 316L

Gears: PEEK + 316 SS

Bushings/Seals: Carbon Filled PTFE

**Max. Working Temp.:** 95 °C

**Max. Ambient Temp.:** 140 °C

**Weight:** 7.5 kg

Minimum opening size is 5" for either 2-nozzle or 4-nozzle standard-capacity model with jets vertically aligned.



All HydroWhirl Orbitor tank cleaning machines are available with ATEX approval.

Jet lengths are effective cleaning lengths

# Nozzles X Orifice Size	4 x 4.2 mm			4 x 5 mm			4 x 6 mm			4 x 7 mm			4 x 8 mm		
	Flow (L/min)	Jet Length (m)	Cycle Time (min)	Flow (L/min)	Jet Length (m)	Cycle Time (min)	Flow (L/min)	Jet Length (m)	Cycle Time (min)	Flow (L/min)	Jet Length (m)	Cycle Time (min)	Flow (L/min)	Jet Length (m)	Cycle Time (min)
Connection Size	1" and 1-1/2"			1" and 1-1/2"			1-1/2"			1-1/2"			1-1/2"		
Pressure (BAR)	80.0	2.9	11	112	4	13	138	5.3	15.5	217	6.5	11.4	250	7.2	15.5
3	100	3	9.3	137	4.2	10.8	170	5.7	12.9	252	7.1	9.8	293	8	12.9
4	115	3.5	7.9	155	4.7	9.4	200	6.2	11	283	7.7	8.7	333	9	11
5	127	4	6.9	173	5.2	8	220	7	9.5	310	8.5	8.1	367	9.9	9.5
6	138	5	6.3	185	6.3	7.3	240	8	8.4	333	9.4	7.5	395	10.6	8.5
7	147	6.2	5.8	195	7.5	6.8	257	9.4	7.6	350	10.3	7.1	418	11.2	7.8
8	153	7.1	5.6	202	8.5	6.5	270	10.3	7	367	11.2	6.9	438	12.2	7
9	157	7.8	5.5	207	9	6.4	282	11.2	6.9	380	12	6.6	458	13	6.9
10	2 x 6 mm			2 x 7 mm			2 x 8 mm			*2 x 10 mm			*2 x 12.5 mm		
Connection Size	1-1/2"			1-1/2"			1-1/2"			1-1/2"			1-1/2"		
Pressure (BAR)	80.0	5.5	33	93.3	6.5	37.5	117	7.2	25.7	217	9.8	41	330	10.1	26.8
3	91.7	6	27.2	117	7.2	31.6	150	8	22.9	255	10.5	34.2	383	11.2	24
4	108	6.3	24.7	137	7.9	28.2	172	8.7	20.5	290	11.5	30.5	433	12.1	21.7
5	122	7	22.6	153	8.5	25.8	190	9.4	18.9	320	12.7	28	473	13.4	19.8
6	130	8	21	168	9.2	24	203	10.3	17.5	347	13.9	26	512	14.8	18.4
7	140	9	19.5	182	10.4	22.3	213	11.3	16.4	368	15.2	24.5	547	16.4	17.2
8	148	10.2	18.4	192	11.3	21	223	12.4	15.6	390	17	23.2	572	18.3	16.3
9	157	11.5	17.4	200	12.3	20	232	13.5	14.9	405	18.8	22	600	20.1	15.5
10															

TANK WASHING

CALL 413-772-0846  
Call for the name of your nearest BETE representative.



# HydroWhirl® Orbitor 100

## High Impact Rotary Tank Cleaning Machine

### DESIGN FEATURES

- Easily field-serviced to reduce maintenance costs
- Minimum moving parts to extend operating life
- Self-cleaning; self-lubricating
- High-impact jets; orbital wash pattern = high efficiency cleaning process
- Ideal for small to medium tanks, easily fits through Ø100 mm (4") openings or Ø85 mm (3.35") when nozzle head is vertically aligned
- 4 nozzle configurations
- Female connections

### SPRAY CHARACTERISTICS

- 360° wash pattern
  - Variable cycle times
  - High impact cleaning
- Flow rates:** 44.8 - 198 L/min  
**Working Pressure:** 3 - 10 bar

### Materials:

Housing and Nozzle Head: 316L  
 Gears: PEEK + 316 SS  
 Bushings/Seals: Carbon Filled PTFE

**Max. Working Temp.:** 95 °C (200 °F)  
**Max. Ambient Temp.:** 140 °C (285 °F)  
**Weight:** 2.5 kg



TANK WASHING

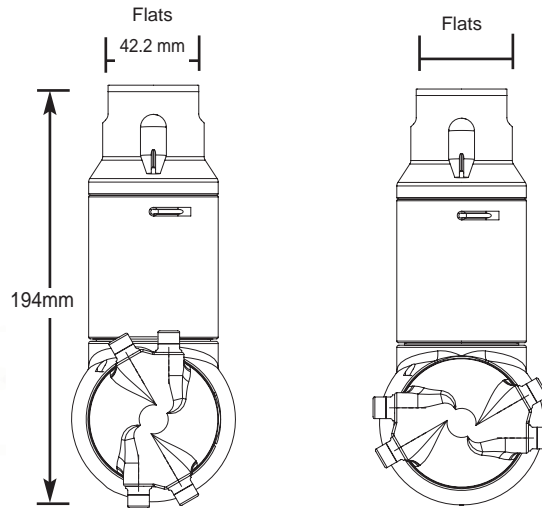

Vertical Nozzle Head Alignment  
 Clearance Diameter: 85 mm

Horizontal Nozzle Head Alignment  
 Clearance Diameter: 100 mm



All HydroWhirl Orbitor 100 tank cleaning machines are available with ATEX approval

*Performance may vary with ATEX models.*

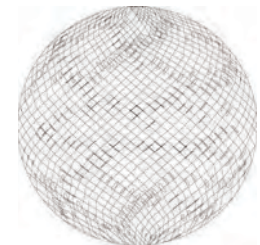

4 nozzle spray pattern

### Jet lengths are effective cleaning lengths

# Nozzles X Orifice Size	4 x 3 mm			4 x 4 mm			4 x 5 mm			4 x 6 mm		
	Flow (L/min)	Jet Length (m)	Cycle Time (min)	Flow (L/min)	Jet Length (m)	Cycle Time (min)	Flow (L/min)	Jet Length (m)	Cycle Time (min)	Flow (L/min)	Jet Length (m)	Cycle Time (min)
3	45.0	1.0	6.0	66.7	2.0	5.5	88.3	2.5	4.5	115	3.0	4.0
4	51.7	1.5	5.5	75.0	2.5	4.8	100	3.0	4.0	127	3.5	3.5
5	58.3	2.0	5.0	85.0	3.0	4.3	110	3.5	3.5	138	4.0	3.0
6	65.0	2.0	4.4	93.3	3.0	3.8	120	3.5	3.0	152	4.0	2.7
7	71.7	2.5	4.0	102	3.5	3.3	130	4.0	2.8	163	4.5	2.4
8	78.3	2.5	3.5	110	3.5	2.9	140	4.0	2.5	175	4.5	2.1
9	85.0	3.0	3.1	118	4.0	2.6	148	4.5	2.1	187	5.0	1.8
10	90.0	3.5	3.0	127	4.0	2.5	157	4.5	2.0	198	5.0	1.8

TO ORDER: specify pipe size, connection type, nozzle number, spray angle, and material.

# HydroClaw<sup>®</sup>

## Tank Washing - Superior Clog Resistance

### DESIGN FEATURES

- Patent-pending, clog-resistant design with no moving parts
- Allows passage of particles 6.4 mm in diameter, three times the free passage of a comparable spray ball
- Made from FDA compliant 316L stainless steel for use in food-grade and sanitary Clean-In-Place (CIP) applications
- Low pressure/high flow operation quickly cleans tank walls to reduce overall water consumption compared to a static spray ball
- Self-draining and self-flushing
- Laser-welded for durability
- Available in a variety of connection sizes and types, including threaded, clip-on and welded.
- Clip-on nozzles include low-profile retaining pin for secure connection
- Fits through compact openings: either 63.5 mm or 76 mm diameter

### SPRAY CHARACTERISTICS

- Vigorous rinsing action quickly flushes solids and contamination from vessels
- Complete 360° omnidirectional coverage
- Optimum cleaning performance at 2 bar
- Recommended installation 0.6 - 1.0 m vertically below top of tank

**Flow rates:** 119 - 442 L/min

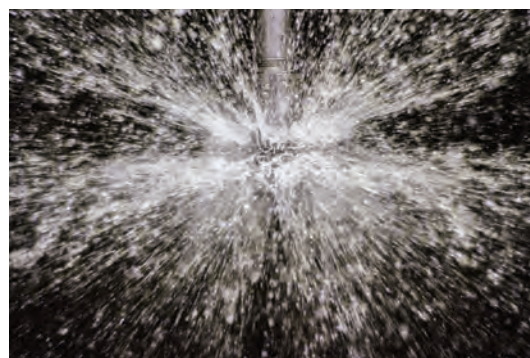
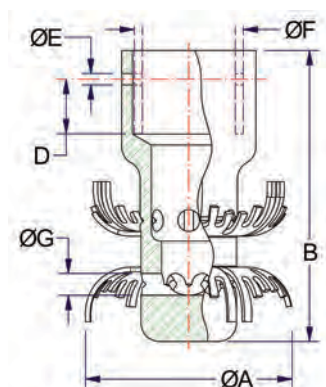

TANK WASHING

CALL 413-772-0846  
Call for the name of your nearest BETE representative.

HydroClaw Flow Rates and Dimensions													
Connection Types	Nozzle Number	LITERS PER MINUTE @BAR				Dimensions (mm)						Wt (g)	Coverage Diameter (m) @2 BAR
		1.5 BAR	2 BAR	2.5 BAR	3 BAR	A	B	D	E	F	Free Pass. G		
3/4" NPT	HC-42	119	136	152	166	60.5	91.2	-	-	-	6.4	416	2.4
G3/4												413	
1" Tube Weld-On												325	
1-1/2" Tube Clip-On	HC-42	125	145	161	176	60.5	102	19.1	4.1	-	6.4	504	2.4
1" Tube Clip-On							391						
DN20 Tube Clip-On*							416						
3/4" Pipe Clip-On							382						
1" NPT	HC-100	279	322	360	394	73.2	102	-	-	-	7.6	649	3.0
G1												635	
1-1/2" Tube Weld-On												425	
1-1/2" Tube Clip-On	HC-100	312	361	403	442	73.2	102	19.1	4.1	-	7.6	527	3.0
DN40 Tube Clip-On*												437	
1" Pipe Clip-On												598	

**Standard Material: 316L Stainless Steel**

Clip-on flow rates may vary depending on actual O.D. of installation tube or pipe

\*Per DIN 11866 Part A / DIN 11850 Part B

# TW

## Tank Washing

### DESIGN FEATURES

- Clog-resistant spiral design
- Energy efficient
- Compact design; fits small openings

### SPRAY CHARACTERISTICS

- Easy to maintain
- Unique patterns that spray in opposing directions

**Flow rates:** 11.4 to 260 l/min

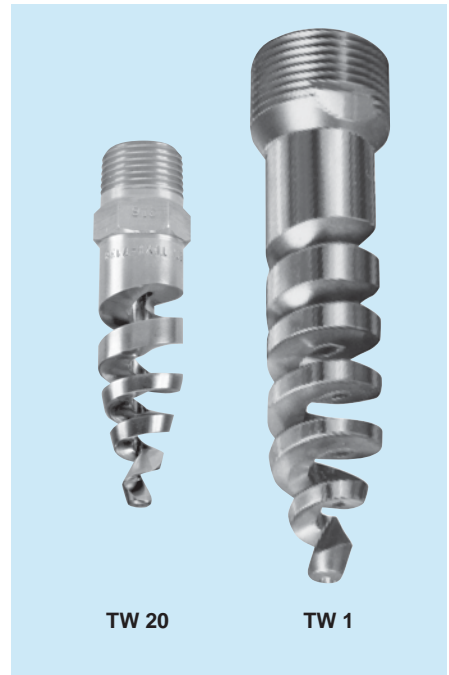

TW 20

TW 1

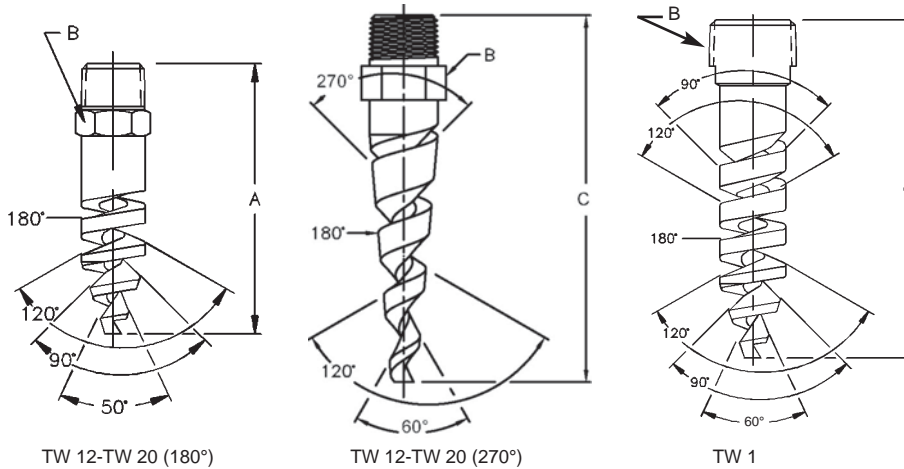

TW 12-TW 20 (180°)

TW 12-TW 20 (270°)

TW 1

Dimensions are approximate. Check with BETE for critical dimension applications.

### Tank Washing TW Coverage Chart

When spraying at 2 - 3 bar

Pipe Size	Nozzle Number	Scrubbing Diameter (mm)	Rinsing Diameter (mm)
3/8	TW12	380	760
	TW14	460	1200
	TW16	610	1500
	TW20	910	2100
1/2	TW24	1200	2700

Dimensions are approximate. Check with BETE for critical dimension applications.

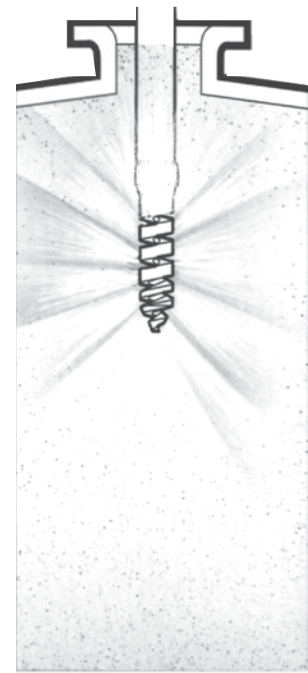

### Tank Washing TW Flow Rates and Dimensions

TW 180° and 270°, 3/8", 1/2", and 1" Pipe Sizes

Male Pipe Size	Nozzle Number	Available Spray Angles	K Factor	LITERS PER MINUTE					Approx. (mm)		Metal Only Dim. (mm)			Weight (g) Metal	
				0.7 bar	1 bar	2 bar	3 bar	4 bar	5 bar	Orifice Dia	Free Pass. Dia.	A	B		C
3/8	TW12	180°, 270°	13.7	11.4	13.7	19.3	23.7	27.3	30.6	4.83	3.30	73.0	17.5	92.1	49.6
	TW14	180°, 270°	18.5	15.4	18.5	26.1	32.0	36.9	41.3	5.59	3.30				
	TW16	180°, 270°	24.2	20.2	24.2	34.2	41.8	48.3	54.0	6.35	3.30				
	TW20	180°, 270°	37.6	31.5	37.6	53.2	65.1	75.2	84.1	7.87	3.30				
1/2	TW24	270°	54.9	46.0	54.9	77.7	95.1	110	123	10.4	4.32		22.2	108.0	181
1	TW1	270°	116	97.2	116	164	201	232	260	14.2	5.08		28.7	146.1	298

$$\text{Flow Rate (l/min)} = K \sqrt{\text{bar}}$$

Spray angle performance varies with pressure. Contact BETE for specific data on critical applications.

# CLUMP

## Tank Washing Nozzles

### DESIGN FEATURES

- Each nozzle in the stationary cluster is a BETE clog-resistant full cone nozzle of the MaxiPass® series
- Can be supplied with various other BETE nozzles for any desired application
- Female connection

### SPRAY CHARACTERISTICS

- Spherical omnidirectional coverage
- Six nozzles arranged in cluster to project spray in all directions

**Flow rates:** 28.1 to 290 l/min  
(Special flow rates available)

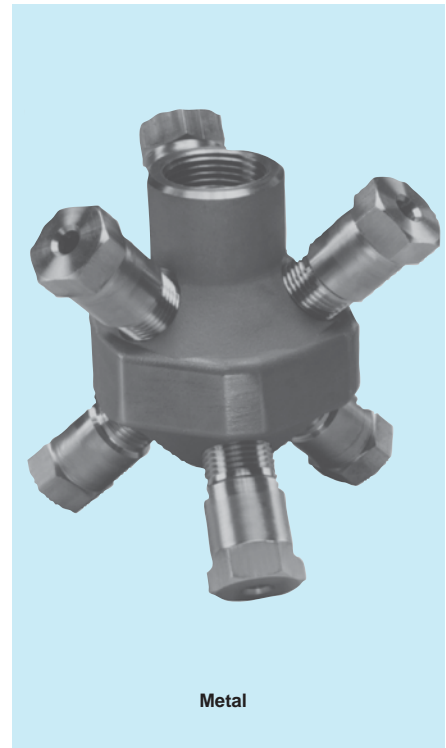

Metal

### CLUMP Coverage Chart When spraying at 3 bar

Female Pipe Size	Nozzle Number	Scrubbing Diameter (mm)	Rinsing Diameter (mm)
3/4"	CLUMP125	1200	2400
	CLUMP156	1200	3700
	CLUMP187	1800	4300
1"	CLUMP187	1800	4300
	CLUMP218	2400	4300
	CLUMP250	3000	4900

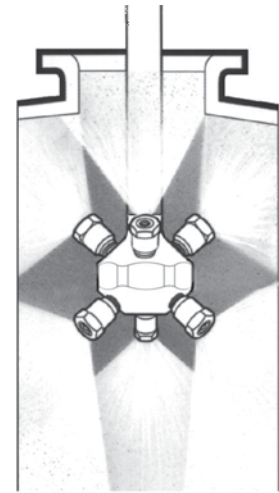
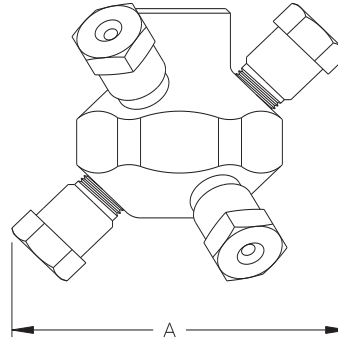

Typical CLUMP installation

Dimensions are approximate. Check with BETE for critical dimension applications.

### CLUMP Flow Rates and Dimensions

Spherical, 360° Spray Angle, 3/4" and 1" Pipe Size, BSP or NPT

Female Pipe Size	Nozzle Number	K Factor	LITERS PER MINUTE @ BAR						Minimum Entrance Opening (mm) A	Weight (kg)	
			0.7 bar	1 bar	2 bar	3 bar	4 bar	5 bar		Metal	Plas.
3/4"	CLUMP125	33.2	28.1	33.2	46.0	55.6	63.7	70.8	120	1.29	0.22
	CLUMP156	52.7	44.6	52.7	73.2	88.2	101	112			
	CLUMP187	76.2	65.7	76.2	106	128	146	163			
1"	CLUMP187	76.2	65.7	76.2	106	128	146	163	146	2.34	0.40
	CLUMP218	121	103	121	168	203	232	258			
	CLUMP250	136	115	136	188	228	261	290			

$$\text{Flow Rate (l/min)} = K (\text{bar})^{0.47}$$

**Standard Materials: 316 Stainless Steel.** Other materials available on request. 3/4" CLUMP not available in PTFE.

Spray angle performance varies with pressure. Contact BETE for specific data on critical applications.



# LEM

## Tank Washing Nozzle

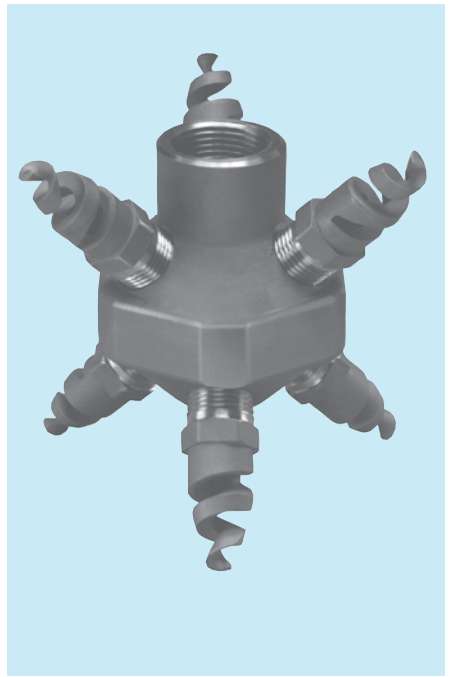

### DESIGN FEATURES

- Each nozzle in the stationary cluster is a BETE clog-resistant spiral nozzle of the TF Series
- Can be supplied with various other BETE nozzles for any desired application
- Female connection

### SPRAY CHARACTERISTICS

- Spherical omnidirectional coverage
  - Six nozzles arranged in cluster to project spray in all directions
- Flow rates:** 16.0 to 597 l/min  
(special flow rates available, special tips upon request)

TANK WASHING

### LEM Coverage Chart When Spraying at 3 - 4 BAR

Female Pipe Size	Nozzle Number	Scrubbing Diameter (mm)	Rinsing Diameter (mm)
3/4	LEM6	450	900
	LEM8	900	1800
	LEM10	1400	2700
1	LEM12	2000	4000
	LEM14	2100	4200
	LEM16	2200	4400
	LEM20	2400	4900

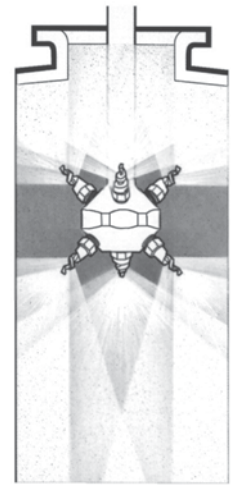
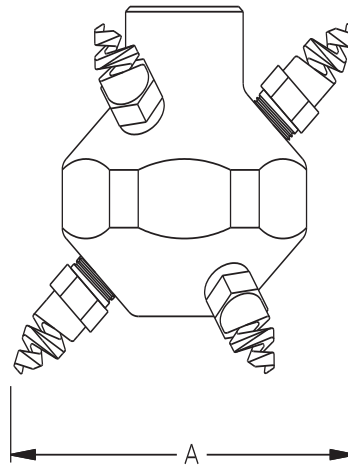

Typical LEM installation

Dimensions are approximate. Check with BETE for critical dimension applications.

### LEM Flow rates and dimensions

Spherical, 360° Spray Angle, 3/4" and 1" Pipe Sizes, BSP or NPT

Female Pipe Size	Nozzle Number	K Factor	LITERS PER MINUTE @ BAR								Minimum Entrance Open. (mm) A	Weight	
			0.7 bar	1 bar	1.5 bar	2 bar	3 bar	4 bar	5 bar	7 bar		(kg) Metal	(g) Plas.
3/4	LEM6	19.1	16.0	19.1	23.4	27.1	33.2	38.3	42.8	50.6	114	1.02	170
	LEM8	36.5	30.5	36.5	44.7	51.6	63.2	72.9	81.5	96.5			
	LEM10	57.0	47.7	57.0	69.8	80.6	98.7	114	127	151			
1	LEM12	82.0	68.6	82.0	100	116	142	164	183	217	133	1.87	312
	LEM14	111	92.7	111	136	157	192	222	248	293			
	LEM16	144	120	144	176	203	249	287	321	380			
	LEM20	226	189	226	276	319	391	451	504	597			

$$\text{Flow Rate (l/min)} = K \sqrt{\text{bar}}$$

Standard Materials: Brass, 316 Stainless Steel, PVC, and PTFE

Spray angle performance varies with pressure. Contact BETE for specific data on critical applications.

TO ORDER: specify pipe size, connection type, nozzle number, spray angle, and material.

# AFF

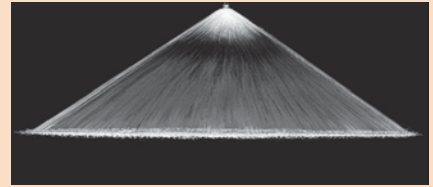

Fan 145°

## Fire Protection

### DESIGN FEATURES

- One-piece construction
- Clog-resistant
- Durable
- Male connection

All 1/2" connection AFF nozzles require a main line strainer designed to entrap material 1/8" and larger.

### SPRAY CHARACTERISTICS

- Extra-wide flat fan spray angle
- Medium-impact spray
- Spray discharge deflected 75° from inlet axis
- Coarse atomization

Spray pattern: Flat Fan

Flow rates: 25.3 - 263 L/min

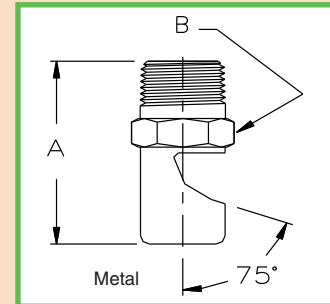

### AFF Flow Rates and Dimensions

Connection	Nozzle Number	K Factor	Pressure (bar)	Flow Rate (l/min)	Orifice (mm)	Free Passage (mm)	Dimensions (mm)		Mass (g)
							A	B	
1/2"	1.18-145	17	3.4	31.4	5.3	5.3	50.8	22.4	117
			10.3	54.6					
	1.66-145	23.9	3.4	44.1	6.4	6.4			
			10.3	76.7					
	2.53-145	36.5	3.4	67.3	7.9	7.9			
			10.3	117.1					
2.85-145	41	3.4	75.6	8.1	8.1				
		10.3	131.6						
3/4"	3.35-145	48.3	3.4	89.1	8.8	8.8	66.8	35.1	345
			10.3	155					
	4.43-145	63.9	3.4	118	10.3	10.3			
			10.3	205					
	5.69-145	82	3.4	151	11.5	11.5			
			10.3	263					

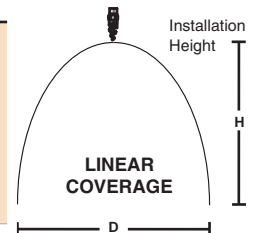

### AFF Spray Coverage Nozzle Spray Directed Vertically Down

Connection (Male Pipe Size)	Installation Height - H (m)			0.3	0.6	0.9	1.2	1.5	1.8	2.1	2.4	2.7	3
	Nozzle Number	Pressure (bar)	Measured Angle	Linear Coverage - D (m) @ Installation Height - H (m)									
1/2"	1.18-145	3.4	144°	1.88	3.28	4.33	5.28	5.94	6.32	6.67	6.95	7.10	7.21
		10.3	148°	2.07	3.56	4.45	5.28	5.88	6.24	6.57	6.81	6.99	7.09
	1.66-145	3.4	140°	1.86	2.95	4.09	4.95	5.73	6.18	6.60	6.89	7.10	7.24
		10.3	141°	1.99	3.16	4.37	5.29	5.98	6.62	6.98	7.32	7.55	7.72
	2.53-145	3.4	140°	1.86	2.95	4.09	4.95	5.73	6.18	6.60	6.89	7.10	7.24
		10.3	139°	1.48	2.30	3.00	3.88	4.58	5.30	5.72	6.14	6.53	6.74
2.85-145	3.4	152°	1.83	3.66	4.88	5.49	6.10	6.71	7.32	7.92	8.53	9.14	
	10.3	152°	2.13	3.05	4.27	4.88	5.18	5.49	6.10	6.71	7.32	7.92	
3/4"	3.35-145	3.4	139°	1.38	2.49	3.38	4.10	4.84	5.39	5.81	6.19	6.45	6.63
		10.3	128°	1.53	2.37	3.42	4.26	5.13	5.77	6.25	6.60	6.91	7.13
	4.43-145	3.4	134°	1.41	2.89	3.75	4.66	5.34	5.85	6.24	6.59	6.84	7.01
		10.3	135°	1.60	2.86	3.86	4.88	5.62	6.17	6.65	6.98	7.20	7.37
	5.69-145	3.4	136°	1.84	2.91	3.78	4.69	5.37	6.00	6.36	6.70	6.93	7.09
		10.3	135°	1.60	2.86	3.86	4.88	5.62	6.17	6.65	6.98	7.20	7.37

Standard Materials: Brass and 316 Stainless Steel.

Flow Rate (L/min) = K (BAR) <sup>0.50</sup>

# N

## Fire Protection

### DESIGN FEATURES

- Simplicity of design
- One-piece/no internal parts
- Clog-resistant
- Three standard pipe sizes—1/2", 1" and 1-1/2"
- Male connection
- Factory Mutual, U.S. Coast Guard, and Lloyd's Register approved models

### SPRAY CHARACTERISTICS

- Two spray cones: an outer, wide angle cone and a narrower inner cone combine to give full cone effect

**Spray pattern:** Full Cone

**Spray angles:** 90° and 120° standard

**Flow rates:** 9.67 to 1720 l/min



Nozzle with optional protective cover

Use of blow-off covers requires a pressure of 25 PSI or higher



Full Cone 90°



Full Cone 120° (W)

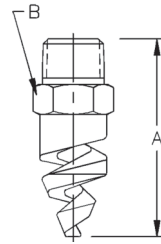

N6 nozzles protect a propane storage tank from fire and explosion.



**N3-N5W: U.S. Coast Guard approved**

TF24-150° also available in Factory Mutual approved model (see page 20)

Dimensions are approximate. Check with BETE for critical dimension applications.

### N Flow Rates and Dimensions

Full Cone, Medium 90° and Wide 120° (W) Spray Angles, 1/2" to 1 1/2" Pipe Sizes, BSP or NPT

Male Pipe Size	Nozzle Number	K Factor	LITERS PER MINUTE @ BAR								Approx. (mm)		Approximate Dimensions (mm)		Wt. (g) Metal
			0.5 bar	0.7 bar	1 bar	2 bar	3 bar	5 bar	10 bar	20 bar	Orifice Dia.	Free Pass. Dia.	A	B	
1/2	N1	13.7	9.67	11.4	13.7	19.3	23.7	30.6	43.2	61.1	4.73	3.18	63.5	22.4	85
	N2	24.2	17.1	20.2	24.2	34.2	41.8	54.0	76.4	6.73	3.18				
	N3	37.6	26.6	31.5	37.6	53.2	65.1	84.1	119	168	8.71	3.18			
	N4	54.9	38.8	46.0	54.9	77.7	95.1	123	174	246	10.9	4.76			
	N5	75.2	53.2	62.9	75.2	106	130	168	238	336	13.5	4.76			
	N6	95.7	67.7	80.1	95.7	135	166	214	303	428	14.3	4.76			
1	N6	95.7	67.7	80.1	95.7	135	166	214	303	428	15.2	4.76	92.2	35.1	241
	N7	153	108	128	153	216	264	341	483	683	19.6	6.35			
1 1/2	N8	216	153	181	216	306	375	484	685	968	23.6	6.35	111	50.8	765
	N9	294	208	246	294	416	509	657	930	1320	27.7	7.94			
	N10	385	272	322	385	545	667	861	1220	1720	32.8	7.94			

$$\text{Flow Rate (l/min)} = K \sqrt{\text{bar}}$$

**Standard Nozzle Materials: Brass and 316 Stainless Steel**

Available in nickel aluminum bronze and titanium, plus other materials available on request.

**Standard Cover Materials: Brass for brass nozzles, 304 Stainless Steel for other nozzle materials**

Spray angle performance varies with pressure.  
Contact BETE for specific data on critical applications.



All N1-N3W nozzles provided with integral strainer.  
Strainer material: 316SS  
24 mesh (0.027" opening)

SPECIAL PURPOSE

TO ORDER: specify pipe size, connection type, nozzle number, and material.

# TF29-180

## FireBeter: Ultra-Wide Full Cone Coverage

### DESIGN FEATURES

- Two-turn spiral
- Ultra-wide spray coverage very close to the nozzle
- One-piece design/no internal parts
- Excellent choice for deluge applications where there is little distance between nozzle and material being protected

### SPRAY CHARACTERISTICS

- Wide spray coverage
  - Fine atomization
- Spray patterns:** circular sheet with maximum coverage and excellent atomization
- Spray angle:** 180° extra-wide angle
- Flow rates:** 12.3 to 355 l/min

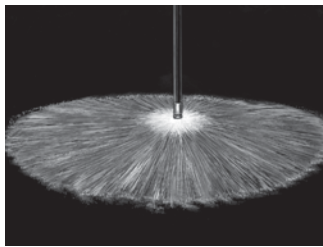

Full Cone 180°

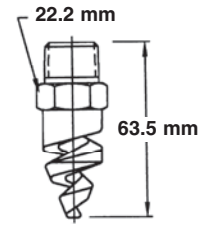
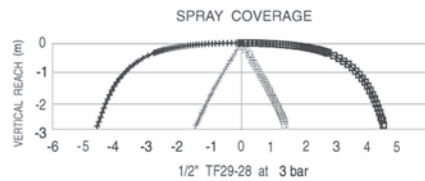
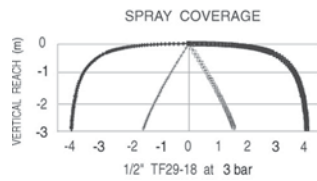

Dimensions are approximate. Check with BETE for critical dimension applications.

### TF29-180 Flow Rates and Dimensions

Full Cone, 180° Extra Wide Spray Angle, 1/2" Pipe Size, BSP or NPT

Male Pipe Size	Nozzle Number	K Factor	LITERS PER MINUTE @ BAR								Approx. Free Pass. & Orifice Dia. (mm)
			0.5 bar	0.7 bar	1 bar	2 bar	3 bar	5 bar	10 bar	20 bar	
1/2	TF29-180-16	17.3	12.3	14.5	17.3	24.5	30.0	38.8	54.8	77.5	5.16
	TF29-180-18	27.4	19.4	22.9	27.4	38.7	47.4	61.2	86.5	122	6.35
	TF29-180-21	33.1	23.4	27.7	33.1	46.8	57.3	73.9	105	148	7.14
	TF29-180-24	43.3	30.6	36.3	43.3	61.3	75.1	96.9	137	194	8.33
	TF29-180-28	56.3	39.8	47.1	56.3	79.7	97.6	126	178	252	9.53
	TF29-180-32	79.4	56.1	66.4	79.4	112	137	177	251	355	11.1

$$\text{Flow Rate (l/min)} = K\sqrt{\text{bar}}$$

Standard Materials: Brass and 316 Stainless Steel.

Spray angle performance varies with pressure. Contact BETE for specific data on critical applications.

SPECIAL PURPOSE

CALL 413-772-0846  
Call for the name of your nearest BETE representative.



# Twist & Dry®

## Twist & Dry Component System

The Twist & Dry® series of nozzles was designed and developed for the spray drying industry, with the dryer operator specifically in mind. The patented locking system locks the swirl and orifice components into place prior to installation on the spray lance, eliminating many of the hassles associated with replacing wear parts and allowing for easier installs. Through continuous development and innovation, BETE offers solutions for high pressure, high temperature, and abrasive media applications.

### DESIGN FEATURES

- Product consistency
- Premium tungsten carbide disc available for extended wear life
- Hand tighten - no special tools required for assembly
- Easy to maintain
- Clog-resistant design
- 218SS body for anti-galling

### SPRAY SET-UPS

The spray angle and flow rate of a Twist and Dry assembly is determined by the swirl and orifice combination. The Twist & Dry series has almost 1,000 different combinations of swirl and orifice discs to provide flow rates and spray angles that best to fit your needs. To locate the right swirl and orifice combination refer to the following TD/TD-K and TDL pages.



TD swirl disc

TD orifice disc

### TD Series

The original TD series features BETE's innovative and patented locking lug feature, single piece thick swirl component, clog-resistant design, and multiple carrier options to provide ease of installation, operation, and maintenance.

- BETE's patented lug design
- Clog-resistant design

### TDL Series

The TDL series offers a compact nozzle design that is ideal for small-scale applications and pilot testing.

- BETE's patented lug design
- Small-scale applications
- Pilot testing



TDL Assembly

### TD-K High Pressure Design

The TD-K series incorporates a PEEK back-up ring and optional Duplex carrier to allow for operation in high-pressure applications. Higher operating pressures can help increase yield, saving time and money. The TD series includes:

- TD-7K: rated for 485 bar
- TD-10K: rated for 690 bar

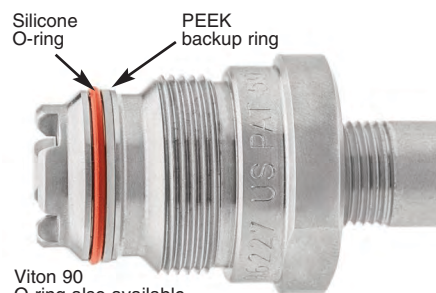

Viton 90 O-ring also available

Side View: TD-K body with PEEK backup ring

Tungsten Carbide Options	
Pro Grade	Suitable for most general spray drying applications
Premium Grade	Superior wear resistance for extremely abrasive spray media

### High Temperature (HT) Design

The HT set-up utilizes a special body design and carrier #7 to replace the traditional O-ring seals with metal gaskets, allowing for operation at high temperatures.

- HT rated for 485 bar at 427 °C
- No O-rings



HT Assembly

### TD/TD-K Drip Pro Check Valve

The TD Drip Pro check valve's patented design offers a high-flow solution to reduce drips which can lead to scorched particles and ruined product.

- Fits standard BETE carriers
- Replaces standard TD/TD-K bodies (except HT set-up)
- Drip-free operation
- Easy to assemble



Drip Pro Check Valve

Same day shipping for wear parts!

SPECIAL PURPOSE

TO ORDER: specify pipe size, connection type, nozzle number, and material. 413-772-0846

# Twist & Dry® Components & Options

Talk to one of our engineers; we're here to help you find the right solution for your application.  
413-772-0846

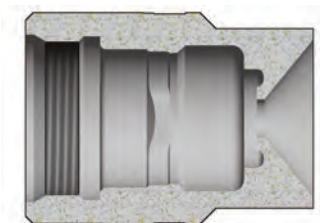

**Durable Beard-Deterring**

Carrier 1 (C11) (shown)  
Carrier 11 (C111) - without lug

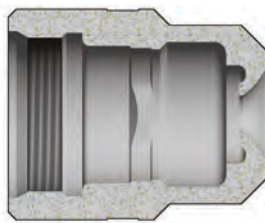

**Standard Carrier**

Carrier 2 (C12) (shown)  
Carrier 5 (C15) - without lug

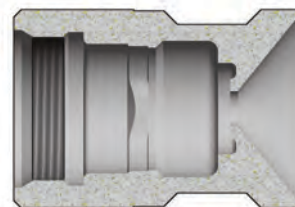

**Knife Edge Anti-Bearding**

Carrier 10 (C110) (shown)  
Carrier 12 (C112) - without lug

## To Order: Spray Set-up Number

**1/4 TD 2 - 025 - C11 - 7K - 45 - CVB - B**

**pipe size**  
add **xx-BW** if Butt Weld  
(include pipe schedule where xx)

**series**

**swirl number**

**orifice**

**carrier style**  
omit for standard carrier (model #2)  
or if using HT set-up (HT body and carrier #7)

**pressure**  
omit for TD/TDL or if using HT set-up (HT body and carrier #7)

**7K** see Material Selection Guide  
includes PEEK backup ring

**10K** see Material Selection Guide  
includes PEEK backup ring and Duplex 2205 carrier material

**connection type**  
omit if NPT or Butt Weld  
**B** if BSP

**check valve**  
omit if no check valve is needed  
or using HT body  
**CVB** for 30 psi (2 bar) cracking pressure  
**CVC** for 75 psi (5 bar) cracking pressure

**temperature**  
omit if temperature is less than or equal to 400 °F (204 °C)  
**45** if temperature is greater than 400 °F (204 °C)  
and less than or equal to 450 °F (232 °C);  
includes Silicone O-ring and PTFE CV seal if applicable  
**HT** if temperature is greater than 450 °F (232 °C)  
and less than or equal to 800 °F (427 °C);  
max pressure 7000 psi (485 bar)

## Twist & Dry Material Selection Guide

Pressure		Temperature			
psi	bar	up to 302 °F (150 °C)	up to 400 °F (204 °C)	up to 450 °F (232 °C)	up to 800 °F (427 °C)
10,000	690	<b>10K Set-up</b> Viton O-ring w/ PEEK Backup Ring Carrier in Duplex 2205	<b>10K Set-up</b> Viton O-ring w/ PEEK Backup Ring Carrier in Duplex 2205	<b>10K Set-up</b> Silicone O-ring w/ PEEK Backup Ring Carrier in Duplex 2205	<b>HT Set-up</b> Metal Gaskets High Temperature Body Carrier #7
7,000	485	<b>7K Set-up</b> Viton O-ring w/ PEEK Backup Ring	<b>7K Set-up</b> Viton O-ring w/ PEEK Backup Ring	<b>7K Set-up</b> Silicone O-ring w/ PEEK Backup Ring	
5,000	345	<b>TD/TDL Set-up</b> Viton O-ring	<b>TD/TDL Set-up</b> Viton O-ring	<b>TD/TDL Set-up</b> Silicone O-ring	
3,500	240				
800	55				

SPECIAL PURPOSE

CALL 413-772-0846  
Call for the name of your nearest BETE representative.

# TD/TD-K

## Twist & Dry® Hollow Cone

### DESIGN FEATURES

- Patented locking mechanism for quick and easy change-out and maintenance

### High pressure applications:

- TD-K with PEEK backup ring
- HT body with Carrier #7

### High temperature applications:

- TD/TD-K bodies with silicone O-ring
- HT body with Carrier #7

- Female-threaded or butt weld connections
- Hand tighten, no special tools required
- Orifice size: 0.864mm through 3.99mm
- Interchangeable swirl and orifice discs for variable patterns and flow rates

- Drip Pro check valve available upon request
- **Multiple grades of tungsten carbide to suit application needs**

- Same day shipping of wear parts
- Clog-resistant design
- Easy to maintain

### SPRAY CHARACTERISTICS

**Spray pattern:** Hollow Cone

**Flow rates:** 35.3 to 8,379 L/h

**Spray angle:** 50° through 85°, as listed



TD Assembly



70° Hollow Cone



Cutaway view of carrier showing BETE's unique locking lug feature

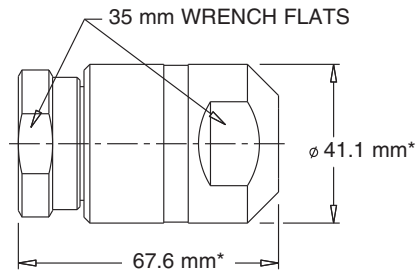

Pipe Size	Weight* (g)
1/4"	539
3/8"	524
1/2"	510
3/4"	482

Dimensions are approximate. Check with BETE for critical dimension applications.

### Twist & Dry/TD-K Flow Rates

Hollow Cone; 50° to 85° Spray Angles; 1/4", 3/8", 1/2", and 3/4" Pipe Sizes; NPT, BSP, or Weld Prep

Female Pipe Size	Nozzle Number	Spray Angle	Swirl	Orifice Dia (mm)	K Factor	LITERS PER HOUR @ BAR										Use TD-K for operation over 240 bar		
						15 bar	35 bar	50 bar	70 bar	90 bar	100 bar	120 bar	150 bar	175 bar	200 bar	300 bar	500 bar	690 bar
1/4"	TD2-34	70°	SW2	0.864	9.12	35.3	53.9	64.5	76.3	86.5	91.2	99.9	112	121	129	158	204	240
	TD1-37	80°	SW1	0.94														
	TD2-40	75°	SW2	1.02														
OR	TD1-49	85°	SW1	1.24	11.4	44.1	67.4	80.6	95.3	108	114	125	140	151	161	197	255	299
	TD4-34	60°	SW4	0.864														
	TD3-40	70°	SW3	1.02														
3/8"	TD5-34	50°	SW5	0.864	16.0	61.8	94.4	113	133	151	160	175	195	211	226	277	358	420
	TD4-40	65°	SW4	1.02														
	TD4-43	65°	SW4	1.09														
OR	TD3-49	75°	SW3	1.24	18.2	70.6	108	129	153	173	182	200	223	241	258	315	407	478
	TD6-37	50°	SW6	0.94														
	TD5-40	60°	SW5	1.02														
1/2"	TD4-46	70°	SW4	1.17	20.5	79.4	121	145	172	195	205	225	251	271	290	355	458	538
	TD3-55	75°	SW3	1.40														
	TD6-40	50°	SW6	1.02														
OR	TD5-43	60°	SW5	1.09	22.8	88.3	135	161	191	216	228	250	279	301	322	395	510	599
	TD4-52	70°	SW4	1.32														
	TD5-49	60°	SW5	1.24														
3/4"	TD4-58	70°	SW4	1.47	25.1	97.1	148	177	210	238	251	275	307	332	355	435	561	659
	TD3-67	80°	SW3	1.70														

Flow Rate (L/h) = K √ bar

Standard Materials: Carrier: Stainless Steel, Duplex; Body: Stainless Steel; Swirl/Orifice: Tungsten Carbide

Spray angle performance varies with pressure. Contact BETE for specific data on critical applications.

SPECIAL PURPOSE

TO ORDER: specify pipe size, connection type, nozzle number, and material. 413-772-0846

### Twist & Dry/TD-K Flow Rates

Hollow Cone; 50° to 80° Spray Angles; 1/4", 3/8", 1/2", and 3/4" Pipe Sizes; NPT, BSP, or Weld Prep

Female Pipe Size	Nozzle Number	Spray Angle	Swirl	Orifice Dia (mm)	K Factor	LITERS PER HOUR @ BAR										Use TD-K for operation over 240 bar		
						15 bar	35 bar	50 bar	70 bar	90 bar	100 bar	120 bar	150 bar	175 bar	200 bar	300 bar	500 bar	690 bar
1/4"	TD6-46	55°	SW6	1.17	27.4	106	162	193	229	259	273	300	335	362	387	475	613	720
	TD5-52	65°	SW5	1.32														
	TD4-61	75°	SW4	1.55														
	TD3-70	80°	SW3	1.78														
	TD6-52	55°	SW6	1.32	31.9	124	189	226	267	303	319	349	391	422	451	553	713	838
	TD5-58	65°	SW5	1.47														
	TD4-70	75°	SW4	1.78														
	TD7-49	50°	SW7	1.24	36.5	141	216	258	305	346	365	399	447	482	516	632	816	959
	TD6-55	60°	SW6	1.4														
	TD5-64	70°	SW5	1.63														
	TD4-76	80°	SW4	1.93														
	TD7-52	50°	SW7	1.32	41.0	159	243	290	343	389	410	449	502	543	580	710	917	1077
TD6-61	60°	SW6	1.55															
TD5-70	70°	SW5	1.78															
OR	TD7-58	55°	SW7	1.47	45.6	177	270	322	381	432	456	499	558	603	645	790	1020	1198
	TD6-64	65°	SW6	1.63														
	TD5-76	75°	SW5	1.93														
	TD4-91	80°	SW4	2.31														
OR	TD7-61	55°	SW7	1.55	50.1	194	297	355	419	476	501	549	614	663	709	868	1120	1316
	TD6-70	65°	SW6	1.78														
	TD5-82	75°	SW5	2.08														
3/8"	TD7-64	55°	SW7	1.63	54.7	212	324	387	458	519	547	599	670	724	773	947	1223	1437
	TD6-76	65°	SW6	1.93														
	TD5-88	75°	SW5	2.24														
OR	TD8-67	50°	SW8	1.7	68.4	265	404	483	572	649	684	749	837	904	967	1185	1529	1797
	TD7-76	60°	SW7	1.93														
	TD6-88	70°	SW6	2.24														
OR	TD5-109	80°	SW5	2.77	82.0	318	485	580	686	778	820	899	1010	1090	1160	1420	1834	2154
	TD8-76	50°	SW8	1.93														
	TD7-85	65°	SW7	2.16														
OR	TD6-103	75°	SW6	2.62	95.7	371	566	677	801	908	957	1050	1170	1270	1350	1658	2140	2514
	TD8-82	55°	SW8	2.08														
	TD7-97	65°	SW7	2.46														
1/2"	TD6-115	75°	SW6	2.92	109	424	647	773	915	1040	1090	1200	1340	1450	1550	1888	2437	2863
	TD9-82	50°	SW9	2.08														
	TD8-91	60°	SW8	2.31														
OR	TD7-106	70°	SW7	2.69	123	477	728	870	1030	1170	1230	1350	1510	1630	1740	2130	2750	3231
	TD6-127	80°	SW6	3.23														
	TD9-88	50°	SW9	2.24														
OR	TD8-100	60°	SW8	2.54	137	530	809	967	1140	1300	1370	1500	1680	1810	1930	2373	3063	3599
	TD7-118	70°	SW7	3.00														
	TD6-142	80°	SW6	3.61														
OR	TD9-94	55°	SW9	2.39	160	618	944	1130	1340	1510	1600	1750	1950	2110	2260	2771	3578	4203
	TD8-106	65°	SW8	2.69														
	TD7-127	75°	SW7	3.23														
3/4"	TD9-106	55°	SW9	2.69	182	706	1080	1290	1530	1730	1820	2000	2230	2410	2580	3152	4070	4781
	TD8-121	65°	SW8	3.07														
	TD7-145	75°	SW7	3.68														
OR	TD10-103	50°	SW10**	2.62	205	794	1210	1450	1720	1950	2050	2250	2510	2710	2900	3551	4584	5385
	TD9-115	60°	SW9	2.92														
	TD8-133	70°	SW8	3.38														
OR	TD10-118	55°	SW10**	3.00	228	883	1350	1610	1910	2160	2280	2500	2790	3020	3220	3949	5098	5989
	TD9-127	60°	SW9	3.23														
	TD8-145	70°	SW8	3.68														
OR	TD9-136	65°	SW9	3.45	251	971	1480	1770	2100	2380	2510	2750	3070	3320	3550	4347	5613	6593
	TD8-157	75°	SW8	3.99														
	TD9-148	65°	SW9	3.76														
OR	TD10-136	60°	SW10**	3.45	274	1060	1620	1930	2290	2590	2740	3000	3350	3620	3870	4746	6127	7197
	TD9-154	70°	SW9	3.91														
	TD10-151	60°	SW10**	3.84														
OR	TD10-157	65°	SW10**	3.99	319	1240	1890	2260	2670	3030	3190	3500	3910	4220	4510	5525	7133	8379

Flow Rate (L/h) = K √ bar

Standard Materials: Carrier: Stainless Steel, Duplex; Body: Stainless Steel; Swirl/Orifice: Tungsten Carbide

Spray angle performance varies with pressure. Contact BETE for specific data on critical applications.

\*\*SW10 only available in Pro Grade Tungsten Carbide



# TDL

## Twist & Dry® Low Flow Hollow Cone

### DESIGN FEATURES

- Patented locking mechanism for quick and easy change-out and maintenance
- Lower flow rates than the Twist & Dry series
- Female-threaded or butt weld pipe connections
- Orifice size: 0.457mm through 1.47mm
- Interchangeable swirl and orifice discs for variable patterns and flow rates

### SPRAY CHARACTERISTICS

- Hollow Cone
- Flow rates:** 11.3 to 416 L/h
- Spray angle:** 70° - 75°

Ideal for small-scale applications and pilot tests



Female



70° Hollow Cone

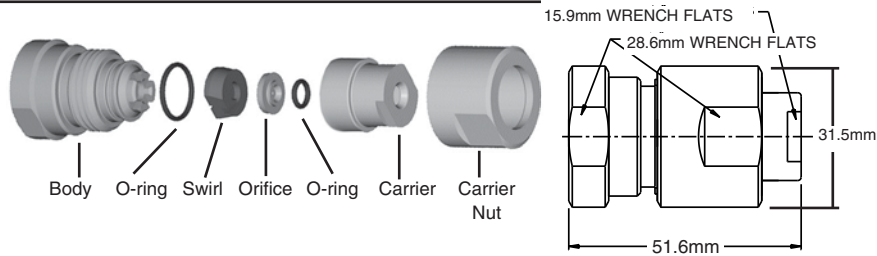

Pipe Size	Weight (g)
1/4"	119
3/8"	107

Dimensions are approximate. Check with BETE for critical dimension applications.

### TDL Flow Rates

Hollow Cone; 70° - 75° Spray Angles; 1/4" and 3/8" Pipe Sizes; NPT or BSP

Female Pipe Size	Nozzle Number	Swirl	Orifice Dia. (mm)	K Factor	LITERS PER HOUR @ BAR										
					15 bar	35 bar	50 bar	70 bar	90 bar	100 bar	120 bar	150 bar	175 bar	200 bar	275 bar
1/4"	TDL4-18	SWL4	0.457	2.92	11.3	17.3	20.6	24.4	27.7	29.2	32.0	35.7	36.6	41.3	48.4
	TDL4-20	SWL4	0.508	3.10	12.0	18.3	21.9	25.9	29.4	31.0	34.0	38.0	41.0	43.8	51.4
	TDL4-22	SWL4	0.559	3.42	13.2	20.2	24.2	28.6	32.4	34.2	37.4	41.9	45.2	48.3	56.7
	TDL4-24	SWL4	0.610	3.92	15.2	23.2	27.7	32.8	37.2	39.2	42.9	48.0	51.9	55.4	65.0
	TDL4-27	SWL4	0.686	4.56	17.7	27.0	32.2	38.1	43.2	45.6	49.9	55.8	60.3	64.5	75.6
	TDL1-22	SWL1	0.559	5.01	19.4	29.7	35.5	41.9	47.6	50.1	54.9	61.4	66.3	70.9	83.1
	TDL1-24	SWL1	0.610	5.70	22.1	33.7	40.3	47.7	54.0	57.0	62.4	69.8	75.4	80.6	94.5
	TDL1-27	SWL1	0.686	6.61	25.6	39.1	46.7	55.3	62.7	66.1	72.4	80.9	87.4	93.5	110
	TDL1-30	SWL1	0.762	7.52	29.1	44.5	53.2	62.9	71.3	75.2	82.4	92.1	99.5	106	125
	TDL2-30	SWL2	0.762	9.12	35.3	53.9	64.5	76.3	86.5	91.2	100	112	121	129	151
OR	TDL2-33	SWL2	0.838	10.3	39.7	60.7	72.5	85.5	97.3	103	112	126	136	145	170
	TDL2-36	SWL2	0.914	11.4	44.1	67.4	80.6	95.3	108	114	125	140	151	161	189
	TDL2-38	SWL2	0.965	12.1	46.8	71.5	85.4	101	115	121	132	148	160	171	200
	TDL2-40	SWL2	1.02	13.2	51.2	78.2	93.5	111	125	132	145	162	175	187	219
	TDL2-42	SWL2	1.07	13.7	53.0	80.9	96.7	114	130	137	150	167	181	193	227
	TDL2-44	SWL2	1.12	14.1	54.7	83.6	100	118	134	141	155	173	187	200	234
	TDL2-46	SWL2	1.17	14.8	57.4	87.6	105	124	141	148	162	181	196	209	246
	TDL2-48	SWL2	1.22	16.0	61.8	94.4	113	133	151	160	175	195	211	226	265
	TDL2-50	SWL2	1.27	16.6	64.4	98.4	118	139	158	166	182	204	220	235	276
	TDL2-52	SWL2	1.32	18.0	69.7	107	127	151	171	180	197	220	238	255	298
3/8"	TDL2-54	SWL2	1.37	18.7	72.4	111	132	156	177	187	205	229	247	264	310
	TDL2-56	SWL2	1.42	19.1	74.1	113	135	160	182	191	210	234	253	271	317
	TDL3-50	SWL3	1.27	20.4	79.1	121	144	171	194	204	224	250	270	289	339
	TDL3-52	SWL3	1.32	21.8	84.4	129	154	182	207	218	239	267	288	308	361
	TDL3-54	SWL3	1.37	23.0	89.1	136	163	193	218	230	252	282	304	326	382
	TDL3-56	SWL3	1.42	24.4	94.4	144	172	204	231	244	267	299	323	345	404
	TDL3-58	SWL3	1.47	25.1	97.1	148	177	210	238	251	275	307	332	355	416

$$\text{Flow Rate (L/h)} = K \sqrt{\text{bar}}$$

Standard Materials: Carrier: Stainless Steel; Body: Stainless Steel; Swirl/Orifice: Tungsten Carbide

Spray angle performance varies with pressure. Contact BETE for specific data on critical applications.

[www.BETE.com](http://www.BETE.com)

SPECIAL PURPOSE

TO ORDER: specify pipe size, connection type, nozzle number, and material. 413-772-0846

# TurboMix®

## TurboMix® Eductor Mixing Nozzle

### DESIGN FEATURES

- Effective, economical way to circulate liquids in closed or open tanks
- No moving parts
- Inherently clog resistant
- Requires minimal maintenance
- Nozzle operation creates multiplying effect on fluid flow
- The volume of discharge liquid will be 3-5 times greater than the motive liquid pumped

### SPRAY CHARACTERISTICS

- Cone-shaped plume
- Flow rates:** 26.7 to 12000 L/min (motive)

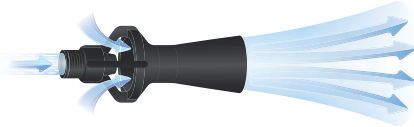

Metal

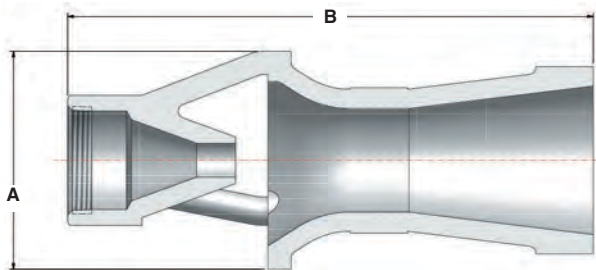

Metal

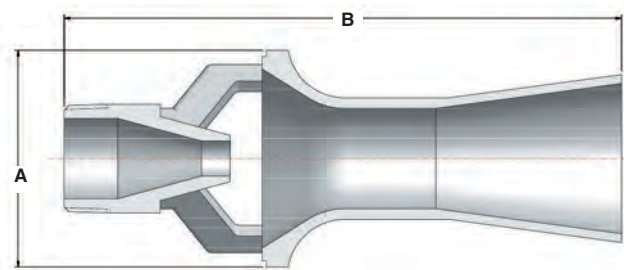

Plastic

Dimensions are approximate. Check with BETE for critical dimension applications.

### TurboMix in Molded Plastic

NPT or BSP Connection Size	TurboMix Number	K Factor	Motive Flow Rate LITERS PER MINUTE @ BAR*								Dimensions (mm)		Weight (kg)
			0.7 bar	1 bar	1.5 bar	2 bar	2.5 bar	3 bar	3.5 bar	A	B		
Male	3/8	TM73	33.2	27.8	33.2	40.7	47	52.5	57.6	62.2	54	114	0.03
	1/2	TM120	54.3	45.4	54.3	66.5	76.7	85.8	94	101	64	165	0.04
	3/4	TM137	62.4	52.2	62.4	76.4	88.2	98.6	108	117	73	162	0.06
	1	TM240	109	90.8	108	133	153	172	188	203	89	241	0.15
	1 1/2	TM340	155	130	155	190	219	245	269	290	114	248	0.21

Standard Material: Glass-filled Polypropylene. \*BAR = supply pressure at the TurboMix minus the pressure in the tank

### TurboMix in Metal

NPT or BSP Connection Size	TurboMix Number	K Factor	Motive Flow Rate LITERS PER MINUTE @ BAR*								Dimensions (mm)		Weight (kg)
			0.7 bar	1 bar	1.5 bar	2 bar	3 bar	5 bar	7 bar	A	B		
Male	3/8	TM70	31.9	26.7	31.9	39.1	45.1	55.3	71.4	84.4	43	108	0.23
	1/2	TM110	50.1	41.9	50.1	61.3	70.8	87.0	112	132	55	133	0.34
	3/4	TM150	68.4	57.2	68.4	83.7	96.7	118	153	181	67	159	0.68
	1	TM230	105	87.7	105	128	148	182	234	277	83	200	1.25
Female	1 1/2	TM320	146	122	146	179	206	253	326	386	97	233	2.95
	2	TM620	282	236	282	345	399	489	631	746	121	286	5.67
	3	TM1500	684	572	684	837	967	1180	1530	1810	146	492	18.1
Flanged (PN6)	4	TM2510	1130	950	1130	1390	1610	1970	2540	3000	213	864	18.1
	6	TM6010	2720	2270	2720	3330	3840	4710	6080	7190	321	1320	54.4
	8	TM10050	4550	3800	4550	5570	6430	7870	10200	12000	416	1730	147

Motive Flow Rate (l/min) =  $K \sqrt{\text{bar}}$  \*BAR = supply pressure at the TurboMix minus the pressure in the tank

Standard Materials: Brass (up to 3", inclusive), Carbon Steel, 316 Stainless Steel.

SPECIAL PURPOSE

Call for the name of your nearest BETE representative.

CALL 413-772-0846

# IS

## Rectangular Coverage/Mounted in Pairs

### DESIGN FEATURES

- Effective wherever rectangular pattern is required
- High energy efficiency
- Low coefficient of discharge and large unimpeded openings
- Excellent clog resistance
- Mounted in opposing pairs
- Male connection

### SPRAY CHARACTERISTICS

- Pattern widths of 18" to 120" can be achieved
- Good distribution with pressures as low as 0.035 bar
- Thick bands of droplets from opposing pairs intersect and fall uniformly

**Spray pattern:** Rectangular

**Spray angle:** See Pattern Width and Coverage Chart

**Flow rates:** 1.77 to 649 l/min per pair

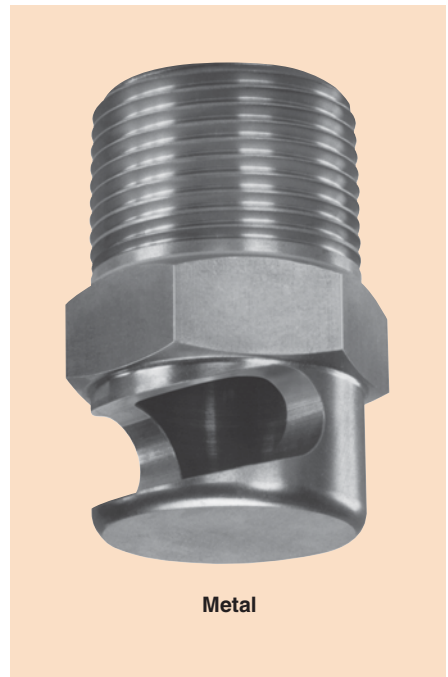

Metal

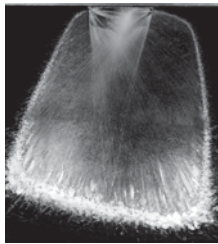

Rectangular Spray

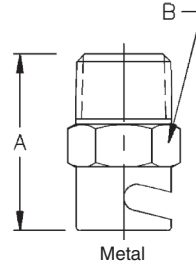
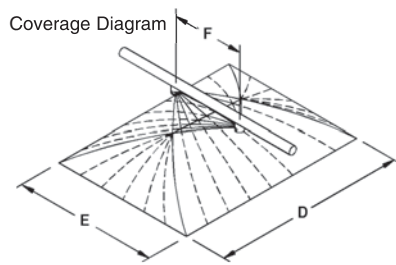

Metal

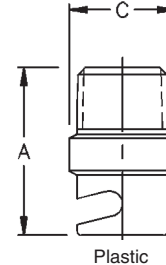

Plastic

Dimensions are approximate. Check with BETE for critical dimension applications.

### IS Flow Rates and Dimensions

Rectangular Spray Pattern, 1/16" to 1 1/2" Pipe Sizes, BSP or NPT

### Coverage

300mm Mounting Height

Male Pipe Size	Nozzle Number	K Factor	LITERS PER MINUTE PER PAIR @ BAR									Nozzle Dim. (mm)			Wt. (g) Metal Plas.	Spacing (mm) F	Approx. Cover. (mm) @ bar							
			0.03 bar	0.07 bar	0.1 bar	0.2 bar	0.5 bar	0.7 bar	1 bar	1.5 bar	A	B	C	0.07 bar			0.1 bar		0.25 bar		0.5 bar			
			D	E	D	E	D	E	D	E	D	E	D	E	D	E	D	E	D	E				
1/16	IS2	10.2	1.77	2.70	3.22	4.56	7.21	8.53	10.2	12.5	19.1	7.87	7.87	4	2	70	600	450	850	650	1500	750	1800	750
	IS3	15.3	2.65	4.04	4.83	6.84	10.8	12.8	15.3	18.7														
1/8	IS4	20.4	3.53	5.39	6.45	9.12	14.4	17.1	20.4	25.0	22.2	12.7	11.1	28	7	100	500	350	800	450	1050	750	1150	900
	IS6	30.6	5.30	8.09	9.67	13.7	21.6	25.6	30.6	37.4														
1/4	IS8	40.8	7.06	10.8	12.9	18.2	28.8	34.1	40.8	49.9	27.0	15.9	14.3	43	11	125	750	450	1000	550	1500	900	1950	1050
	IS10	51.0	8.83	13.5	16.1	22.8	36.0	42.6	51.0	62.4														
3/8	IS12	61.1	10.6	16.2	19.3	27.3	43.2	51.2	61.1	74.9	31.8	19.1	17.5	57	14	150	650	300	900	500	1350	600	1000	600
	IS14	71.3	12.4	18.9	22.6	31.9	50.4	59.7	71.3	87.4														
	IS16	81.5	14.1	21.6	25.8	36.5	57.7	68.2	81.5	99.9														
1/2	IS20	102	17.7	27.0	32.2	45.6	72.1	85.3	102	125	36.5	22.2	22.2	85	28	200	900	300	1500	700	2100	900	2200	1050
	IS24	122	21.2	32.4	38.7	54.7	86.5	102	122	150														
	IS28	143	24.7	37.7	45.1	63.8	101	119	143	175														
3/4	IS32	163	28.2	43.1	51.6	72.9	115	136	163	200	44.5	28.6	28.6	170	43	250	1050	300	1500	500	1650	600	2250	650
	IS40	204	35.3	53.9	64.5	91.2	144	171	204	250														
	IS48	245	42.4	64.7	77.3	109	173	205	245	300														
1	IS56	285	49.5	75.5	90.2	128	202	239	285	349	55.6	34.9	34.9	227	57	300	750	450	1200	500	1550	600	2250	950
	IS64	326	56.5	86.3	103	146	231	273	326	399														
1 1/4	IS72	367	63.5	97.1	116	164	259	307	367	449	63.5	44.5	44.5	340	85	350	1200	350	1500	450	2200	500	2700	600
	IS80	408	70.6	108	129	182	288	341	408	499														
1 1/2	IS88	448	77.7	119	142	201	317	375	448	549	76.2	50.8	50.8	567	142	400	900	350	1200	450	1800	600	3000	950
	IS96	489	84.7	129	155	219	346	409	489	599														
	IS104	530	91.8	140	168	237	375	443	530	649														

$$\text{Flow Rate (l/min)} = K \sqrt{\text{bar}}$$

Standard Materials: Brass, 303 Stainless Steel, 316 Stainless Steel, and PVC

Spray angle performance varies with pressure. Contact BETE for specific data on critical applications.

# LP

## Low Profile

### DESIGN FEATURES

- Provides effective cleaning with low water consumption
- Interchangeable family of shower nozzles
- Self-aligning
- Orifice designed for efficient cleaning

### SPRAY CHARACTERISTICS

**Spray patterns:** Straight Jet and Flat Fan  
**Spray Angles:** 0°, 30° and 60°  
**Flow rates:** 0.041 to 43.9 gpm  
 0.162 to 155 l/min



0° Fan

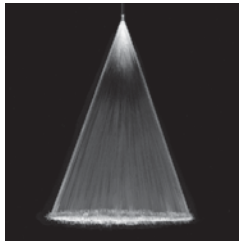

30° Fan

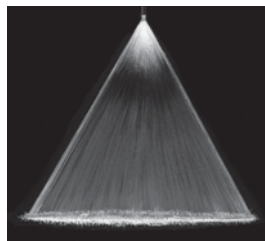

60° Fan



Retaining Ring



LP nozzle



Gasket

Dimensions are approximate. Check with BETE for critical dimension applications.

### LP Flow Rates and Dimensions Fan and Straight Jet, 0°, 30° and 60° Spray Angles

Nozzle Number	Available Spray Angle 0° 30° 60°	K Factor	LITERS PER MINUTE @ BAR					Equivalent Orifice Dia. (mm)
			3 bar	4 bar	5 bar	10 bar	30 bar	
LP0041	0°	0.0937	0.162	0.187	0.209	0.296	0.513	0.4
LP0073	0°	0.167	0.290	0.334	0.374	0.529	0.916	0.6
LP0090	0°	0.205	0.354	0.409	0.458	0.647	1.12	0.7
LP013	0°	0.298	0.517	0.597	0.667	0.943	1.63	0.8
LP023	0° 30° 60°	0.520	0.901	1.04	1.16	1.65	2.85	1.0
LP033	0° 30° 60°	0.744	1.29	1.49	1.66	2.35	4.07	1.2
LP043	0° 30° 60°	0.967	1.68	1.93	2.16	3.06	5.30	1.5
LP08	0° 30° 60°	1.83	3.17	3.66	4.09	5.79	10.0	2.0
LP12	0° 30° 60°	2.82	4.89	5.65	6.32	8.93	15.5	2.5
LP20	0° 30° 60°	4.50	7.79	8.99	10.1	14.2	24.6	3.0
LP31	60°	7.16	12.4	14.3	16.0	22.7	39.2	4.0
LP49	60°	11.2	19.3	22.3	25.0	35.3	61.2	5.0
LP78	60°	17.9	31.0	35.7	40.0	56.5	97.9	6.0
LP99	60°	22.5	38.9	45.0	50.3	71.1	123	7.0
LP124	60°	28.2	48.9	56.5	63.2	89.3	155	8.0

$$\text{Flow Rate (l/min)} = K \sqrt{\text{bar}}$$

Standard Materials: 316 Stainless Steel

Spray angle performance varies with pressure. Contact BETE for specific data on critical applications.

SPECIAL PURPOSE

CALL 413-772-0846  
 Call for the name of your nearest BETE representative.



# PSR

## Small Physical Size Straight Jet

### DESIGN FEATURES

- High velocity jet
- Small physical size
- Small orifice size: 0.035mm through 3.18mm
- **Interchangeable with most other needle-type showers**

### SPRAY CHARACTERISTICS

- Hard driving straight jet
- Flow rates:** 0.075 to 34.1 l/min
- Spray angle:** 0°

### TYPICAL APPLICATIONS

Cleaning, Degreasing,  
Cleaning Wires and Felts—Pulp and Paper



0° Straight Jet

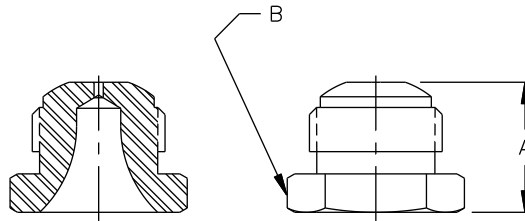

Male

Dimensions are approximate. Check with BETE for critical dimension applications.

### PSR Flow Rates and Dimensions Straight Jet, 9/16"-24 UNEF Thread

Nozzle Number	K Factor	LITERS PER MINUTE @ BAR								Equivalent Orifice Dia. (mm)	Approx. Dim. (mm)		Wt. (g)
		1 bar	3 bar	5 bar	7 bar	10 bar	15 bar	30 bar	60 bar		A	B	
PSR03	0.0752	0.075	0.13	0.16	0.19	0.22	0.27	0.37	0.52	0.356	14.0	17.5	21.3
PSR11	0.258	0.26	0.43	0.55	0.65	0.76	0.92	1.28	1.77	0.711			
PSR16	0.393	0.39	0.67	0.85	1.00	1.19	1.44	2.01	2.80	0.838			
PSR23	0.564	0.56	0.96	1.22	1.44	1.70	2.07	2.89	4.03	1.02			
PSR40	0.981	0.98	1.66	2.12	2.50	2.96	3.60	5.02	7.00	1.40			
PSR67	1.644	1.64	2.79	3.56	4.18	4.96	6.03	8.41	11.7	1.78			
PSR120	2.944	2.94	4.99	6.37	7.49	8.89	10.8	15.1	21.0	2.39			
PSR195	4.784	4.78	8.11	10.4	12.2	14.4	17.6	24.5	34.1	3.18			

$$\text{Flow Rate (l/min)} = K (\text{bar})^{0.48}$$

Standard Materials: 316 Stainless Steel.

SPECIAL PURPOSE

TO ORDER: specify pipe size, connection type, nozzle number, and material.

# FINZ™

## High Impact Fan Air Nozzle

### DESIGN FEATURES

- Controlled wide uniform distribution and high impact coverage of compressed air
- Can be mounted individually or side-by-side for greater coverage
- Efficient air flow rates with unique eductor feature
- Safe operation—meets OSHA specifications for noise and deadhead pressure
- 1/4" male connection is molded to fit either NPT or BSP
- Up to 2dB quieter than competing designs

- Rugged construction of Ryton® or ABS plastic.  
Ryton® (black) rated to 149°C at 3 bar  
ABS (orange) rated to 68°C at 7 bar
- Maximum operating pressure 7 bar

### SPRAY CHARACTERISTICS

**Spray pattern:** Fan

**Air Flow Rates:** 7 to 65 Nm<sup>3</sup>/h at 0.7 to 6 bar

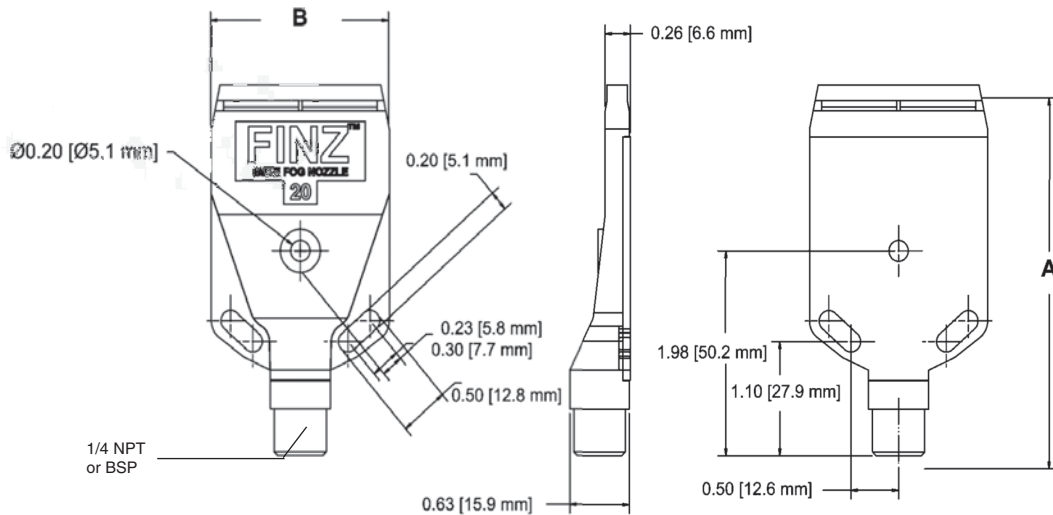

Dimensions are approximate. Check with BETE for critical dimension applications.

### FINZ High Impact Air Nozzle

Male NPT BSP	Nozzle Number	Air Capacity Nm <sup>3</sup> /h				Approx. Dim. (mm)		Wt. (g)
		0.7 bar	2 bar	4 bar	6 bar	A	B	
1/4"	FZ20	7	12	19	26	91	47	28.3
	FZ29	11	21	32	43			
	FZ41	15	28	47	65			

**Standard Materials: Ryton® and ABS plastic.**

*Ryton is a trademark of Phillips Petroleum company*

SPECIAL PURPOSE

CALL 413-772-0846  
Call for the name of your nearest BETE representative.

# SJ

## Swivel Joints

### DESIGN FEATURES

- Adjustable swivel joints allow custom alignment of spray nozzles without expensive piping changes
- Leak-proof design
- Standard materials are brass and stainless steel
- Other materials available upon request

### SPRAY CHARACTERISTICS

- **Adjustment angles:** From 30° to 45°
- Greater control of spray direction for precise coverage

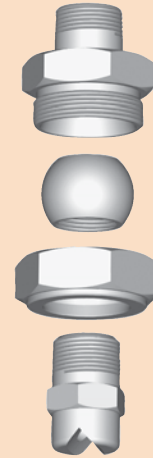

Adjustable Swivel Joints aid in aligning spray nozzles

(Optional NF nozzle shown, choose nozzle when ordering)

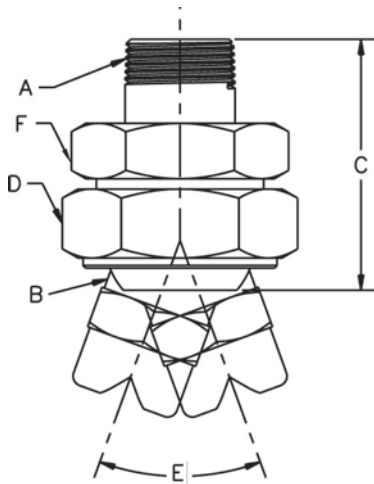

Dimensions are approximate. Check with BETE for critical dimension applications.

### Swivel Joint Dimensions







Part Number	A Inlet Pipe Conn. BSP or NPT	B Outlet Pipe Conn. BSP or NPT	C Overall Length (mm)	D Hex Size (mm)	E Angle of Adjustment	F Hex Size (mm)	Net Wt. (g)
1/8 X 1/8 SJ	1/8 M	1/8 F	31.8	20.7		20.7	56.7
1/4 X 1/4 SJ	1/4 M	1/4 F	38.1	28.7		25.4	111
3/8 X 1/4 SJ	3/8 M	1/4 F	44.5	38.1	45°	35.1	244
3/8 X 3/8 SJ	3/8 M	3/8 F	45.5	38.1		35.1	244
1/2 X 3/8 SJ	1/2 M	3/8 F	50.8	44.5		41.4	366
1/2 X 1/2 SJ	1/2 M	1/2 F	50.8	44.5	45°	41.4	346
3/4 X 1/2 SJ	3/4 M	1/2 F	54.1	50.8	45°	47.8	505
3/4 X 3/4 SJ	3/4 M	3/4 F	54.1	50.8	45°	47.8	465
1 X 1 SJ	1 M	1 F	76.2	62.0	45°	57.2	967
1 1/4 X 1 1/4 SJ	1 1/4 M	1 1/4 F	88.9	79.5	30°	73.2	1899
1 1/2 X 1 1/2 SJ	1 1/2 M	1 1/2 F	98.6	85.9	30°	85.9	2679
2 X 2 SJ	2 M	2 F	105	102	40°	88.9	2920

SPECIAL PURPOSE

TO ORDER: specify pipe size, connection type, nozzle number, and material.

# Accessories

## Components & Sizes

	Components	Materials	Sizes												
<b>Nozzle Strainers</b> 	Optional strainer to fit BJ and CW nozzles. All strainers equipped with 316 stainless steel screens of various mesh sizes.	316 stainless steel	US Mesh Sizes: 50 (297 µm) (S201) 100 (149 µm) (S202) 200 (74 µm) (S203) 400 (37 µm) (S204)												
<b>Reducing Bushings</b> 	BETE nozzles are often installed in pipe sizes larger than their connection. These bushings will adapt BETE nozzles to existing piping.	316 stainless steel nickel alloy C-276 nickel alloy 625 PVC PTFE	Bushing Sizes: 1/4 x 1/8 3/8 x 1/8, 1/4 1/2 x 1/8, 1/4, 3/8 1 x 1/4, 3/8, 1/2, 3/4 1-1/2 x 1/4, 1/2, 1 2 x 1/2, 1												
<b>Y-Type Line Strainers</b> 	BETE recommends the use of strainers to minimize clogging. The 1/4" and 3/8" strainers are equipped with 0.25mm-mesh screens, while 1/2" - 2" strainers come with 0.20mm-mesh screens. Screens with mesh sizes of 0.05, 0.06, 0.13 and 0.15mm available by special order. Screens are easily removed for cleaning. 10 bar rating.	Bronze body with heavy-duty stainless steel wire mesh.	Strainer Sizes: 1/4, 3/8, 1/2, 3/4, 1, 1-1/2, 2  <table border="1"> <thead> <tr> <th>Mesh Sizes</th> <th>Screen Opening</th> </tr> </thead> <tbody> <tr> <td>0.25 mm</td> <td>0.13 mm</td> </tr> <tr> <td>0.20 mm</td> <td>0.18 mm</td> </tr> <tr> <td>0.13 mm</td> <td>0.28 mm</td> </tr> <tr> <td>0.06 mm</td> <td>0.71 mm</td> </tr> <tr> <td>0.05 mm</td> <td>0.86 mm</td> </tr> </tbody> </table>	Mesh Sizes	Screen Opening	0.25 mm	0.13 mm	0.20 mm	0.18 mm	0.13 mm	0.28 mm	0.06 mm	0.71 mm	0.05 mm	0.86 mm
Mesh Sizes	Screen Opening														
0.25 mm	0.13 mm														
0.20 mm	0.18 mm														
0.13 mm	0.28 mm														
0.06 mm	0.71 mm														
0.05 mm	0.86 mm														
<b>Adapters and Couplings</b> 	Reducing couplings, socket adapters, elbows, and various other fittings are available to meet specific applications.	Wide range of materials available.	Sizes available as required												
<b>Flanges</b> 	Used to attach nozzles too large to be threaded. 150# rating, ANSI standard; 300# and specific ratings also available.	316 stainless steel nickel alloy C-276 nickel alloy 625 PVC PTFE FRP	Flange Sizes: 2" - 12" DN 50 - DN 300												
<b>Manifolds</b> 	Used to cluster many nozzles into a small physical space	Wide range of materials available	Standard Sizes <table border="1"> <thead> <tr> <th>Inlet</th> <th>Outlets</th> </tr> </thead> <tbody> <tr> <td>1/2"</td> <td>x (7) 3/8"-24 UNF</td> </tr> <tr> <td>3/4"</td> <td>x (6) 1/4" or 3/8"</td> </tr> <tr> <td>1"</td> <td>x (6) 3/8" or 1/2"</td> </tr> </tbody> </table>	Inlet	Outlets	1/2"	x (7) 3/8"-24 UNF	3/4"	x (6) 1/4" or 3/8"	1"	x (6) 3/8" or 1/2"				
Inlet	Outlets														
1/2"	x (7) 3/8"-24 UNF														
3/4"	x (6) 1/4" or 3/8"														
1"	x (6) 3/8" or 1/2"														

SPECIAL PURPOSE

Call for the name of your nearest BETE representative.

CALL 413-772-0846





**SYSTEM DESIGN**

The piping system that supplies the nozzles must be designed to deliver the correct pressure at the nozzle inlet. The following formula

$$P_{\text{Pump}} = P_{\text{Nozzle}} + P_{\text{Pipe Losses}} + \frac{\rho gh}{100000}$$

is useful in estimating the pressure a pump will have to supply to a nozzle system:

where:

$\rho$  = density of fluid (kg/m<sup>3</sup>)

[water = 1000 kg/m<sup>3</sup>]

$g$  = 9.81 m/s<sup>2</sup>

$h$  = height of nozzle above pump (m) - negative if the nozzle is below the pump

$p$  = pressure (bar)

A chart of pipe friction losses is presented on page 125. In using the chart be sure to look at the *total* system flow if there are multiple nozzles to be supplied by one pipe. Elbows, tees and other pipe fittings (see p. 125) also contribute to pressure loss and can be significant, especially in short, convoluted runs.

**SPRAY ANGLE**

The spray angle chosen for a particular application depends on the coverage required.

The spray angle for spiral nozzles is relatively stable over a wide range of pressures, while the spray

**HOLLOW CONE SPRAY PATTERN**

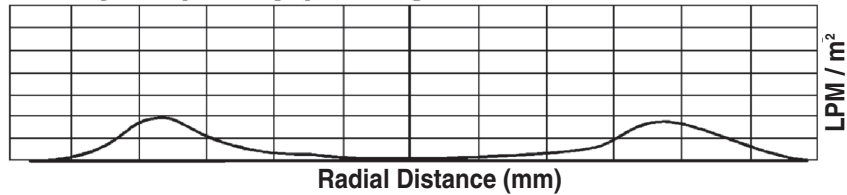

**FULL CONE SPRAY PATTERN**

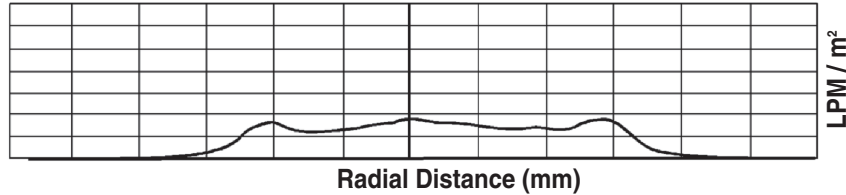

angle for whirl nozzles tends to decrease as the pressure is increased. For additional information see page 124.

**NOZZLE SPRAY PATTERN**

The term "Spray Pattern" describes the location and spray density of the liquid emitted from a nozzle. Two examples of pattern measurement are shown above. The height of the curve at any point is the spray density in units of LPM/m<sup>2</sup>.

**DROPLET SIZE**

Droplet size is often critical. Many processes such as gas scrubbing depend on exposing the maximum possible amount of liquid surface to a gas stream. Other applications require that the droplets be as large as possible, such as when the spray must project into a fast moving gas stream.

Exposing the maximum surface area requires breaking the liquid into droplets as small as possible. To get an idea of how this works, imagine a cube of water with a volume of 1 m<sup>3</sup>. This cube has a surface area of 6 m<sup>2</sup>. If we now split it in two, we expose some of the inner surface and increase the total surface area to 8 m<sup>2</sup>. Atomizing the liquid into spheres 1 mm (1,000 microns) in diameter would increase the surface area of this gallon of liquid to 6000 m<sup>2</sup>.

A nozzle actually produces a range of droplet sizes from the solid liquid stream. Since it is inconvenient to list all the sizes produced, droplet size (in microns) is usually expressed by a mean or median diameter. An understanding of diameter terms is essential.

**Particle Size Spectrum**

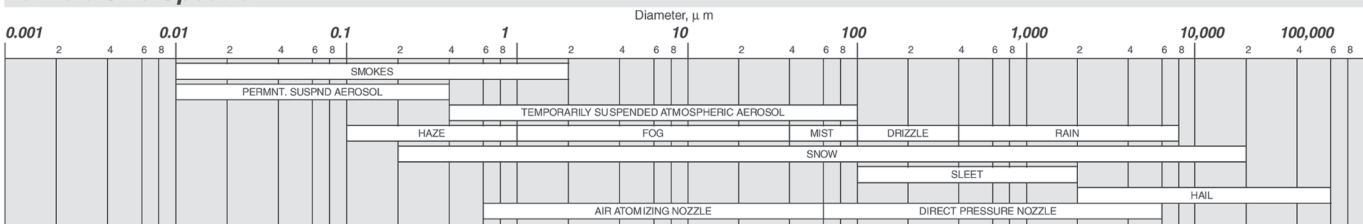

## RELATIVE DROP SIZE BY NOZZLE SERIES

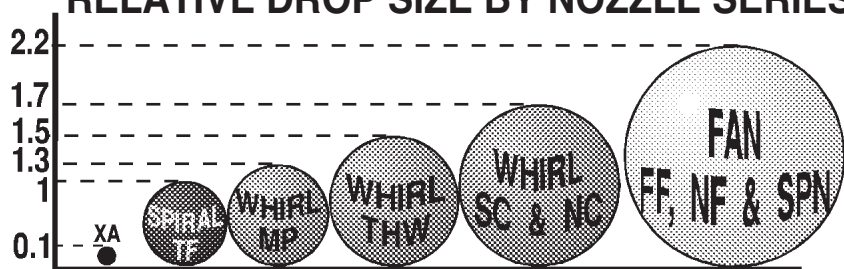

The following definitions are given for the most frequently used mean and median diameters:

### Arithmetic Mean Diameter (D<sub>10</sub>)

- The average of the diameters of all the droplets in the spray sample.

### Volume Mean Diameter (D<sub>30</sub>)

- The diameter of a droplet whose volume, if multiplied by the total number of droplets, will equal the total volume of the sample.

### Sauter Mean Diameter (D<sub>32</sub>):

- The diameter of a droplet whose ratio of volume to surface area is equal to that of the complete spray sample.

### Mass (Volume) Median Diameter (D<sub>V05</sub>):

- The diameter which divides the mass (or volume) of the spray into two equal halves. Thus 1/2 of the total mass is made up of droplets

with diameters smaller than this number and the other half with diameters that are larger.

The Sauter Mean Diameter is one of the most useful ways to characterize a spray. The ratio of volume to surface area for the Sauter Mean is the same as that ratio for the entire spray volume. For this reason, the use of the Sauter Mean is preferred for process calculations.

Whirl nozzles generally produce larger droplets than spiral nozzles,

$$\frac{D_2}{D_1} = \left(\frac{P_2}{P_1}\right)^{-0.3}$$

and air-atomizing nozzles such as the XA or SpiralAir Series typically produce the smallest droplets of all.

It is sometimes useful to predict the effect a change in pressure will have on the droplet size produced

by the nozzle. For single fluid nozzles the following equation may be used for modest changes in pressure.

### TROUBLESHOOTING BASICS

The following are some of the things to look for when a system is not performing as intended:

#### Nozzle Wear or Corrosion

- may cause excessive flow rate due to enlarged passages
- may increase droplet size
- degrades spray pattern

#### Nozzle Clogging

- low flow rates
- poor spray pattern

#### Inadequate Pipe Size

- excessive pipe pressure losses leading to low nozzle pressures
- high velocities in headers that disrupt fluid entering the nozzle

#### Incorrect Nozzle Location

- poor gas/liquid contact in scrubbers and quenchers
- poor area coverage

#### Incorrect Nozzle for Application

- drop size too small or too large
- incorrect pattern type

Careful system design and selection of the proper BETE nozzle will minimize spray problems.

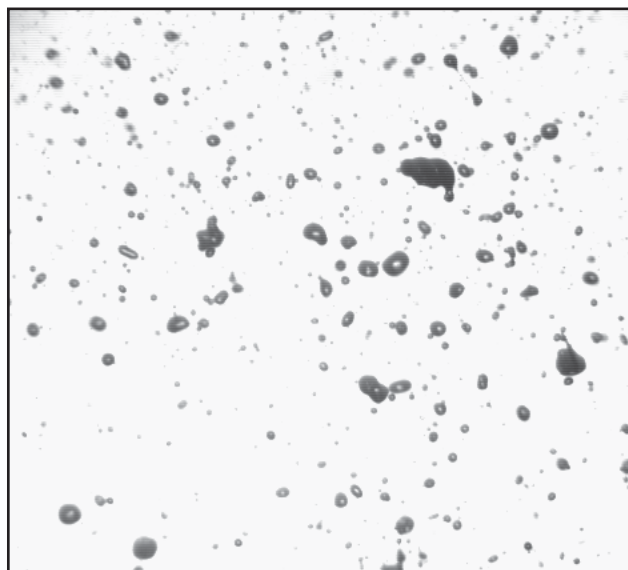

Actual droplet images captured using the BETE Model 700 Spray Analysis System.

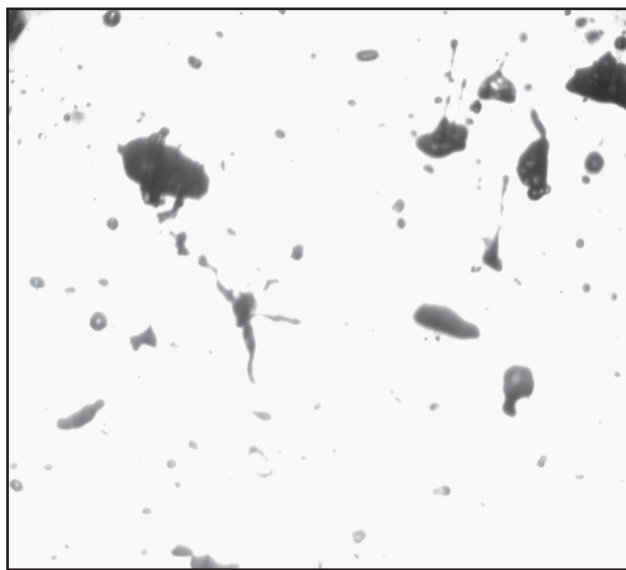

The BETE Droplet Analyzer is capable of characterizing non-spherical droplets like those seen in this actual image.



# Research & Development

## RESEARCH & DEVELOPMENT

BETE's state-of-the-art **Spray Laboratory** plays a key role in supporting both product R&D and our customer service network.

Equipped with sophisticated video-image processing and digital analysis technology, the Spray Lab makes possible rapid nozzle development and evaluation.

The Spray Lab is also available on a contract basis to provide confidential, quantitative evaluation of nozzle performance. Industrial applications for contract testing range from comparative nozzle performance testing to development of proprietary designs. These capabilities allow our customers to optimize process performance while minimizing capital and operating costs—a winning combination in today's competitive global marketplace.

### Spray Laboratory Capabilities

- Flow rate (water) measurements from 0.04 to 7500 l/min
- Flow rate (air) measurements from 0.5 to 2550 Nm<sup>3</sup>/h
- Pressure measurements to 210 bar
- Automated drop size distribution measurement from less than 2 to greater than 15,000 microns
- Computerized spray distribution analysis
- Two-fluid capabilities up to 2550 Nm<sup>3</sup>/h air / 3000 l/m water
- 9 m x 15 m x 7 m high test area

### DROPLET ANALYSIS

Frustrated by the limited capabilities of laser-based instruments, BETE developed the Model 700 Video Particle Analyzer. This flexible system allows BETE to

characterize the difficult sprays containing significant numbers of large and non-spherical drops often encountered in industrial applications. The Model 700 is a video-imaging system combining a CCD video camera, microscope lens, fast strobed xenon light source, and image processing hardware and software.

### PATTERN DISTRIBUTION ANALYSIS

The BETE Patternator is a unique digital video system for accurately analyzing the volumetric distribution of liquid emitted from a nozzle. The system uses a standard tube patternator combined with BETE's custom shape recognition and timing software. From this digitized information, spray density and effective spray angles are calculated.

Because data collection and analyses are handled by computer, the device is very well-suited for handling the large amount of data required for nozzle development and assessment programs.

Consistently and accurately selecting appropriate sampling positions is extremely important when performing drop size analysis. The challenge lies in sampling the spray in such a way that the number and locations of the individual tests chosen present a reasonable representation of the entire spray. Recognizing this, BETE has integrated the patternator with the Model 700 analyzer on a calibrated X-Y-Z positioner and developed a number of sampling protocols for droplet size analysis. These protocols ensure that the reported drop size distributions most accurately reflect the overall

spray performance, thus allowing a high degree of repeatability and confidence.

### COMPUTER MODELING AND SIMULATION

There are instances when duplicating the operating environment in the spray lab is impossible. When the nozzle is to be used in a high-temperature or pressure environment or sprayed in a high velocity gas stream, BETE Applications Engineers use computer modeling and simulation software developed in-house to assist in specifying the proper nozzle.

Spray-modeling has also been used to predict spray drift from cooling ponds and dust suppression systems and estimating evaporation rates from disposal ponds.

Working with engineering companies and consulting groups, BETE Engineering taps this modeling and simulation technology to offer customized spray nozzle solutions to some of the most vexing problems facing industry today.

### INDUSTRY COOPERATIVE DEVELOPMENT PROGRAMS

BETE has worked closely with major industries in research and development programs addressing personnel safety and environmental protection issues.

BETE has provided technical expertise, computer simulation, testing, and nozzle prototypes in a variety of projects, including:

- fire control aboard offshore drilling platforms
- toxic gas control
- oil spill cleanup
- reducing CFC use in the semiconductor industry



# Spray Coverage

## SPRAY ANGLE TERMS

Four terms are commonly used to describe spray coverage:

### Spray Angle:

**(A)** The included angle of the spray as measured close to the nozzle orifice. Since the droplets are immediately acted upon by external forces (gravity and moving gases, for example), this measurement is useful only for determining spray coverage close to the nozzle. The spray angles listed for nozzles in this catalog are angles at the nozzle, measured at the nozzle's design pressure.

### Actual Spray Coverage:

**(B)** The actual coverage at a specified distance **(D)** from the nozzle.

### Effective Spray Angle:

**(C)** The angle calculated from the actual coverage **(B)** at a distance **(D)**.

### Theoretical Spray Coverage:

**(E)** The coverage at distance **(D)** if the spray moved in a straight line.

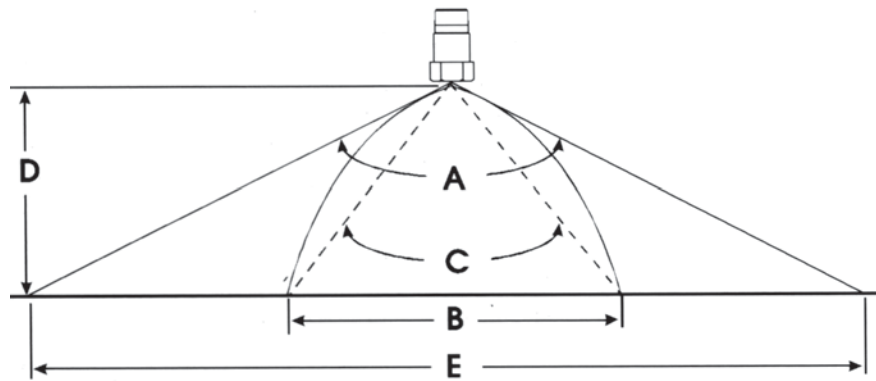

## THEORETICAL SPRAY COVERAGE (E) IN MILLIMETERS

Included Spray Angle (A)	Distance From Nozzle Orifice (D) (mm)										
	50	75	100	150	200	300	400	600	800	1000	
10°	9	13	17	26	35	52	70	105	140	175	
20°	18	26	35	53	71	106	141	212	282	353	
30°	27	40	54	80	107	161	214	322	429	536	
40°	36	55	73	109	146	218	291	437	582	728	
50°	47	70	93	140	187	280	373	560	746	933	
60°	58	87	115	173	231	346	462	693	924	1155	
70°	70	105	140	210	280	420	560	840	1120	1400	
80°	84	126	168	252	336	503	671	1007	1343	1678	
90°	100	150	200	300	400	600	800	1200	1600	2000	
100°	119	179	238	358	477	715	953	1430	1907	2384	
110°	143	214	286	428	571	857	1143	1714	2285		
120°	173	260	346	520	693	1039	1386	2078			
130°	214	322	429	643	858	1287	1716				
140°	275	412	549	824	1099	1648	2198				
150°	373	560	746	1120	1493	2239					
170°	1143	1715	2286								

**NOTE:** Data shown is theoretical and does not take into consideration the effects of gravity, gas flow, or high pressure operation.

## EXAMPLES:

**Problem:** To achieve a 200mm diameter spray coverage from a nozzle mounted 150mm from the target, what spray angle would be required?

**Solution:** 70° Spray Angle

**Problem:** How far from the target should a nozzle with a 110° spray angle be mounted in order to achieve a 550mm diameter spray?

**Solution:** Approximately 200mm. (Actual coverage will be less than theoretical coverage listed in the table.)

**NOTE:** For applications where coverage is critical, contact BETE Applications Engineering using the Applications Intake form on page 128.

# Water Flow Data

## Flow of Water Through Schedule 40 Steel Pipe

Discharge l/min	Pressure Drop per 100 meters and Velocity in Schedule 40 Pipe for Water at 15° C															
	Velocity m/sec	Press. Drop bar	Velocity m/sec	Press. Drop bar	Velocity m/sec	Press. Drop bar	Velocity m/sec	Press. Drop bar	Velocity m/sec	Press. Drop bar	Velocity m/sec	Press. Drop bar	Velocity m/sec	Press. Drop bar	Velocity m/sec	Press. Drop bar
	<b>1/8"</b>		<b>1/4"</b>		<b>3/8"</b>		<b>1/2"</b>		<b>3/4"</b>		<b>1"</b>					
1	0.459	0.726	0.251	0.17												
2	0.918	2.59	0.501	0.60	0.272	0.136	0.170	0.044								
3	1.38	5.59	0.752	1.22	0.407	0.29	0.255	0.091	0.144	0.023						
4	1.84	9.57	1.00	2.09	0.543	0.48	0.340	0.151	0.192	0.038	0.120	0.012				
5	2.29	14.45	1.25	3.18	0.679	0.70	0.425	0.223	0.241	0.057	0.150	0.017				
6	2.75	20.29	1.50	4.46	0.815	0.98	0.510	0.309	0.289	0.077	0.180	0.024	<b>1 1/4"</b>		<b>1 1/2"</b>	
8	3.67	35.16	2.01	7.36	1.09	1.69	0.680	0.524	0.385	0.129	0.240	0.041	0.138	0.011		
10			2.51	11.81	1.36	2.52	0.850	0.798	0.481	0.193	0.300	0.061	0.172	0.015	0.127	0.008
15			3.76	25.67	2.04	5.37	1.28	1.69	0.722	0.403	0.450	0.124	0.258	0.032	0.190	0.015
20			2.72	9.24	2.72	9.24	1.70	2.84	0.962	0.683	0.600	0.210	0.344	0.054	0.254	0.026
30	<b>2"</b>		<b>2 1/2"</b>													
40	0.231	0.016					2.55	6.17	1.44	1.45	0.90	0.442	0.517	0.114	0.380	0.053
50	0.308	0.027	0.216	0.010			3.4	10.72	1.92	2.50	1.20	0.758	0.689	0.193	0.507	0.091
60	0.385	0.039	0.270	0.017					2.41	3.83	1.50	1.14	0.861	0.290	0.634	0.135
70	0.462	0.055	0.324	0.023					2.89	5.41	1.80	1.61	1.03	0.400	0.761	0.187
80	0.539	0.098	0.378	0.031	<b>3"</b>				3.37	7.27	2.10	2.15	1.21	0.541	0.888	0.248
90	0.616	0.092	0.432	0.039	0.280	0.014	<b>3 1/2"</b>		3.85	9.27	2.40	2.76	1.38	0.690	1.01	0.315
100	0.693	0.115	0.486	0.048	0.315	0.017	0.235	0.008			2.70	3.47	1.55	0.862	1.14	0.397
150	0.770	0.141	0.540	0.059	0.350	0.020	0.261	0.010			3.00	4.25	1.72	1.05	1.27	0.488
200	1.15	0.295	0.810	0.125	0.524	0.042	0.392	0.021	0.304	0.011	4.50	9.30	2.58	2.26	1.90	1.03
250	1.54	0.512	1.08	0.212	0.699	0.072	0.523	0.036	0.405	0.019			3.44	3.91	2.54	1.81
300	1.92	0.773	1.35	0.322	0.874	0.108	0.653	0.053	0.507	0.028	<b>5"</b>				3.17	2.74
350	2.31	1.10	1.62	0.449	1.05	0.152	0.784	0.074	0.608	0.040	0.387	0.014	<b>6"</b>		3.80	3.82
400	2.69	1.47	1.89	0.606	1.22	0.203	0.915	0.099	0.710	0.053	0.452	0.018			4.44	5.18
450	3.08	1.92	2.16	0.780	1.40	0.264	1.05	0.128	0.811	0.068	0.516	0.023	0.357	0.009	5.07	6.69
500	3.46	2.39	2.43	0.979	1.57	0.329	1.18	0.161	0.912	0.084	0.581	0.028	0.402	0.012	5.71	8.45
550	3.85	2.95	2.70	1.20	1.75	0.403	1.31	0.196	1.01	0.101	0.646	0.034	0.447	0.014		
600	4.23	3.55	2.97	1.44	1.92	0.479	1.44	0.232	1.11	0.122	0.710	0.041	0.491	0.016		
650	4.62	4.20	3.24	1.69	2.10	0.566	1.57	0.273	1.22	0.146	0.775	0.047	0.536	0.019		
700	5.00	6.88	3.51	1.97	2.27	0.658	1.70	0.319	1.32	0.169	0.839	0.055	0.581	0.022		
750	5.39	5.63	3.78	2.28	2.45	0.759	1.83	0.368	1.42	0.194	0.904	0.063	0.625	0.025		
800	5.77	6.44	4.05	2.60	2.62	0.863	1.96	0.420	1.52	0.218	0.968	0.072	0.670	0.029		
850			4.32	2.95	2.80	0.977	2.09	0.473	1.62	0.246	1.03	0.081	0.715	0.032		
900			4.59	3.31	2.97	1.09	2.22	0.528	1.72	0.277	1.10	0.091	0.760	0.036	0.439	0.009
950					3.15	1.22	2.35	0.585	1.82	0.308	1.16	0.101	0.804	0.041	0.465	0.010
1000					3.32	1.35	2.48	0.649	1.93	0.342	1.23	0.111	0.849	0.045	0.491	0.012
1100					3.50	1.50	2.61	0.714	2.03	0.377	1.29	0.122	0.894	0.049	0.516	0.013
1200					3.85	1.75	2.87	0.860	2.23	0.452	1.42	0.147	0.983	0.059	0.568	0.015
1300					4.20	2.14	3.14	1.02	2.43	0.534	1.55	0.172	1.07	0.069	0.620	0.018
1400							3.40	1.19	2.64	0.627	1.68	0.200	1.16	0.080	0.671	0.021
							3.66	1.37	2.84	0.722	1.81	0.232	1.25	0.091	0.723	0.024

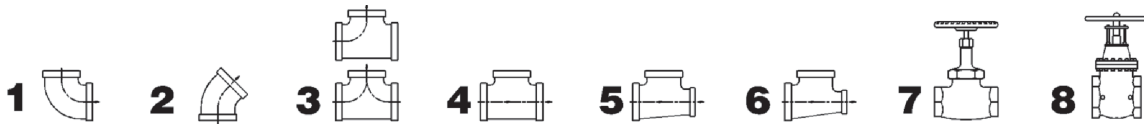

### Valve & Fitting Losses Expressed in Equivalent Meters of Pipe

Pipe Fitting or Valve	Nominal Pipe or Tube Size (mm)												
	10	15	20	25	32	40	50	65	80	90	100	125	150
1 90° Standard Elbow	0.43	0.49	0.61	0.79	1.01	1.22	1.52	1.83	2.29	2.74	3.05	3.96	4.88
2 45° Standard Elbow	0.21	0.24	0.27	0.40	0.52	0.64	0.79	0.98	1.22	1.43	1.58	1.98	2.41
3 Flow-Through Branch Tee	0.82	0.91	1.22	1.52	2.13	2.44	3.05	3.66	4.57	5.49	6.40	7.62	9.14
4 Straight Through Flow Tee - No Reduction	0.27	0.30	0.43	0.52	0.70	0.79	1.01	1.25	1.52	1.80	2.04	2.50	3.05
5 Straight Through Flow Tee - Reduced 1/4	0.37	0.43	0.58	0.70	0.94	1.13	1.43	1.71	2.13	2.44	2.74	3.66	4.27
6 Straight Through Flow Tee - Reduced 1/8	0.43	0.49	0.61	0.79	1.01	1.22	1.52	1.83	2.29	2.74	3.05	3.96	4.88
7 Globe Valve - Fully opened	5.18	5.49	6.71	8.84	11.6	13.1	16.8	21.0	25.6	30.5	36.6	42.7	51.8
8 Gate Valve - Fully opened	0.18	0.21	0.27	0.30	0.46	0.55	0.70	0.85	0.98	1.22	1.37	1.83	2.13

# Notes

## FLOW OF AIR THROUGH SCHEDULE 40 STEEL PIPE

Free Air m <sup>3</sup> /min at 15°C & 1.013 bar abs	Compressed Air m <sup>3</sup> /min at 15°C at 7 bar gauge	Pressure Drop per 100m of Schedule 40 Pipe For Air For 15°C and 7 bar gauge pressure									
		<b>1/8"</b>	<b>1/4"</b>	<b>3/8"</b>	<b>1/2"</b>						
0.03	0.0038	0.093	0.021	0.0045							
0.06	0.0076	0.337	0.072	0.016	0.0051						
0.09	0.0114	0.719	0.154	0.033	0.011						
0.12	0.0152	1.278	0.267	0.058	0.018	<b>3/4"</b>					
0.15	0.0190	1.942	0.405	0.087	0.027	0.0067					
							<b>1"</b>				
0.2	0.0253	3.357	0.698	0.146	0.047	0.011	0.0035				
0.3	0.0379	7.554	1.57	0.319	0.099	0.024	0.0073				
0.4	0.0506		2.71	0.548	0.170	0.041	0.012	<b>1 1/4"</b>			
0.5	0.0632		4.10	0.842	0.257	0.062	0.018				
0.6	0.0759		5.90	1.19	0.370	0.088	0.026	0.0066	<b>1 1/2"</b>		
0.7	0.0885		8.03	1.62	0.494	0.117	0.035	0.0086	0.0041		
0.8	0.101			2.12	0.634	0.150	0.044	0.011	0.0053		
0.9	0.114			2.64	0.803	0.187	0.055	0.014	0.0065		
1.0	0.126			3.26	0.991	0.231	0.067	0.017	0.0079		
1.25	0.158			4.99	1.55	0.353	0.102	0.026	0.012		<b>2"</b>
1.5	0.190			7.20	2.19	0.499	0.147	0.036	0.017	0.0048	
1.75	0.221	<b>2 1/2"</b>		9.79	2.98	0.679	0.196	0.047	0.022	0.0064	
2.0	0.253				3.82	0.871	0.257	0.062	0.029	0.0082	
2.25	0.284	0.0042			4.84	1.10	0.325	0.076	0.036	0.010	
2.5	0.316	0.0051			5.97	1.36	0.393	0.094	0.045	0.012	

# Pipe Dimensions & Weights

Nominal Pipe Size	OD	Schedule	Wall Thickness	ID	Weight
<b>1/8</b> [6]	<b>0.405</b> [10.3]	10 10S	1.24	7.8	0.28
		STD 40 40S	1.73	6.8	0.36
		XS 80 80S	2.41	5.5	0.47
<b>1/4</b> [8]	<b>0.540</b> [13.7]	10 10S	1.65	10.4	0.49
		STD 40 40S	2.24	9.3	0.63
		XS 80 80S	3.02	7.7	0.80
<b>3/8</b> [10]	<b>0.675</b> [17.1]	10 10S	1.65	13.8	0.63
		STD 40 40S	2.31	12.5	0.85
		XS 80 80S	3.20	10.7	1.10
<b>1/2</b> [15]	<b>0.840</b> [21.3]	5 5S	1.65	18.0	0.80
		10 10S	2.11	17.1	1.00
		STD 40 40S	2.77	15.8	1.27
		XS 80 80S	3.73	13.9	1.62
		160	4.78	11.8	1.95
<b>3/4</b> [20]	<b>1.050</b> [26.7]	5 5S	1.65	23.4	1.02
		10 10S	2.11	22.5	1.28
		STD 40 40S	2.87	20.9	1.68
		XS 80 80S	3.91	18.9	2.19
		160	5.56	15.5	2.89
<b>1</b> [25]	<b>1.315</b> [33.4]	5 5S	1.65	30.1	1.29
		10 10S	2.77	27.9	2.09
		STD 40 40S	3.38	26.6	2.50
		XS 80 80S	4.55	24.3	3.23
		160	6.35	20.7	4.23
<b>1-1/4</b> [32]	<b>1.660</b> [42.2]	5 5S	1.65	38.9	1.65
		10 10S	2.77	36.6	2.69
		STD 40 40S	3.56	35.1	3.38
		XS 80 80S	4.85	32.5	4.46
		160	6.35	29.5	5.60
<b>1-1/2</b> [40]	<b>1.900</b> [48.3]	5 5S	1.65	45.0	1.90
		10 10S	2.77	42.7	3.10
		STD 40 40S	3.68	40.9	4.04
		XS 80 80S	5.08	38.1	5.40
		160	7.14	34.0	7.23
<b>2</b> [50]	<b>2.375</b> [60.3]	5 5S	1.65	57.0	2.39
		10 10S	2.77	54.8	3.93
		STD 40 40S	3.91	52.5	5.44
		XS 80 80S	5.54	49.3	7.47
		160	8.74	42.9	11.10
<b>3</b> [80]	<b>3.500</b> [88.9]	5 5S	2.11	84.7	4.51
		10 10S	3.05	82.8	6.45
		STD 40 40S	5.49	77.9	11.27
		XS 80 80S	7.62	73.7	15.26
		160	11.13	66.7	21.32
<b>3-1/2</b> [90]	<b>4.000</b> [101.6]	5 5S	2.11	97.4	5.17
		10 10S	3.05	95.5	7.40
		STD 40 40S	5.74	90.1	13.56
		XS 80 80S	8.08	85.5	18.61
		160	16.15	69.3	34.00

Nominal Pipe Size	OD	Schedule	Wall Thickness	ID	Weight
<b>4</b> [100]	<b>4.500</b> [114.3]	5 5S	2.11	110.1	5.83
		10 10S	3.05	108.2	8.35
		STD 40 40S	6.02	102.3	16.06
		XS 80 80S	8.56	97.2	22.30
		120	11.13	92.1	28.28
<b>6</b> [150]	<b>6.625</b> [168.3]	160	13.49	87.3	33.50
		XX	17.12	80.1	40.99
		5 5S	2.77	162.7	11.29
		10 10S	3.40	161.5	13.83
		STD 40 40S	7.11	154.1	28.24
<b>8</b> [200]	<b>8.625</b> [219.1]	XS 80 80S	10.97	146.3	42.52
		120	14.27	139.7	54.16
		160	18.26	131.8	67.49
		XX	21.95	124.4	79.11
		5 5S	2.77	213.5	14.75
<b>10</b> [250]	<b>10.750</b> [273.1]	10 10S	3.76	211.6	19.94
		20	6.35	206.4	33.28
		30	7.04	205.0	36.75
		STD 40 40S	8.18	202.7	42.49
		60	10.31	198.5	53.04
		XS 80 80S	12.70	193.7	64.57
		100	15.09	188.9	75.82
		120	18.26	182.6	90.35
		140	20.62	177.8	100.83
		160	22.23	174.6	107.78
<b>12</b> [300]	<b>12.750</b> [323.9]	XX	23.01	173.1	111.15
		5 5S	3.40	266.2	22.61
		10 10S	4.19	264.7	27.76
		20	6.35	260.4	41.72
		30	7.80	257.5	50.96
		STD 40 40S	9.27	254.5	60.25
		XS 60 80S	12.70	247.7	81.46
		80	15.09	242.9	95.88
		100	18.26	236.5	114.63
		120	21.44	230.2	132.88
<b>12</b> [300]	<b>12.750</b> [323.9]	140	25.40	222.3	154.97
		160	28.58	215.9	172.10
		5 5S	3.96	315.9	31.23
		10 10S	4.57	314.7	35.96
		20	6.35	311.2	49.67
		30	8.38	307.1	65.14
		STD 40 40S	9.53	304.8	73.76
		40	10.31	303.2	79.65
		XS 80 80S	12.70	298.5	97.35
		60	14.27	295.3	108.87
<b>12</b> [300]	<b>12.750</b> [323.9]	80	17.48	288.9	131.90
		100	21.44	281.0	159.71
		120	25.40	273.1	186.75
		140	28.58	266.7	207.86
		160	33.32	257.2	238.51



# BETE Fog Nozzle, Inc.

## Application Information Sheet

FAX: 413 772-6729  
email: appeng@bete.com

Name: \_\_\_\_\_ Company: \_\_\_\_\_

Telephone: \_\_\_\_\_ Company Address: \_\_\_\_\_

FAX: \_\_\_\_\_ email: \_\_\_\_\_ BETE Cust. # \_\_\_\_\_

Sketch a simple representation of the application below:

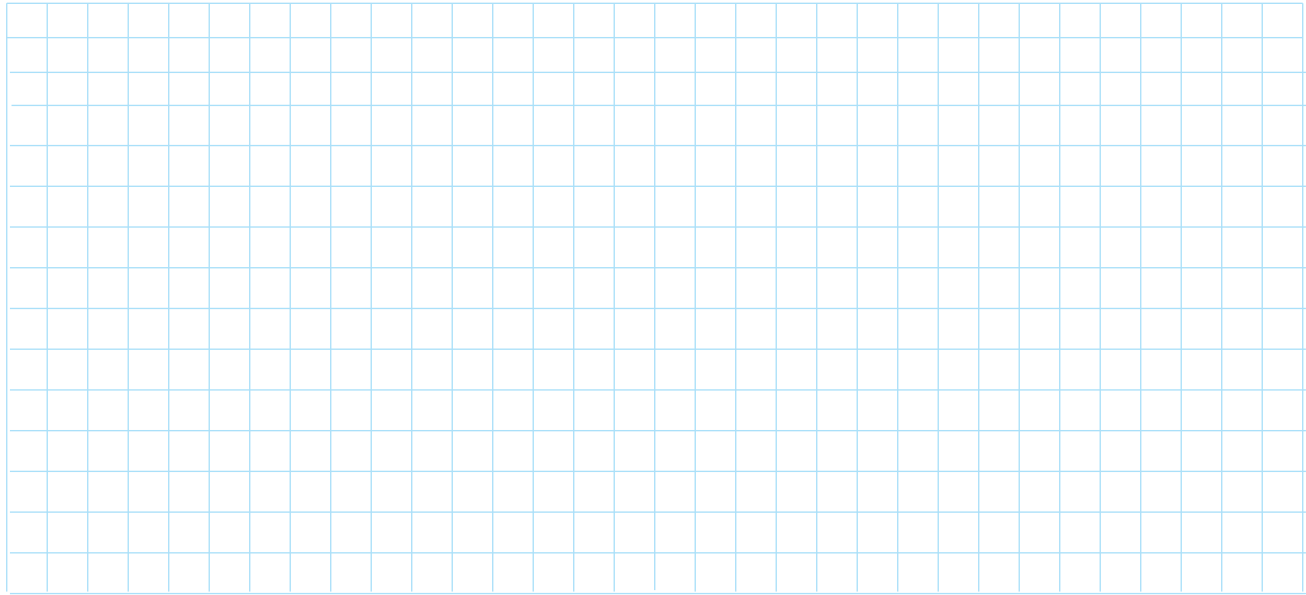

• What are you trying to accomplish with the spray?

• What is the available pressure?

• What is the desired material of construction?

• What is the flow rate?

• What is the piping material?

• What is the desired flow rate?

• What are the size and connection types desired?

• What liquid is being sprayed?

• What is the distance from the nozzle to the target?

• What is the desired spray angle or coverage?

• What are the environmental conditions surrounding the nozzle?

# Conversions & Equations

**Q = Flow rate**

**P = Pressure SG= Specific Gravity**

$$Q = K (P)^x$$

$$\left(\frac{Q_2}{Q_1}\right) = \sqrt{\frac{SG_1}{SG_2}}$$

$$P = \left(\frac{Q}{K}\right)^{1/x}$$

*Vessel with internal pressure:*

$$\left(\frac{Q_2}{Q_1}\right) = \left(\frac{P_2}{P_1}\right)^x$$

$$l/min = K (P_{inlet} - P_{Vessel})^x$$

**Dropsizes**

**System Design**

$$\left(\frac{D_2}{D_1}\right) = \left(\frac{P_2}{P_1}\right)^{0.3}$$

$$P_{Pump} = P_{Nozzle} + P_{Pipe Losses} + \frac{\rho h}{100000}$$

Nozzle Series	Exponent x	Nozzle Series	Exponent x
BJ	0.50	PJ	0.50
CW	0.47	PSR	0.50
FF	0.50	SC	0.47
IS	0.50	SPN	0.50
L	0.50	ST	0.50
LP	0.50	STXP	0.50
MaxiPass	0.47	TC	0.46
MPL	0.43	TD/TDL	0.50
MicroWhirl	0.50	TF	0.50
N	0.50	TFXP	0.50
NC	0.47	TH, THW	0.50
NCJ	0.47	TW	0.50
NCK	0.47	WL	0.47
NCS	0.47	WT	0.50
NF	0.50	WTX	0.50
P	0.50	WTZ	0.50

Conversion Data		
MULTIPLY	BY	TO OBTAIN
atmospheres	1.013	bar
atmospheres	33.931	feet of water
atmospheres	1.0332	kg/cm <sup>2</sup>
atmospheres	101.3	kiloPascals (kPa)
atmospheres	14.696	psi
bar	100	kPa
bar	14.5	psi
barrels (oil)	42	gallons
centimeters	0.3937	inches
centiStokes	Sp. gravity	centiPoise
cm <sup>3</sup>	0.061	in <sup>3</sup>
cm <sup>3</sup>	0.000264	gallons
cm <sup>3</sup>	0.001	liters
ft <sup>3</sup>	1728	inches
ft <sup>3</sup>	0.02832	m <sup>3</sup>
ft <sup>3</sup>	7.48	gallons
ft <sup>3</sup>	28.32	liters
ft <sup>3</sup> (water)	62.43	pounds (water)
in <sup>3</sup>	16.39	cm <sup>3</sup>
in <sup>3</sup>	0.00433	gallons
in <sup>3</sup>	0.164	liters
m <sup>3</sup>	35.31	ft <sup>3</sup>
m <sup>3</sup>	61.024	in <sup>3</sup>
m <sup>3</sup>	264.2	gallons
m <sup>3</sup>	1000	liters
degree (angle)	60	minutes
degree (Celsius)	(°C x 1.8) +32	degree (Fahrenheit)
degree (Fahrenheit)	(°F-32) x 5/9	degree (Celsius)
feet	0.3048	meters
feet/sec	30.48	centimeters/sec

Conversion Data		
MULTIPLY	BY	TO OBTAIN
feet/sec	18.29	meters/min
feet of water	0.0295	atmospheres
feet of water	0.884	inches of mercury
feet of water	0.433	psi
gallons	3785	cm <sup>3</sup>
gallons	0.1337	ft <sup>3</sup>
gallons	0.83267	imperial gallons
gallons	3.785	liters
gallons/min	0.06309	liters/sec
imperial gallons	1.2	gallons
horsepower	1.014	horsepower (metric)
horsepower	33,000	foot pounds/min
horsepower	746	Watts
inches	2.54	centimeters
kg/cm <sup>2</sup>	14.22	psi
kiloWatts	1.340	horsepower
liters	1000	cm <sup>3</sup>
liters	0.264	gallons
liters	0.22	imperial gallons
liters	33.8	ounces (fluid)
meters	3.281	feet
microns (µm)	0.0394	thousandth of an inch
miles/hr	44.7	centimeters/sec
miles/hr	1.467	feet/sec
millimeters	0.0394	inches
psi	0.068	atmospheres
psi	0.06895	bar
psi	2.307	feet of water
psi	0.0703	kg/cm <sup>2</sup>
psi	6.895	kPa

## Terms and Conditions.

Prices quoted are FOB, Greenfield, MA. Terms are Net 30 days for approved accounts. Minimum order is \$50.00 net. A restocking charge of 30% will apply for standard product accepted for return up to one year from the date of purchase. BETE FOG NOZZLE reserves the right to charge interest on past-due accounts. No goods may be returned without prior authorization. Non-Standard items are not subject to return.

BETE FOG NOZZLE reserves the right to make changes in specifications or design at any time without notice. Illustrations shown in this catalog are for information only.

**Warranty**—all goods are warranted for good workmanship in accordance with industry standard and will perform in accordance with the products' specification.

**Limitation of Liability**—BETE's liability shall be limited to the value of the product billed arising from a purchase order.



THE  
**SPRAY NOZZLE**  
PEOPLE

01273 400092 | [info@spray-nozzle.co.uk](mailto:info@spray-nozzle.co.uk) | [www.spray-nozzle.co.uk](http://www.spray-nozzle.co.uk)

BETE Fog Nozzle, Inc.

50 Greenfield Street, Greenfield | MA 01301 USA

413-772-0846 | [www.BETE.com](http://www.BETE.com) | [sales@BETE.com](mailto:sales@BETE.com)



Spray  
Nozzles



Spray  
Fabrications



Spray  
Systems



Applications  
Engineering



Spray  
Research

